

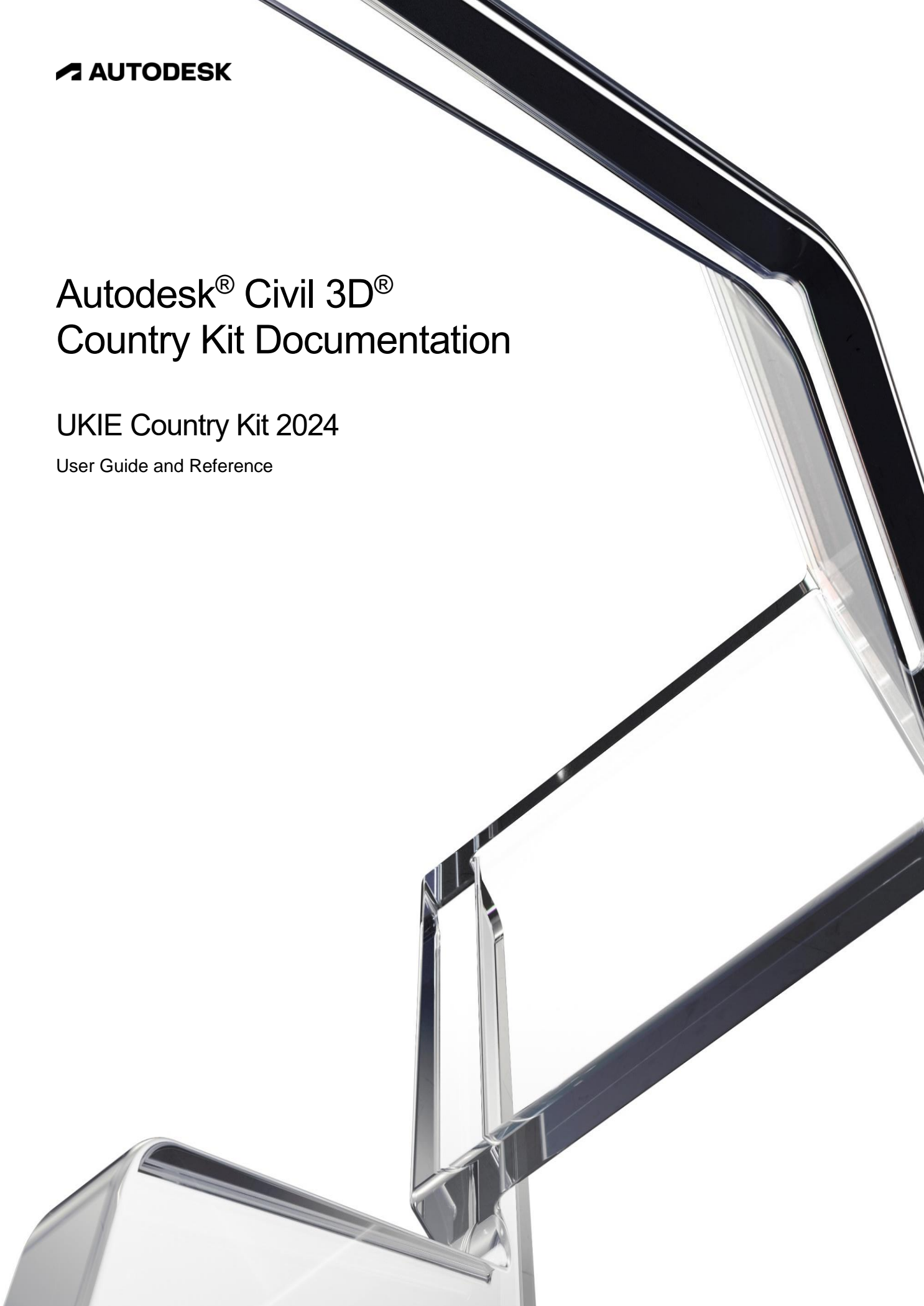

Autodesk® Civil 3D® Country Kit Documentation

UKIE Country Kit 2024

User Guide and Reference



Contents

1.0	Overview	7
1.1	Version History	7
1.2	UKIE Country Kit for Civil 3D 2024.....	7
1.3	Downloading.....	7
1.4	Instructional Videos.....	7
1.4.1	New User Introduction to the UKIE Country Kit for Autodesk Civil 3D.	7
1.4.2	New features added to the UKIE Country Kit for Autodesk Civil 3D 2021.....	8
1.4.3	New features added to the UKIE Country Kit for Autodesk Civil 3D 2024.....	8
1.5	How to View the Reference Documentation.....	8
1.6	Using the Country Kit.....	8
1.7	Overview.....	9
1.8	The ‘UKIE’ Tool Palette.....	10
1.9	The ‘UKIE Design’ Tool Palette.....	11
1.9.1	Typical Road Subassemblies.....	11
1.9.2	British Standard Subassemblies	14
1.9.3	Other Road Subassemblies	15
1.9.4	Rehab Road Subassemblies.....	16
1.9.5	Typical Section Sub-Assemblies	16
1.9.6	Hedge Mark Point	17
1.9.7	Dynamic Turning Heads	17
1.9.8	Legacy Sub-Assemblies	18
1.9.9	Design Standards	18
1.10	The ‘UKIE Junction Assemblies’ Tool Palette.....	19
1.10.1	Junction Assemblies (2023).....	20
1.10.2	Basic Estate Road Junction Assemblies (Legacy)	23
1.10.3	Junction Assemblies (Legacy)	24
1.10.4	Using the Junction Design Wizard	25
1.11	MicroDrainage	26
1.12	DMRB Road Sections	27
1.13	NRA Road Sections.....	28
1.14	Legacy UKIE Subassemblies.....	29

1.14.1	Typical Road Subassemblies (Legacy) and British Standards (Legacy).....	29
1.14.2	Older Legacy Subassemblies	29
2.0	Drawing Template	30
2.1	Overview.....	30
2.1.1	Default UKIE Template	30
2.1.2	GG-184 Template	30
2.2	Uniclass 2015 Layer Structure	31
2.2.1	Overview.....	31
2.2.2	Civil 3D Object Defaults	31
2.2.3	Layer Filters	32
2.2.4	Using the Layering System	32
2.2.5	Using Layer Modifiers	32
2.2.6	Purging layers.....	32
2.3	Multi-Purpose Styles	33
2.3.1	Marker Styles.....	33
2.3.2	Feature Line Styles	33
2.3.3	Slope Pattern Styles	34
2.3.4	Projection Styles	34
2.3.5	Code Set Styles	34
2.3.6	Link Styles	36
2.3.7	Shape Styles.....	37
2.3.8	General Label Styles.....	38
2.4	Point Settings.....	39
2.4.1	Point Styles and Point Label Styles.....	39
2.4.2	Point File Formats.....	40
2.4.3	Descriptive Key Sets.....	40
2.4.4	Point Table Styles	41
2.5	Surface Settings	42
2.5.1	Surface Styles.....	42
2.5.2	Surface Label Styles	43
2.5.3	Surface Table Styles.....	43
2.6	Parcel (Plot) Settings	44

2.6.1	Parcel Styles.....	44
2.6.2	Parcel Label Styles	44
2.6.3	Parcel Table Styles.....	44
2.7	Grading.....	45
2.7.1	Grading Styles	45
2.7.2	Grading Criteria Sets	45
2.8	Alignments.....	46
2.8.1	Alignment Styles	46
2.8.2	Alignment Label Sets	46
2.8.3	Additional Alignment Labels.....	47
2.8.4	Alignment Tables	47
2.9	Profiles and Profile Views	48
2.9.1	Profile Styles.....	48
2.9.2	Profile Label Sets.....	48
2.9.3	Additional Profile Labels	49
2.9.4	Profile View Styles	49
2.9.5	Band Sets.....	49
2.9.6	Additional Band Styles	51
2.10	Sample Line Styles	51
2.10.1	Sample Line Styles and Sample Line Label Styles	51
2.11	Sections and Section Views.....	52
2.11.1	Section Styles.....	52
2.11.2	Section Label Sets.....	53
2.11.3	Additional Section Labels.....	54
2.11.4	Section View Styles	54
2.11.5	Section View Band Sets.....	54
2.11.6	Additional Band Styles	56
3.0	Toolbox Utilities	57
3.1	Civil Model Reports (Reports)	57
3.1.1	Feature Lines.....	58
3.1.2	Alignments.....	58
3.1.3	Profiles.....	60

3.1.4	Corridor.....	63
3.1.5	Points	66
3.2	Additional Tools (Utilities).....	67
3.2.1	2D to 3D Contours Conversion	67
3.2.2	Surface Analysis – Import from a File	68
3.2.3	Surface Analysis – Export to File	68
3.2.4	Surface Analysis – Copy Analysis to Another Surface	68
3.2.5	Drawing Frame Grid to Viewport	69
3.2.6	Convert Blocks to COGO Points	70
3.2.7	Legacy Export Construction	70
3.2.8	Export Feature Line Chainage with XYZ	70
3.2.9	Export for Construction	71
3.2.10	Layer Update Tool (previously the ‘Layer Conversion Tool’)	72
3.2.11	Uniclass 2015 Layer Report.....	75
3.2.12	UKIE 2D Sign Block Generator	78
4.0	Pipe Networks	86
4.1	Overview.....	86
4.2	Network Catalogs.....	86
4.3	Pipe Network Setting	87
4.3.1	Parts Lists.....	87
4.4	Pipe Settings.....	88
4.4.1	Pipe Styles.....	88
4.4.2	Pipe Rule Sets	88
4.4.3	Pipe Label Styles	89
4.4.4	Pipe Table Styles	89
4.5	Structure Settings	90
4.5.1	Structure Styles	90
4.5.2	Structure Rule Sets.....	91
4.5.3	Structure Label Styles.....	92
4.5.4	Structure Table Styles.....	92
4.6	Band Sets	93
4.6.1	‘Pipe Network’ Band Set	93

4.7	Support for Sewers for Adoption (7 th Edition)	94
4.7.1	Overview.....	94
4.7.2	Catalog Selection.....	94
4.7.3	Parts Lists (SFAv7)	95
4.7.4	Structures (SFAv7)	96
4.7.5	Structure Designations (SFAv7).....	98
4.7.6	Pipes (SFAv7).....	100
4.7.7	Pipe Designations (SFAv7)	100
4.7.8	Pipe Styles (SFAv7).....	101
4.7.9	Structure Styles (SFAv7)	102
4.7.10	Pipe Rules Sets (SFAv7)	103

1.0 Overview

1.1 Version History

Versions of this document:

<i>Version</i>	<i>Date</i>	<i>Update Description</i>
1.0	10/06/2020	Prepared for Autodesk® Civil 3D® 2021
2.0	23/03/2021	Prepared for Autodesk® Civil 3D® 2022
3.0	18/01/2022	Added documentation for UKIE Pipes and Structures
3.1	28/03/2022	Updated for Autodesk® Civil 3D® 2023
4.0	02/05/2023	Updated for Autodesk® Civil 3D® 2024

1.2 UKIE Country Kit for Civil 3D 2024

The UKIE Country Kit for Civil 3D 2024 is a downloadable addition to Civil 3D 2024 which gives you additional functionality to get the most out of Civil 3D for the delivery of projects in the UK and Ireland.

Included in this country kit are additional:

- Subassemblies
- Drawing templates
- Toolbox utilities
- Pipe and Structure Catalogues
- Junction wizard sets
- Assembly sets.

1.3 Downloading

This country kit can be downloaded from the following web page:

[<Civil 3D Country Kits for United Kingdom & Ireland>](#)

1.4 Instructional Videos

1.4.1 New User Introduction to the UKIE Country Kit for Autodesk Civil 3D.

This video gives an overview of the extra content included in the UKIE Country Kit for Autodesk Civil 3D 2020. Whilst based upon 2020, this overview is aimed at individuals new to Autodesk Civil 3D and those who would like to examine how the UKIE Country Kit can enhance the Autodesk Civil 3D experience.

[Video: UKIE Overview of functionality UKIE 2020](#)

1.4.2 New features added to the UKIE Country Kit for Autodesk Civil 3D 2021

This video showcases the new features added to the UKIE Country Kit for Autodesk Civil 3D 2021. Whilst specifically authored for the 2021 kit, this video offers a suitable introduction to the 2023 Country Kit as changes between the two releases have been minimal. This video is aimed at individuals who are experienced with Autodesk Civil 3D and may have used previous versions of the UKIE Country Kit. It also has been authored to suggest best practices and to highlight changes and improvements.

[Video: UKIE What's new in 2021](#)

1.4.3 New features added to the UKIE Country Kit for Autodesk Civil 3D 2024

This video highlights the changes to the country kit that were introduced in the 2024 release. This video is aimed at individuals who are familiar with previous versions and just want to see the features added to, and improved in, the UKIE Country Kit for Autodesk Civil 3D 2024.

[Video: UKIE What's new in 2024](#)

1.5 How to View the Reference Documentation

To avoid doubling up on documentation that exists elsewhere, various reference links are included to locally installed files. The links provided will work only if you view this document in the same folder as the additional documentation. By default, all the UKIE documentation is installed in:

'%Documents%\UKIE Content Kit for Autodesk Civil 3D 2024 Documentation'

You may need to accept security messages if you open the linked .pdf files directly from within this document.

These reference links will only be available if you have installed the UKIE Country Kit for Civil 3D 2024 or download the full set of documentation.

1.6 Using the Country Kit

The UKIE Country Kit for Civil 3D 2024 is best launched using the new icon that will be created on your desktop.

This icon, 'Civil 3D 2024 UKIE', will give you access to all the features in the Country Kit.



Launching Civil 3D from any other icon will **NOT** necessarily give you all the tools outlined in this document.

If you cannot find this icon on your desktop, you may need to search for it in the Windows Search bar.



Tool Palettes

1.7 Overview

The Tool Palettes can be displayed in Civil 3D by pressing {Ctrl – 3} on the keyboard.

Seven additional tool palettes are installed for the UKIE Country Kit, and are arranged in the following order:

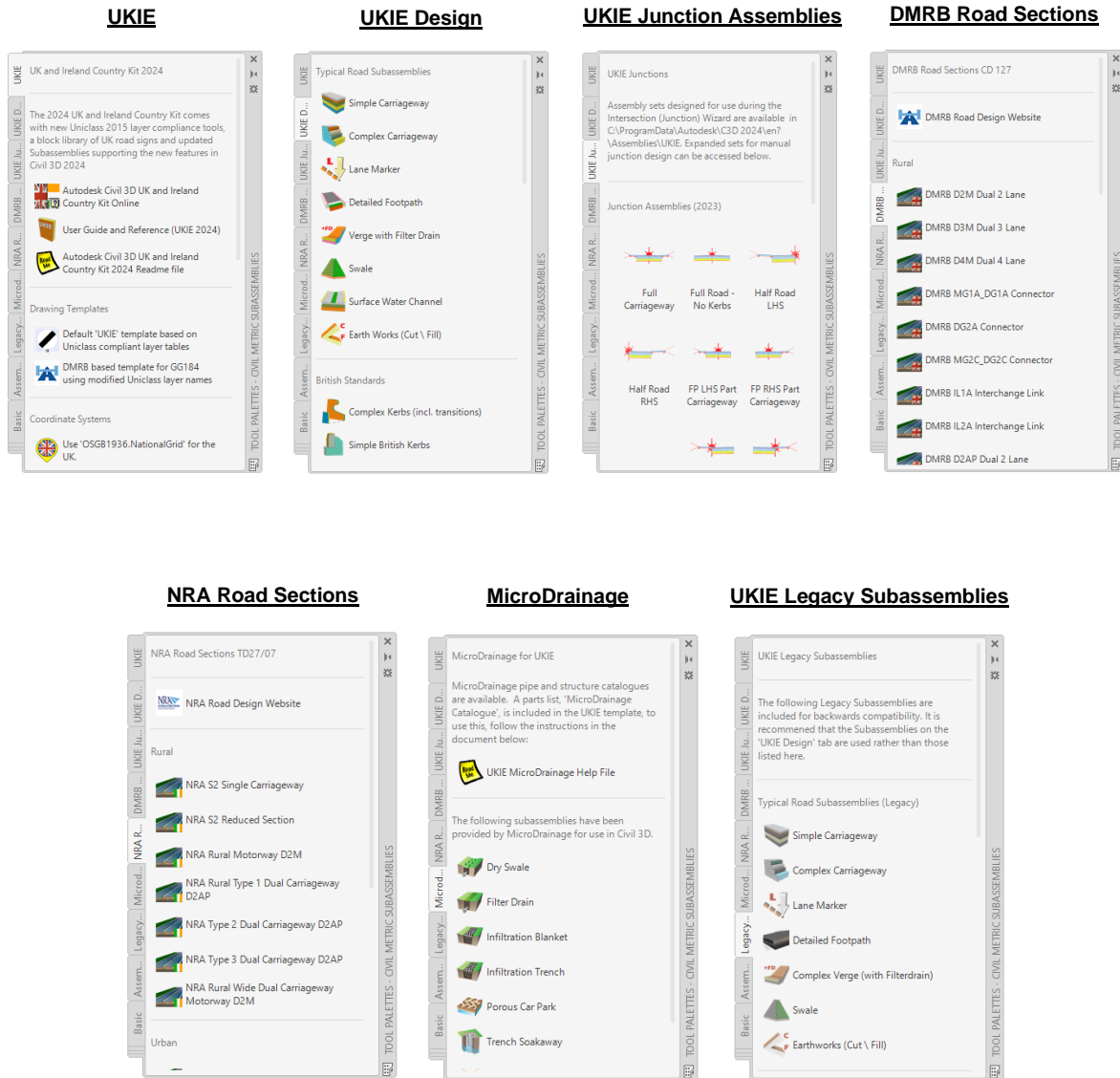

These tool palettes are grouped together in the 'Civil 3D Metric Sub Assemblies' palette group and mostly contain subassemblies, but also contain other icons outside the scope of assembly design. Each Tool Palette is documented in the sections that follow:

1.9 The 'UKIE Design' Tool Palette

This Tool Palette contains numerous subassemblies to aid assembly design.

In the majority of cases, the subassemblies in this tool pallet have been updated to reflect the changes to subassembly design introduced in Civil 3D 2024. The old subassemblies that they replace, along with other depreciated subassemblies, have been moved to the new tool palette 'UKIE – Legacy Subassemblies'.

1.9.1 Typical Road Subassemblies

A collection of subassemblies that compliment road design.

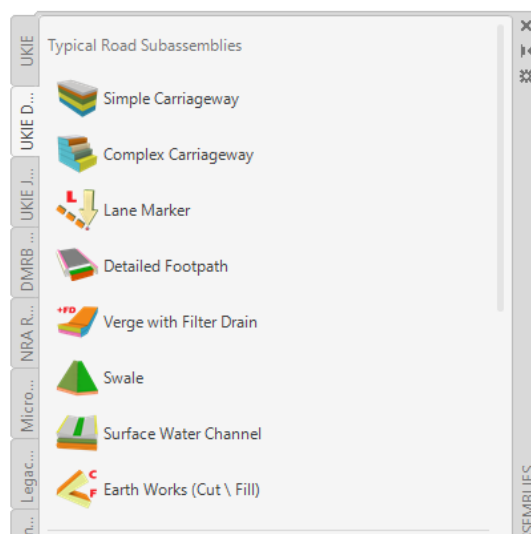

Simple Carriageway (UKIESimpleCarriageway - v2024)

This is a basic carriageway design that supports 'Superelevation'. Only the most basic of codes and simple property sets are available. This represents a simple sub-assembly that is easy to understand and work with and is therefore ideal for users beginning to use Civil 3D. It has the following characteristics:

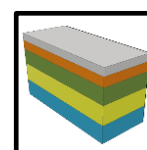

- Full control of each course (Surface, Binder etc.,)
- Basic edge of carriageway step slope control
- Only basic codes have been exposed
- Unneeded point codes have been hidden
- Superelevation is disabled by default
- Height and Width targeting for the channelline
- Crossfall is exportable to other subassemblies

[<Click here for detailed documentation>](#)

Complex Carriageway (UKIEComplexCarriageway - v2024)

For more flexibility in carriageway design, it is recommended that you use this subassembly in preference to the 'Simple Carriageway'. It has the following characteristics:

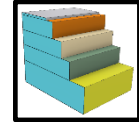

- Full control of each course (Surface, Binder etc.,)
- Edge of carriageway step slope control
- All point, link and shape codes are exposed
- Superelevation is enabled by default
- Height and Width targeting are supported for each edge of the lane
- A clearance envelope is available
- Basic widening option
- Crossfall is exportable to other subassemblies

[<Click here for detailed documentation>](#)

Lane Marker (UKIELaneMarker - v2024)

The 'Lane Marker' subassembly is designed to overlay a simple 'Lane' code onto a carriageway to prevent the need for multiply carriageway subassemblies. This has the advantage of creating a corridor with less overhead and simplifying targeting practices and material take off.

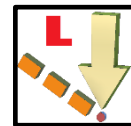

[<Click here for detailed documentation>](#)

Detailed Footpath (UKIEFootpath – v2024)

The UKIE Detailed Footpath was updated for the 2020 Civil 3D release. Changes include geometry fixes, and most of the link and point codes have been exposed to the properties sheet.

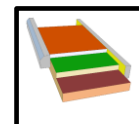

[<Click here for detailed documentation>](#)

Complex Verge with Filterdrain – (UKIEVergeFD - v2024)

The 'UKIEVergeFD' subassembly has the following characteristics:

- Default variant varies the slope dependent upon cut and fill
- Simple 'Basic' variant
- Separate slope values for basic, and both cut and fill conditions
- Filter-drain option
- Height and Width targeting supported at verge end
- All codes are exposed

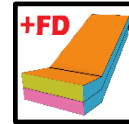

<[Click here for detailed documentation](#)>

Swale (UKIESwale - v2024)

The 'Swale' sub-assembly was updated for the 2020 Civil 3D Release.

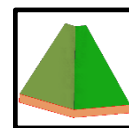

<[Click here for detailed documentation](#)>

Earthworks Cut\Fill (UKIEEarthworks - v2024)

The 'Earthworks' Subassembly has the following characteristics:

- Displays as a simple layout during assembly creation
- Different slope values for CUT and FILL conditions
- Two material layers
- Multiple intercept options (max 10)
- All codes are exposed



<[Click here for detailed documentation](#)>

1.9.2 British Standard Subassemblies

A collect of subassemblies to address standard British block designations.

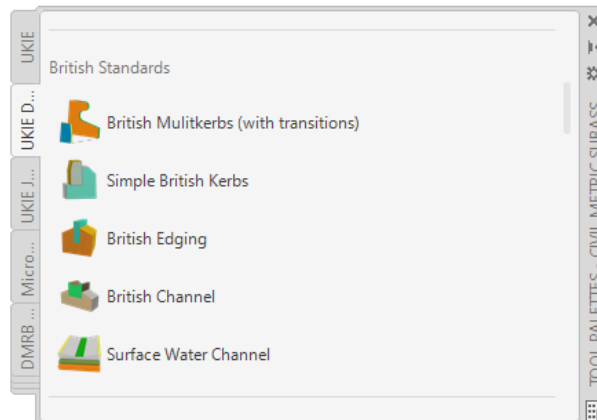

British Multikerbs with transitions (UKIEMultiKerbs – v2024)

The 'UKIEMultiKerbs' subassembly is provided to give flexible insertion of British Kerbs and has the following characteristics:



- Half Battered, Splayed, Bullnose, Trief and Kassel kerb types
- Custom variants of all designations
- With or without a concrete backing
- Insertion point at 'Back of Kerb' or 'Channelline'
- All point, link and shape codes are exposed
- Two transitions supported
- A ghosted transition line option

<[Click here for detailed documentation](#)>

Simple British Kerbs (UKIEBritishKerbs – v2024)

Whilst these British Kerbs have been superseded by the Multikerb variant, they remain current as they represent a simple lightweight alternative that does not support the overhead of transitioning. Changes introduced in UKIE 2020 included full control off the concrete backing, a 'custom' kerbtype option and a useful 'Waterline Offset' variable.

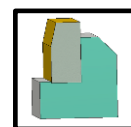

<[Click here for detailed documentation](#)>

British Edging (UKIEBritishEdging – v2024)

This subassembly is used to add edging strips, commonly on pavement edges.

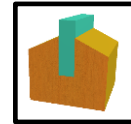

<[Click here for detailed documentation](#)>

British Channel (UKIEBritishChannels – v2024)

This subassembly allows you to add channel blocks.

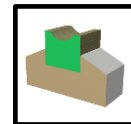

<[Click here for detailed documentation](#)>

Surface Water Channel (UKIESurfaceWaterChannel – v2024)

This subassembly creates a surface water channel.

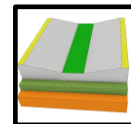

<[Click here for detailed documentation](#)>

1.9.3 Other Road Subassemblies

These are based around the standard 'GenericPavementStructure' subassembly that is built into Civil 3D. They represent simple, lightweight, subassemblies with codes preset for purpose.

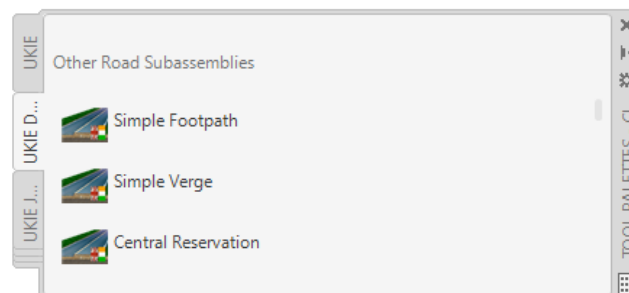

Documentation for the 'GenericPavementStructure' is best viewed by 'right-clicking' the icon on the Tool Palette and selecting 'Help'. This will take you to the current online resource.

You can also view this online documentation by clicking [here](#) .

1.9.4 Rehab Road Subassemblies

These subassemblies are designed to overlay the existing road, then to provide widening at a cross fall that matches the existing road surface.

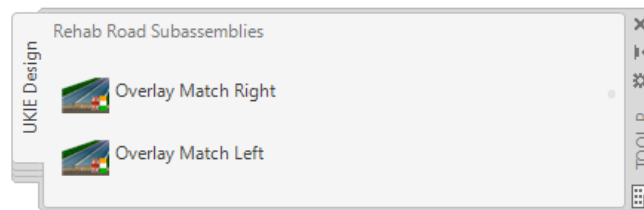

Each variant will be inserted on the appropriately named side of the crown.

Both are based around the generic Civil 3D stock subassembly 'OverlayWidenMatchSlope1' and this is documented [here](#).

1.9.5 Typical Section Sub-Assemblies

These subassemblies are useful for adding commonly used components to the corridor.

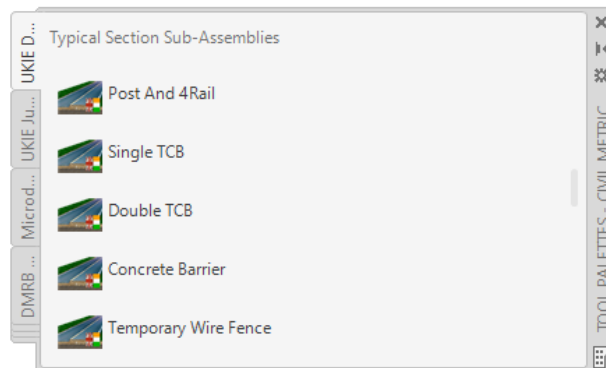

The properties sheet of each component is self-explanatory, and further documentation is deemed unnecessary, and is not available.

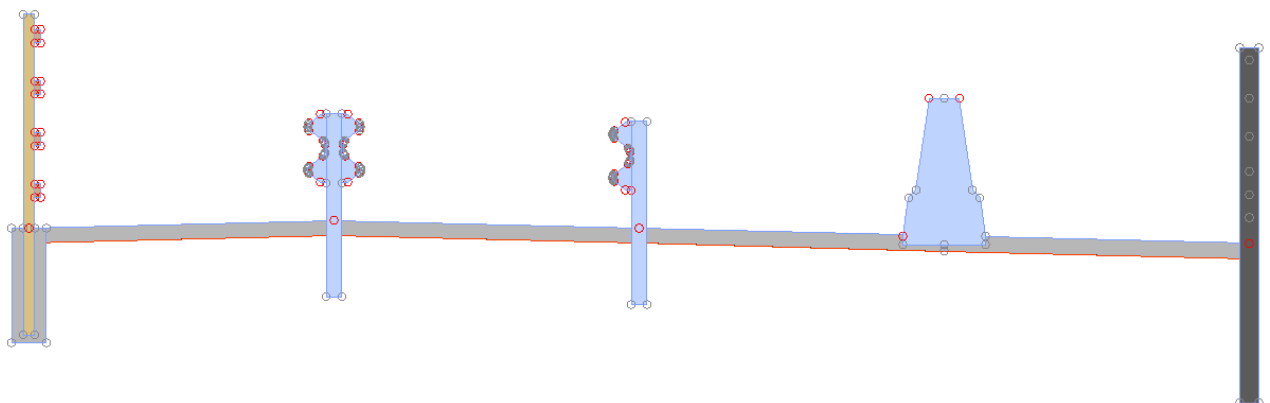

Post And 4Rail, Double TCB, Single TCB, Concrete Barrier and Temporary Wire Fence

1.9.6 Hedge Mark Point

This subassembly is a simple mark point that assigns, by default, a point code of 'Hedge' to the chosen location.



Note: The point is not labeled for you in the assembly design process, but does show as a styled FeatureLine (using the UKIE drawing template), in plan, when a corridor is created from the assembly.

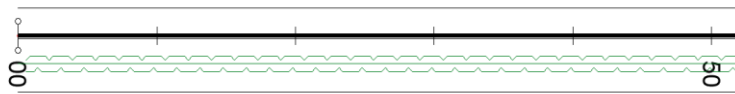

Corridor showing styled Mark Point 'Hedge'

1.9.7 Dynamic Turning Heads

These are not 'Sub-Assemblies', they are AutoCAD Dynamic blocks and are designed to help you get the correct geometry when designing turning heads.

The outside lines show the path of an alignment, which, when profiled, will host the baseline of a corridor. The interior lines represent paths of alignments that will, once profiled, make up the targets for the carriageway subassemblies used in the kerb return assembly.

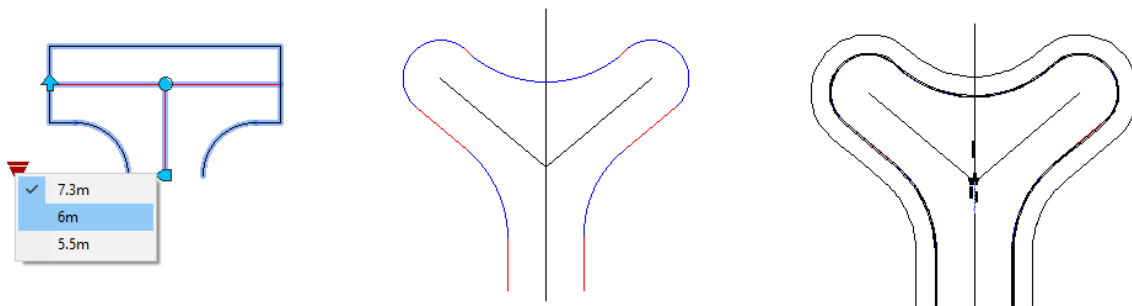
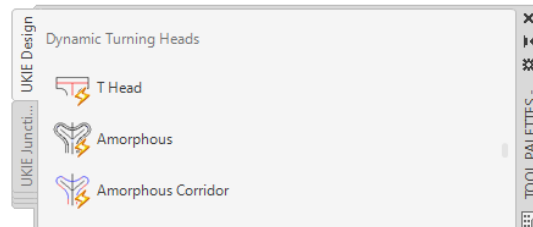

Dynamic Turning Head Blocks

1.9.8 Legacy Sub-Assemblies

This section in the previous release of the country kit contained older subassemblies. These deprecated subassemblies have now been moved to a new tool palette called 'UKIE – Legacy Subassemblies'.

1.9.9 Design Standards

This area includes a link to a reference spreadsheet which outlines the relationship between design speeds and the 'q' values, of 0.6 and 0.9, as demanded by the CD109 standard.

This helps interpret the data shown in the alignment tables, in terms of L, A and RL.

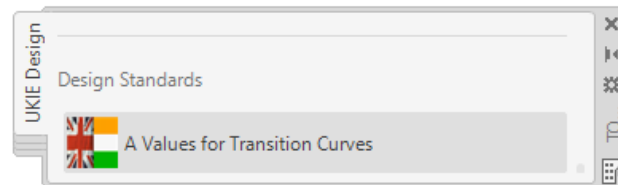

1.10 The 'UKIE Junction Assemblies' Tool Palette

There are three sets of Junction Assemblies in Civil 3D 2023:

- Junction Assemblies (2023)
- Basic Estate Road Junction Assemblies (Legacy)
- Junction Assemblies (Legacy)

The new 2023 Assemblies, such as 'UKIE_MultiKerbs' give you more flexibility in Junction Design.

The older Junction Assemblies use the 'Legacy Sub-Assemblies', which may give less functionality, but have a smaller overhead and are often easier to understand.

All three sets are serviced by the 'Junction\Intersection' wizard (see [Using the Junction Design Wizard](#)).

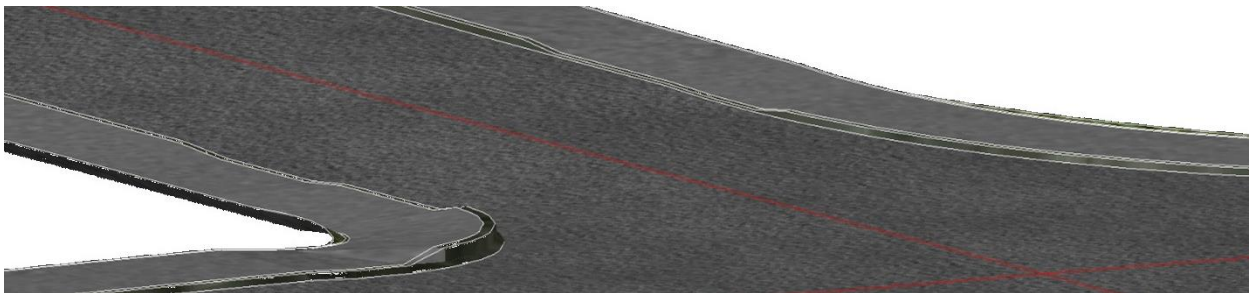

Modified junction created by the junction wizard, using 'Junction Assemblies (2023)', after manipulation of the 'UKIE Multikerbs' subassembly to create a high containment kerb return and a kerb drop

1.10.1 Junction Assemblies (2023)



These assemblies take advantage of the sub-assemblies, such as 'UKIE_Multikerbs', added in the 2021 and 2022 releases of the country kit.

Each one is detailed below:

Full Carriageway

As expected, this assembly is used in areas of a junction that do not interact with the secondary road.

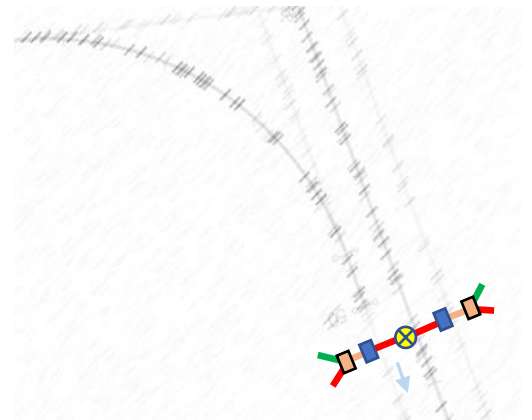
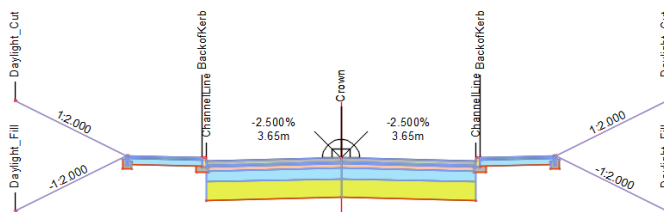

Full Road No Kerbs

This assembly is used to fill the area of the junction between the two bellmouths of a crossroad. No Channelline codes are present.

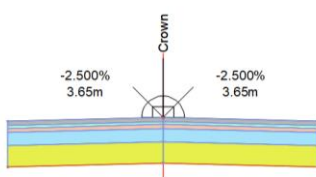

Half Road LHS & Half Road RHS

The half road sections are required in regions of the junction where the opposing lane is designed from the kerb return.

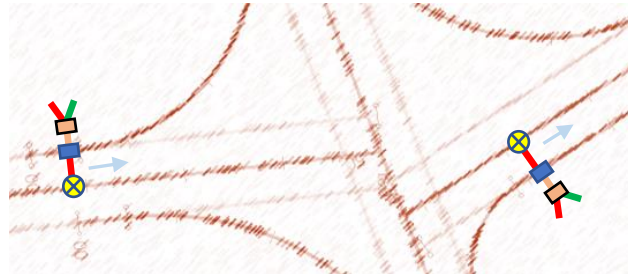
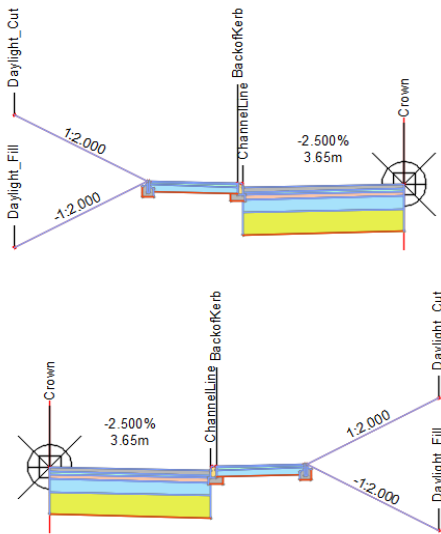

Footpath LHS Part Carriageway & Footpath RHS Part Carriageway

These assemblies are for when the junction bellmouth is defining the edge of the primary road. No ChannelLines are present on the side that targets the bellmouth.

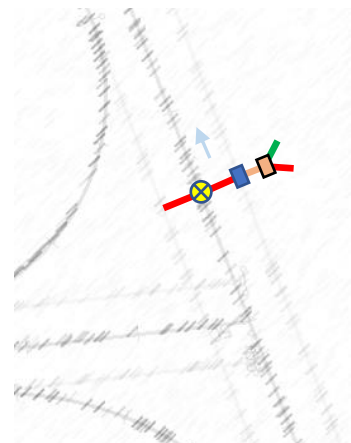
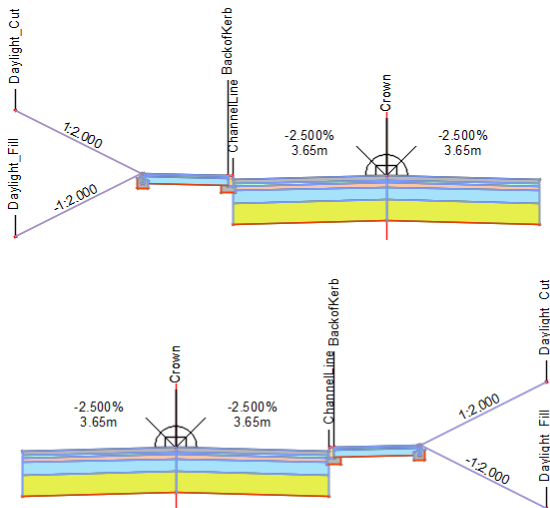

Kerb Return – Lane LHS & Kerb Return Lane RHS

The 'Kerb Return' assemblies are fundamental to the process of junction design. As a baseline they will use a connected 'Kerb Return' alignment and the carriageway will either target the crowns of the main alignments or their offsets. Care should be taken to ensure a sample point is added to the corridor at the point where the alignments or offsets cross.

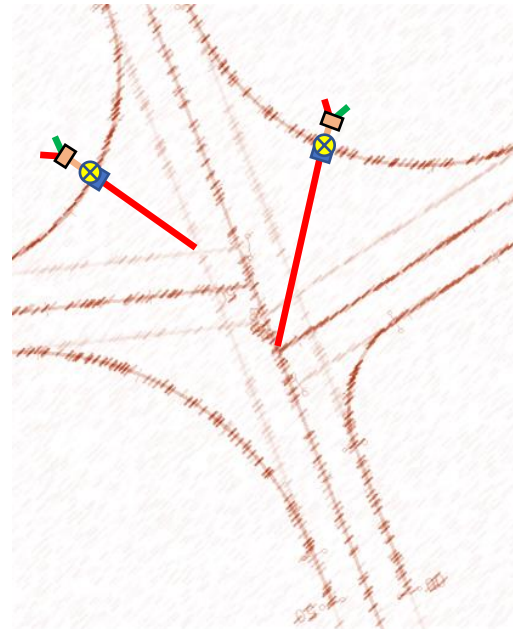
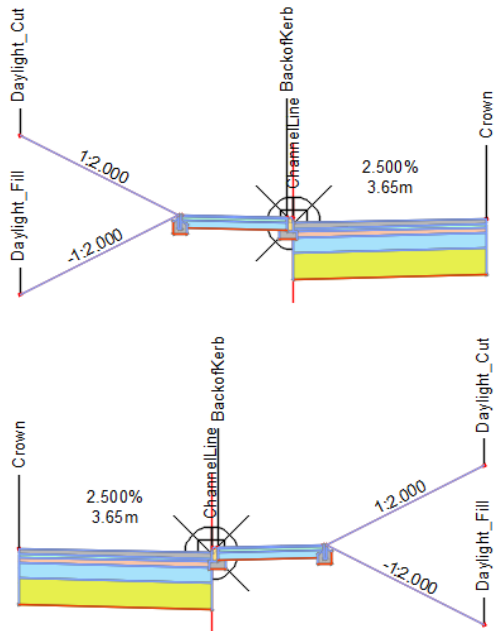

1.10.2 Basic Estate Road Junction Assemblies (Legacy)

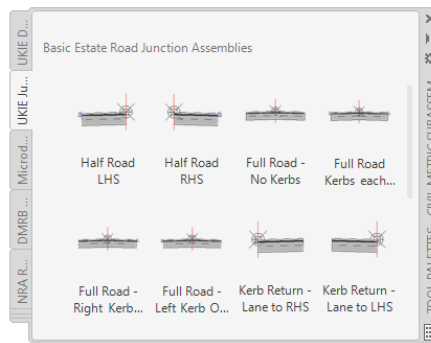

These assemblies consist of only Left and Right carriageways with kerb(s) attached at the Channel Line. They represent the most basic assemblies to create a junction.

The diagram below shows where some of these assemblies would be useful in the design of a junction. The available handed variants of some of these assemblies would be useful should the junction be turning to the opposite side.

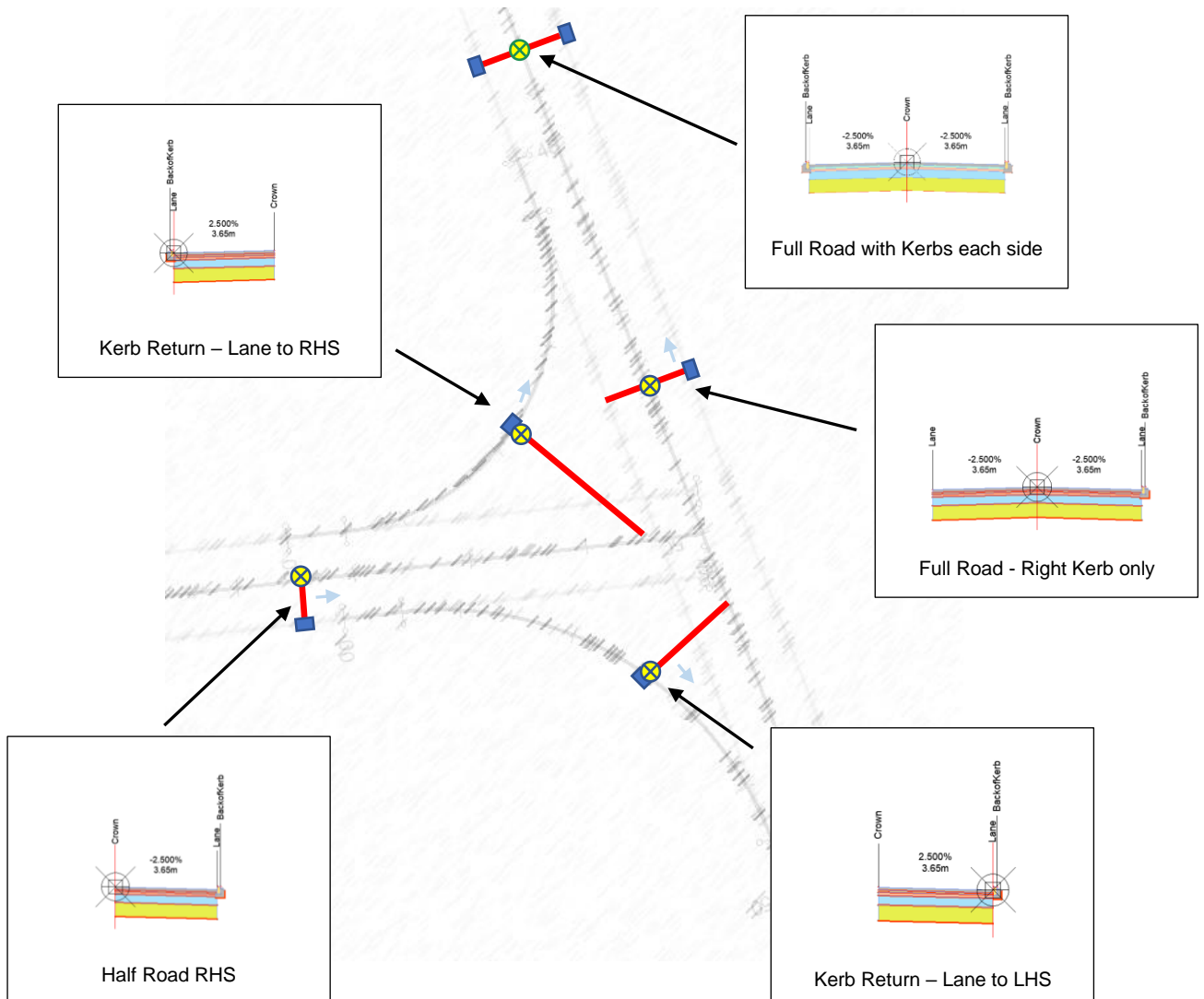

1.10.3 Junction Assemblies (Legacy)

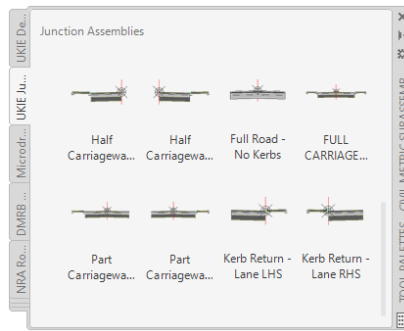

The 'Junction Assemblies' section contains a more complex assembly design. They include carriageway(s), kerb(s), footpath(s), edging(s) and earthwork(s).

The diagram below shows where some of these assemblies in a more complex crossing junction. Handed variations are useful for the opposite sides, if needed.

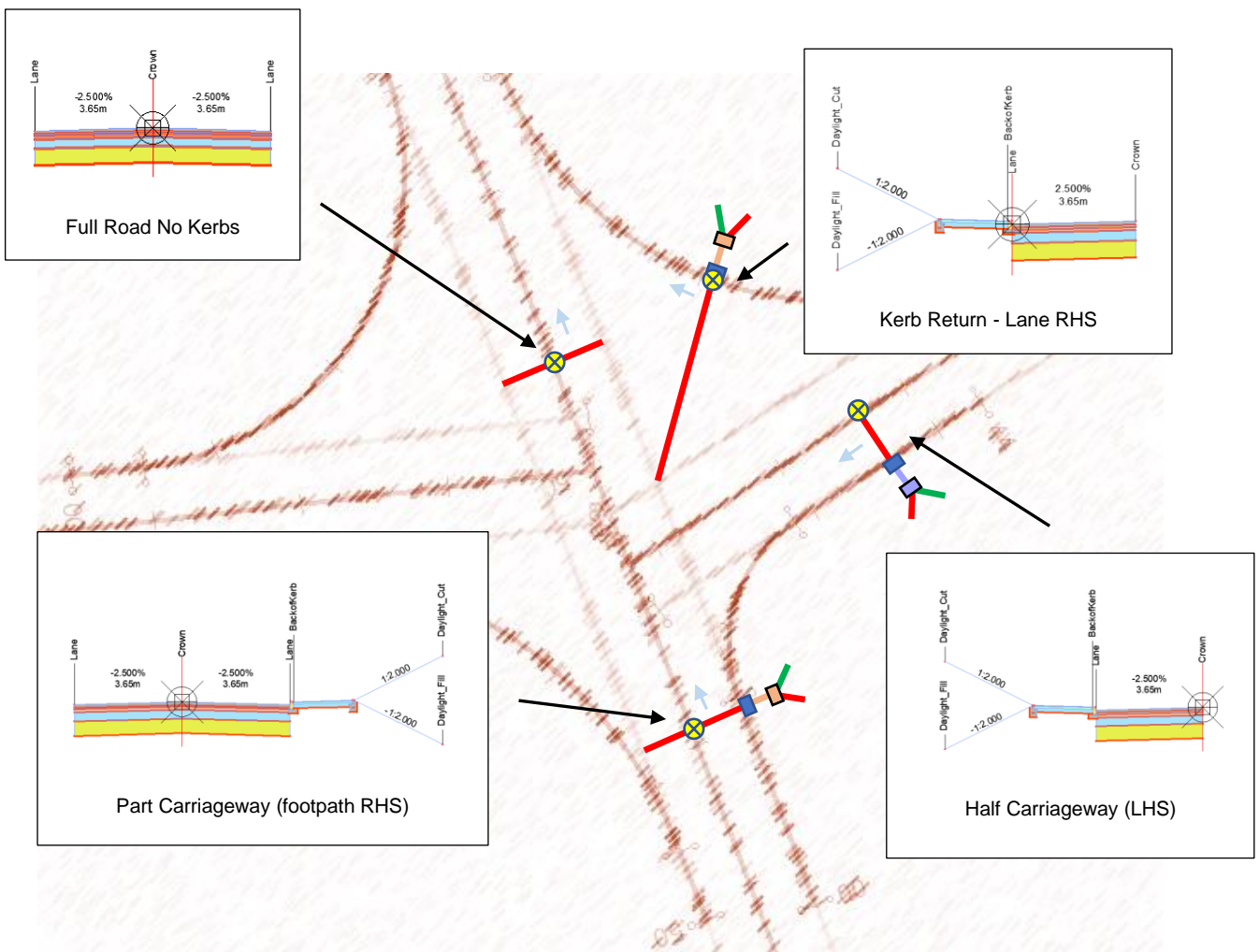

1.10.4 Using the Junction Design Wizard

All UKIE junction assemblies can be used with the junction\intersection wizard.

The junction\intersection wizard will create a junction based on just two profiled alignments. The UKIE template sets the defaults for 2.5% crossfall and 3.65m carriageway width. These can be changed at the time of running the wizard.

Three assembly sets are available to import during the wizard, each matches the corresponding set found on the tool palette.

Assembly Set Name	Based on
Estate Road Junction Set – v2.xml	Junction Assemblies (2023)
Estate Road Junction Set.xml	Junction Assemblies (Legacy)
Basic Estate Road Junction Set.xml	Basic Estate Road Junction Assemblies (Legacy)

The assembly sets can be imported on the ‘Corridor Regions’ tab of the junction\intersection wizard. You may need to browse to the location of the .xml files. These can be found in the following location:

‘C:\ProgramData\Autodesk\C3D 2024\<en?>\Assemblies\UKIE’

(where <en?> represents the language version of Civil 3D that is installed)

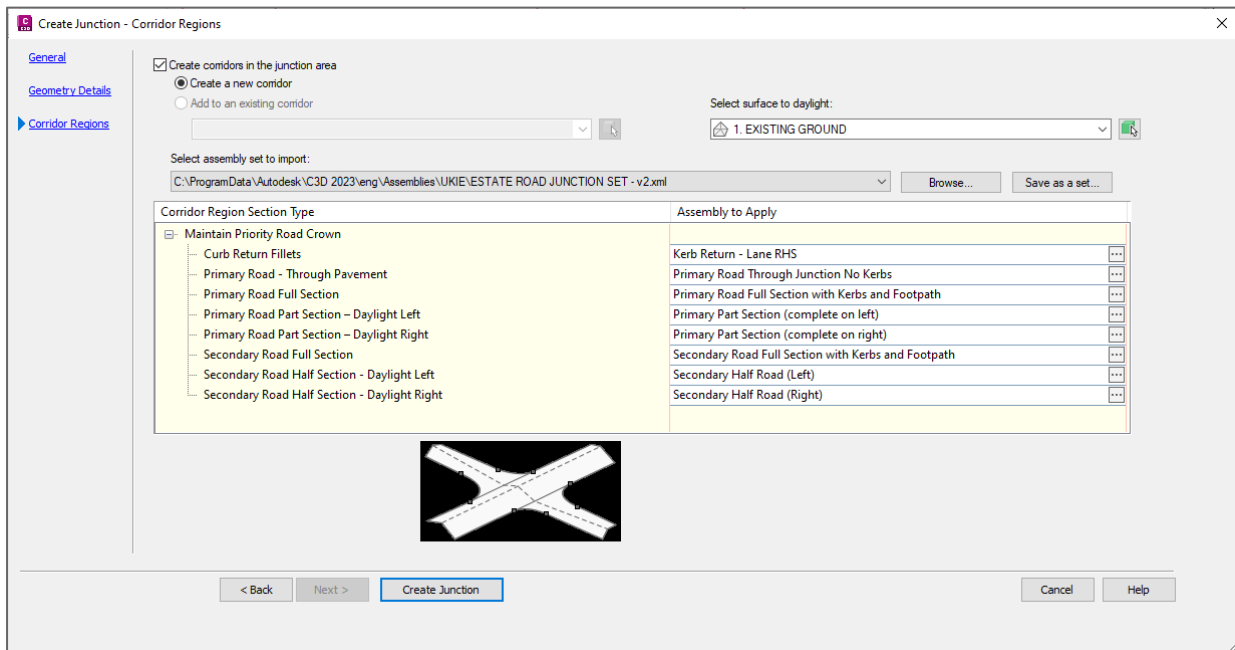

1.11 MicroDrainage

The MicroDrainage Tool Palette contains subassemblies supplied by Innovyze for use within Civil 3D.

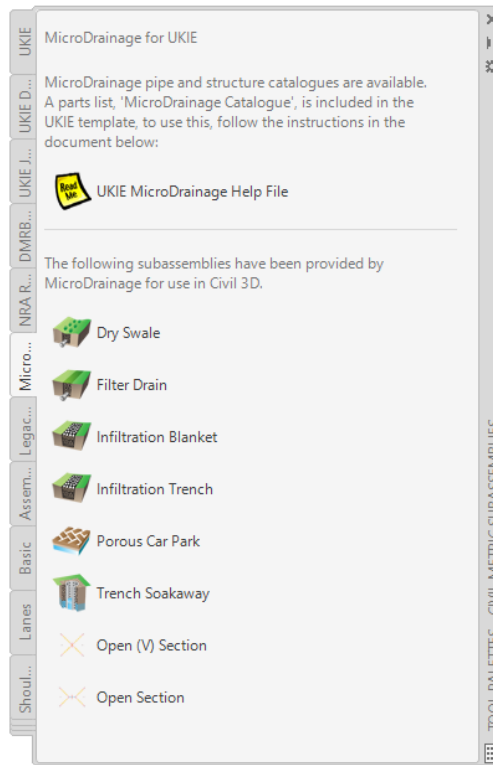

It is documented separately in the following .PDF:

[Documentation for the UKIE MicroDrainage Tool Pallet](#)

1.12 DMRB Road Sections

This Tool Palette contains a number of full Assemblies to match the 'Design Manual for Roads and Bridges' specifications for the UK.

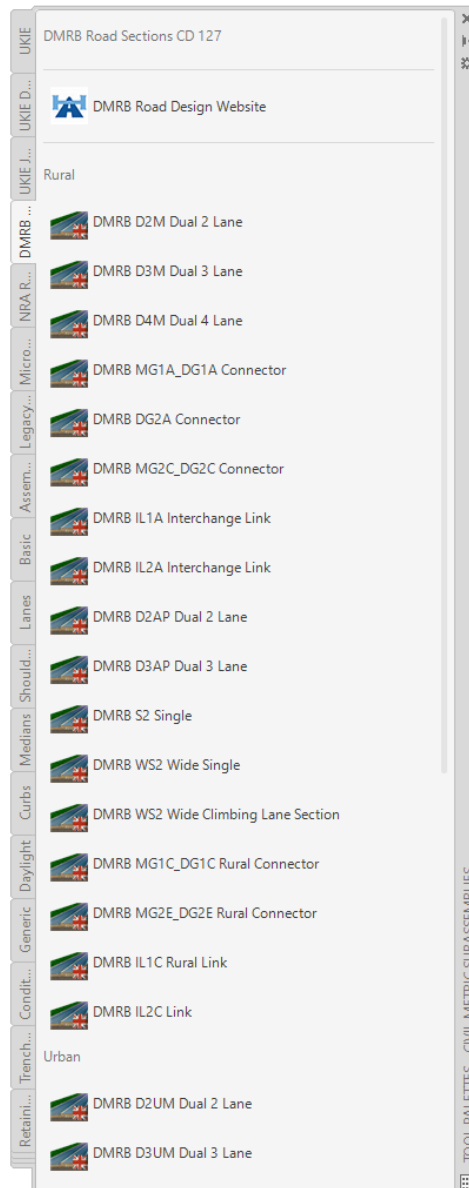

Each section is based on designs outlined 'Standards for Highways' documentation. Visit the following link for further information:

[DMRB - CD127 – Cross Sections and Headrooms.](#)

1.13 NRA Road Sections

This Tool Palette contains a number of full Assemblies for the Eire NRA design specifications. (Based on TD27)

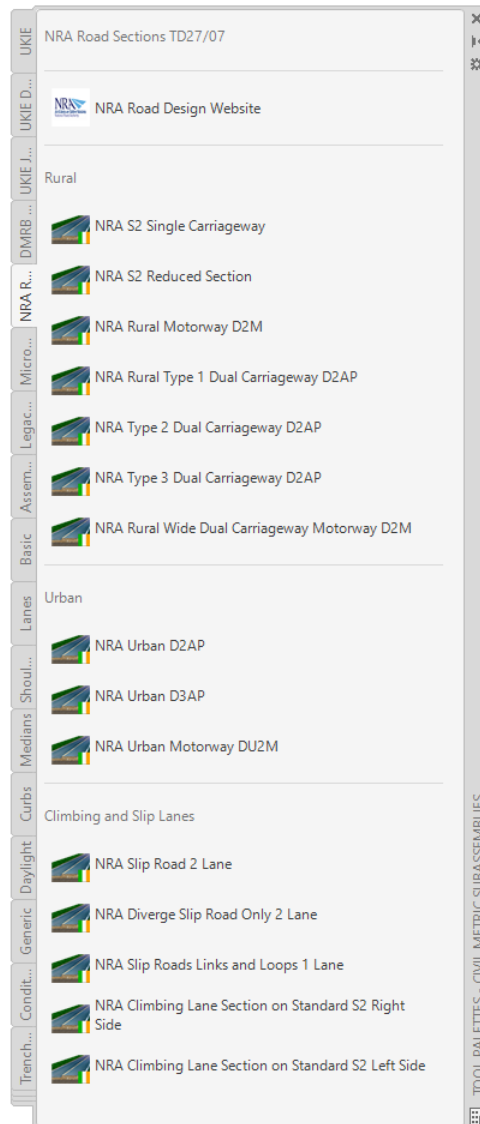

Visit the following website for further information on NRA Standards.

[TII Publications – NRA TD 27 Document](#)

1.14 Legacy UKIE Subassemblies

This tool palette was introduced in the 'UKIE Country Kit 2024' and is the home for subassemblies that are considered depreciated or legacy.

1.14.1 Typical Road Subassemblies (Legacy) and British Standards (Legacy)

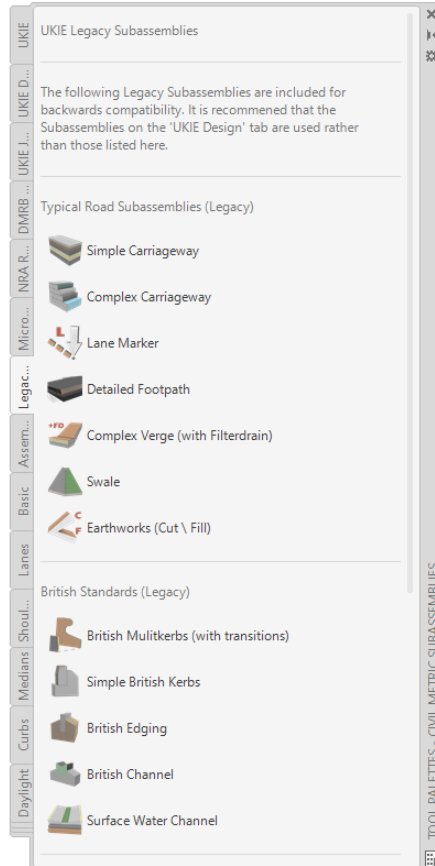

The subassemblies contained in these sections are the 2023 variants of similar items contained on the 'UKIE Design' tab.

These will continue to remain accessible to users to ensure that older drawings containing these subassemblies will open without error. All these subassemblies use the older 'compiled' method of reference, they do not support versioning and have documentation in the older '.chm' format. Notwithstanding this, the functionality of each should not differ from their 2024 counterparts.

1.14.2 Older Legacy Subassemblies

The subassemblies here are very old versions that were replaced in the 2019 version of the country kit.

They continue to be supported (for now) to ensure older drawings open without error. Those marked as 'depreciated' maybe removed in the future.

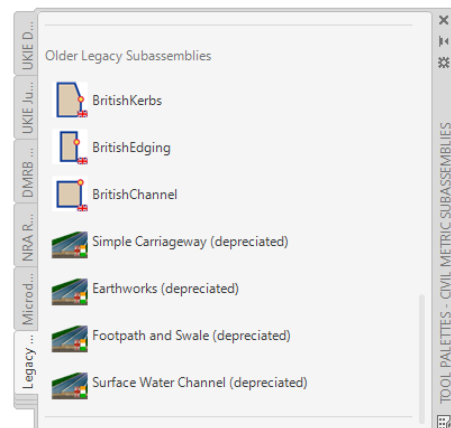

2.0 Drawing Template

2.1 Overview

2.1.1 Default UKIE Template

The UKIE Country Kit for Civil 3D 2024 includes a drawing template that gives you many useful pre-sets for working on projects in the UK and Eire. The drawing template is:



[_Autodesk Civil 3D 2024 UKIE.dwt](#)
AutoCAD Template

When the Country Kit is installed, it will set this drawing template as the default. The location of the template is stored, by default, in your profile directory under the following path:

..\<userprofile>\AppData\Local\Autodesk\C3D 2024\en?\Template

Using the template will give you the following benefits:

- Default Layers based on Uniclass 2015
- Code sets for Assembly design, Corridor Plans and Sections
- Additional Civil 3D styles for most components
- Additional Civil 3D labels for most items
- Support for CD109 Design Standards
- Pre-configured Pipe and Structure parts lists

2.1.2 GG-184 Template

A second template is available to support the DMRB document 'GG184 - Specification for use of Computer Aided Design'. This template matches the UKIE default template but uses a slightly different layering structure to match that demanded in the GG184 document.



[_Autodesk Civil 3D 2024 GG184.dwt](#)
AutoCAD Template

To use this template select it when creating a new drawing.

2.2 Uniclass 2015 Layer Structure

2.2.1 Overview

The template uses a layer system based on the Uniclass 2015 layering system. An example of a typical layer name is shown below, with its composition highlighted.

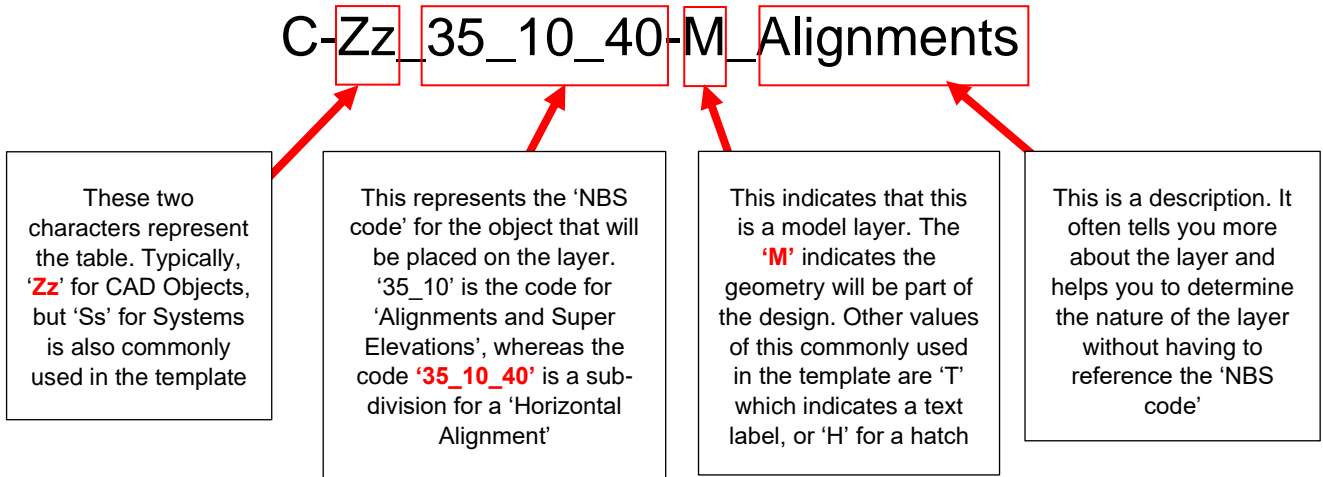

To find out more about 'Uniclass 2015' – visit the NBS website by clicking [here](#).

2.2.2 Civil 3D Object Defaults

Whenever you add a Civil 3D Object using the UKIE Template it will automatically place the object on a 'Uniclass' layer. The 'Object Defaults' for the 2022 template are shown below:

Object	Layer	Object	Layer
Alignment	C-Zz_35_10_40-M_Alignments	Pipe-Labeling	C-Zz_20_10_45-T_Labels
Alignment-Labeling	C-Zz_35_10_40-T_Alignments	Pipe and Structure Table	C-Zz_30_90-M_Tables
Alignment Table	C-Zz_30_90-M_Tables	Pipe Network Section	D-Ss_50_35_08-M_PipeNetworkSection
Appurtenance	D-Ss_50_35_10-M_PressurePipeAncillaries	Pipe or Structure Profile	C-Zz_35_10_90-M_Profiles
Appurtenance-Labeling	D-Ss_50_35_10-T_PressurePipeEquipment	Point Table	C-Zz_30_90-M_Tables
Assembly	C-Zz_70_80-M_Assemblies	Pressure Network Section	D-Ss_50_35_10-M_PressurePipeSection
Building Site	S-Ss_20-M_BuildingSites	Pressure Part Profile	D-Ss_50_35_10-M_PressurePipePartProfile
Cant View	R-Zz_35_10_80-M_CantView	Pressure Part Table	C-Zz_30_90-M_Tables
Catchment	D-Ss_50_30_02-M_CatchmentAreas	Pressure Pipe	D-Ss_50_35_10-M_PressurePipePipes
Catchment-Labeling	D-Ss_50_30_02-T_CatchmentAreas	Pressure Pipe-Labeling	D-Ss_50_35_10-T_PressurePipePipes
Corridor	C-Zz_35-M_Corridors	Profile	C-Zz_35_10_90-M_Profiles
Corridor Section	C-Zz_35-M_CorridorSection	Profile-Labeling	C-Zz_35_10_90-T_Profiles
Crossover Group	R-Pr_20_76_71_17-M_Crossovers	Profile View	C-Zz_70_80-M_ProfileViews
Feature Line	C-Zz_80_45-M_FeatureLines	Profile View-Labeling	C-Zz_70_80-T_ProfileViews
Fitting	D-Ss_50_35_10-M_PressurePipeFitting	Sample Line	C-Zz_60_50_80-M_SampleLines
Fitting-Labeling	D-Ss_50_35_10-T_PressurePipeFitting	Sample Line-Labeling	C-Zz_60_50_80-T_SampleLines
General Note Label	C-Zz_20_10_45-T_Labels	Section	C-Zz_70_80-M_Sections
General Segment Label	C-Zz_20_10_45-T_Labels	Section-Labeling	C-Zz_70_80-T_Sections
Grading	C-Ss_15_10_30-M_Grading	Section View	C-Zz_70_80-M_SectionViews
Grading-Labeling	C-Ss_15_10_30-T_Grading	Section View-Labeling	C-Zz_70_80-T_SectionViews
Grid Surface	C-Zz_40-M_Surfaces	Section View Quantity Takeoff Table	C-Zz_30_90-M_Tables
Grid Surface-Labeling	C-Zz_40-T_Surfaces	Sheet	C-Zz_10_20-M_Sheets
Interference	D-Ss_50_35_08-M_PipeNetworkInterferences	Structure	D-Ss_50_35_08-M_PipeNetworkStructures
Intersection	C-SL_80_35_44-M_JunctionWizardJunctions	Structure-Labeling	D-Ss_50_35_08-T_PipeNetworkStructures
Intersection-Labeling	C-SL_80_35_44-T_JunctionWizardLabels	Subassembly	C-Zz_70_80-M_SubAssemblies
Mass Haul Line	C-Ss_15_10_30_25-M_MasshaulLine	Superelevation View	C-Zz_35_10_80-M_SuperelevationView
Mass Haul View	C-Ss_15_10_30_25-M_MasshaulView	Surface Legend Table	C-Zz_30_90-M_Tables
Match Line	C-Zz_60_55-M_MatchLines	Survey Figure	G-Ac_15_80-M_SurveyFigures
Match Line-Labeling	C-Zz_60_55-T_MatchLines	Survey Figure-Labeling	G-Ac_15_80-T_SurveyFigures
Material Section	Q-FI_50_10-M_QTOMaterialSections	Survey Figure Segment Label	G-Ac_15_80-T_SurveyFigures
Material Table	C-Zz_30_90-M_Tables	Survey Network	G-Ac_15_80-M_SurveyNetworks
Parcel	C-Zz_50_60-M_Plots	Tin Surface	C-Zz_40-M_Surfaces
Parcel-Labeling	C-Zz_50_60-T_Plots	Tin Surface-Labeling	C-Zz_40-T_Surfaces
Parcel Segment	C-Zz_20_10_45-T_Labels	Turnout	R-Pr_20_76_71_91-M_Turnouts
Parcel Segment-Labeling	C-Zz_20_10_45-T_Labels	View Frame	C-Zz_70_60-M_ViewFrames
Parcel Table	C-Zz_30_90-M_Tables	View Frame-Labeling	C-Zz_70_60-T_ViewFrames
Pipe	D-Ss_50_35_08-M_PipeNetworkPipes		

2.2.3 Layer Filters

The Layer Filters shown alongside are available inside the 'Layer Properties' dialogue box, each filter contains only layers appropriate to the filter name.

The 'RoadMarkings' and 'RoadSigns' layer filters are new for the 2024 template file.

The '_ CIVIL 3D LAYERS' filter can be inverted to show layers that are not part of the declared structure.

Selecting the '_ CIVIL 3D LAYERS (invert for none)' filter and then ticking the 'invert filter' box will usually list layers that did not originate from the UKIE Country Kit 2024.

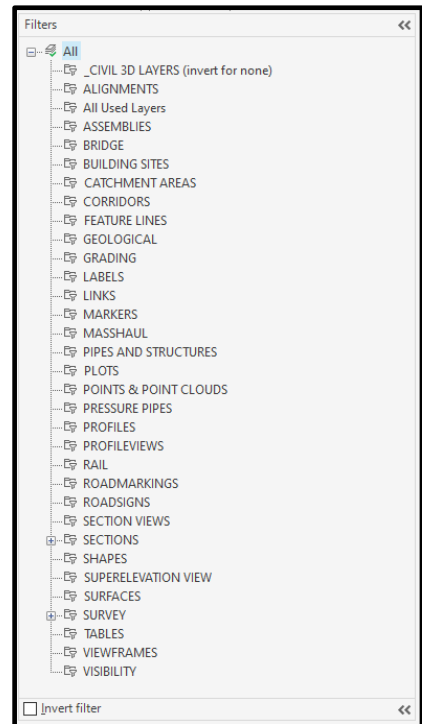

2.2.4 Using the Layering System

As the 'Object Defaults' are set in the template, most of the time you can let Civil 3D do the hard work and let it automatically assign the appropriate layers to the objects you make.

Many Civil 3D 'Styles' and 'Labels' also reference the layer structure. When you use these 'Styles' and 'Labels' they will automatically assign the appropriate layer.

2.2.5 Using Layer Modifiers

No default 'Layer Modifiers' have been assigned to 'Object Defaults' in the template.

To simplify the usage of 'Layer Modifiers' it is recommended that just the 'Description' (after the final '_') is modified.

However, more complex usage may involve consulting the NBS website to explore additional code levels that maybe available to the object that is being created.

2.2.6 Purging layers

It is common practice to use the purge command to remove unneeded layers.

Layers that are defined as 'Object Defaults' or those that are used in Styles or Labels will not be purged out of the drawing.

2.3 Multi-Purpose Styles

2.3.1 Marker Styles

'Marker Styles are used in multiple environments to insert a symbol or block. The following 'Marker Styles' are available.

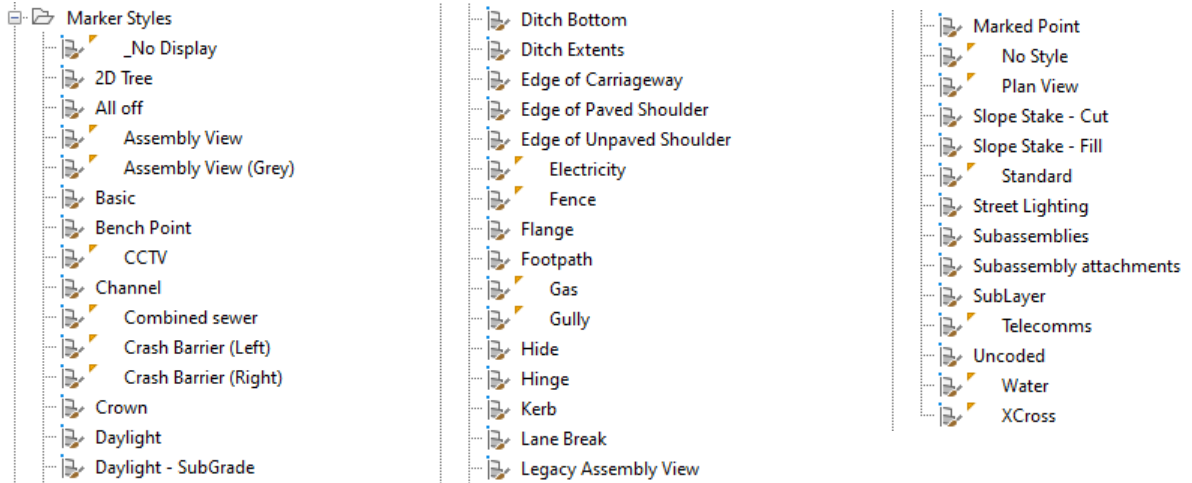

2.3.2 Feature Line Styles

The following 'Feature Line Styles' are available.

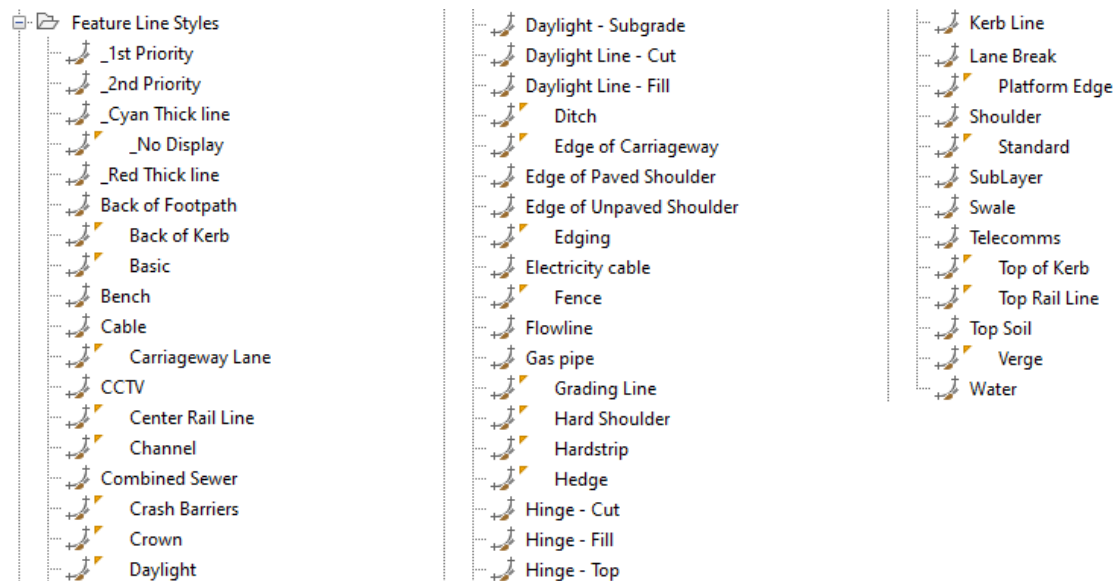

2.3.3 Slope Pattern Styles

The following 'Slope Pattern Styles' are available.

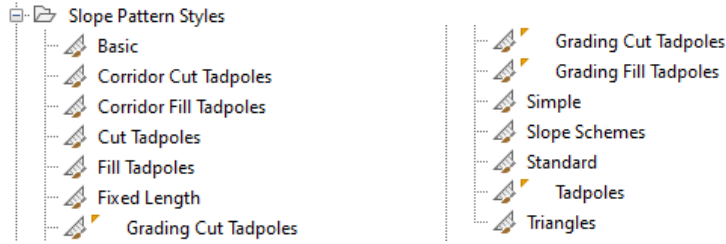

2.3.4 Projection Styles

The following 'Projection Styles' are available:

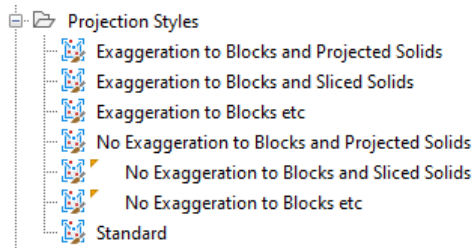

2.3.5 Code Set Styles

'Code Set Styles' control how assemblies are represented in your drawing. Whist other sets exist in the template, there are two automatically assigned during object creation.

UKIE Assembly-Section

As the name suggests this 'Code Set Style' is useful during assembly creation as well as during the setting out of sections. It behaves differently in each scenario.

It will be set automatically when creating an 'Assembly'. It ensures that during assembly design, 'Point, Link and Shape Codes' are set according to aid the design process.

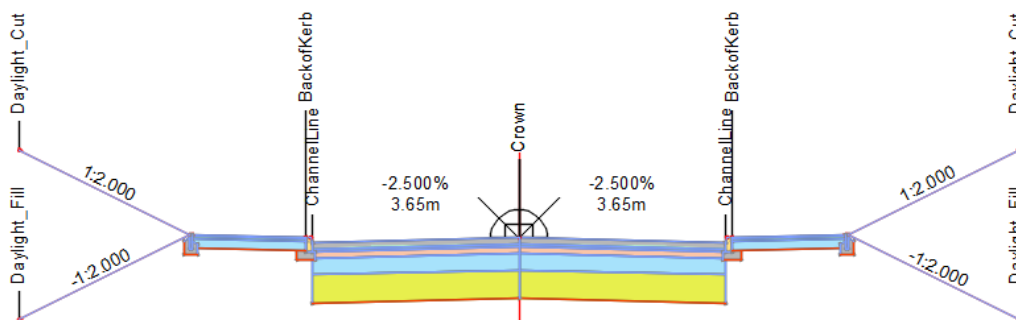

The 'UKIE Assembly-Section' code set controls what is shown during Assembly Creation

It will also be automatically assigned to section views when they are created from a 'Sample Line'. Using view dependency, this means that what you see in a section is detailed differently to what you see in Assembly design, even though they use the same 'Code Set Style'.

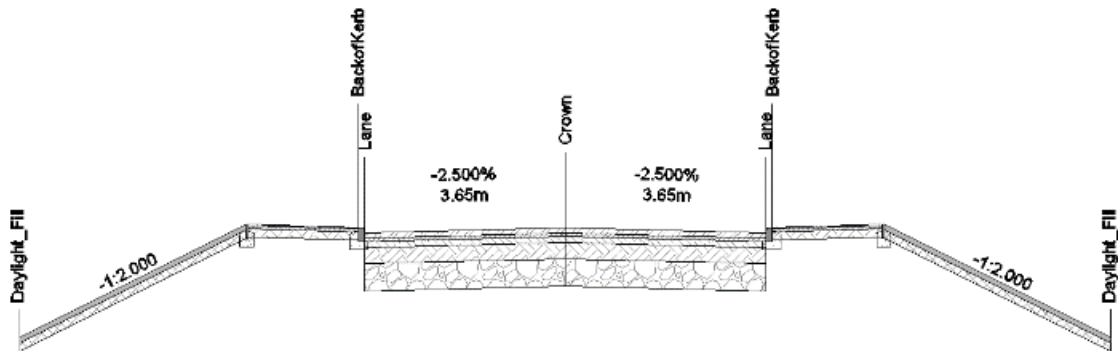

The 'UKIE Assembly-Section' code set controls what is shown in section

UKIE Plan and 3D

As viewing a corridor in plan and 3D requires a differing set of styling to that used above, a second 'Code Style Set' has been included for model visualization purposes. This code set is assigned, by default, to any corridors created in the drawing.

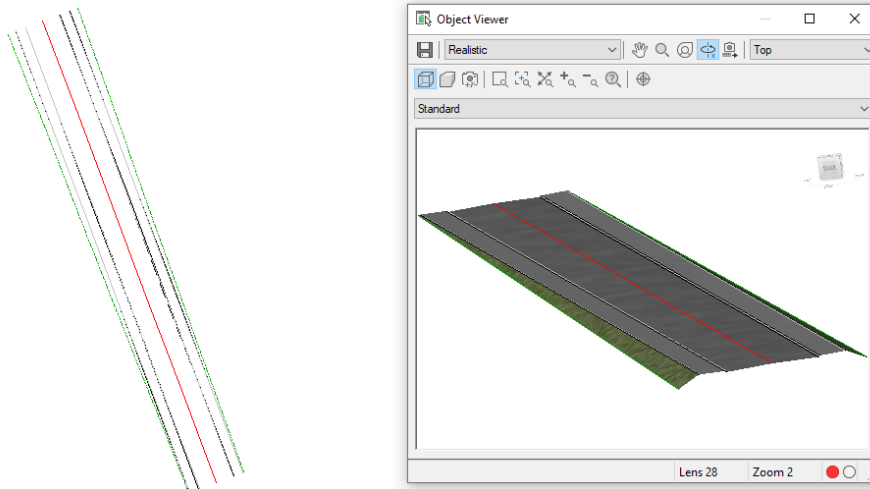

The 'UKIE Plan and 3D' code set style when viewing a corridor in Plan and 3D

Additional Code Set Styles

The following additional 'Code Set Styles' are available. They are included for legacy support.

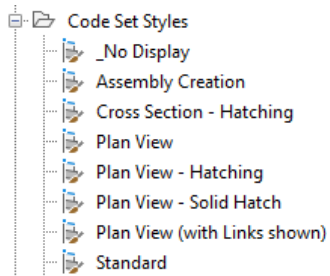

2.3.6 Link Styles

'Link styles' are often used in code sets to determine how the link code is displayed. The following are available. The 'UKIE Formation' style was introduced in 2021.

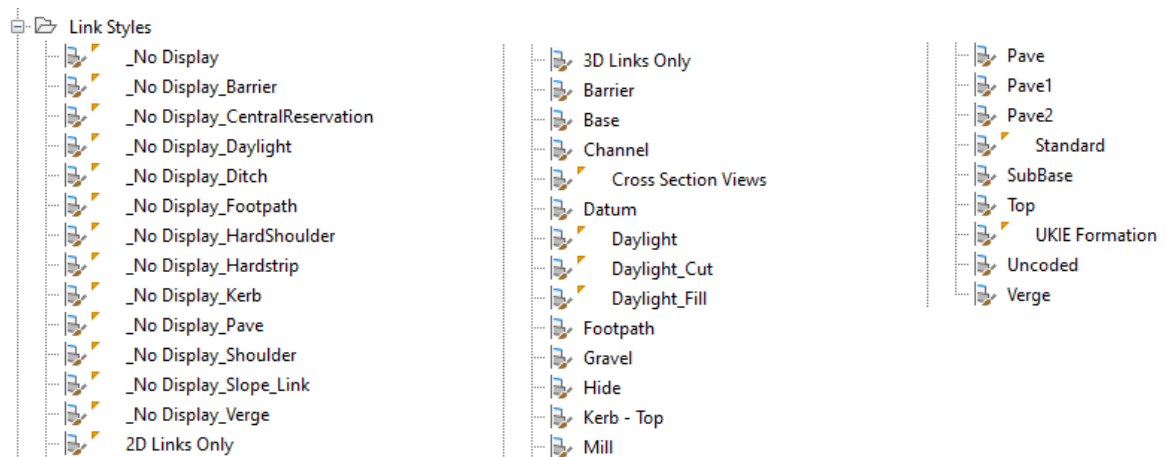

2.3.7 Shape Styles

'Shape Styles' are often used in code sets to determine how the shape code is displayed. The following are available. The UKIE variants were introduced in 2021.

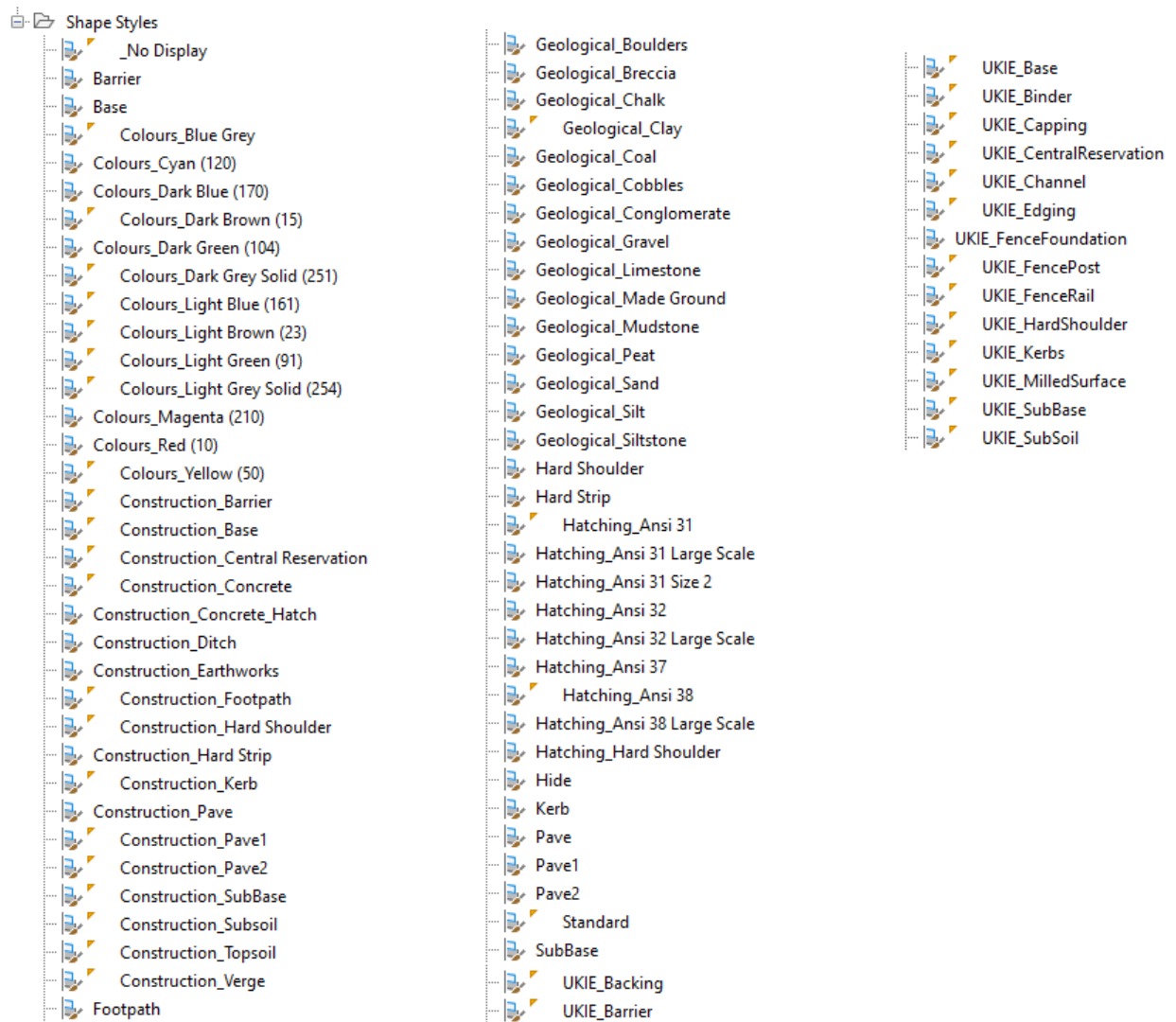

2.3.8 General Label Styles

The following 'General Label Styles' are included in the template:

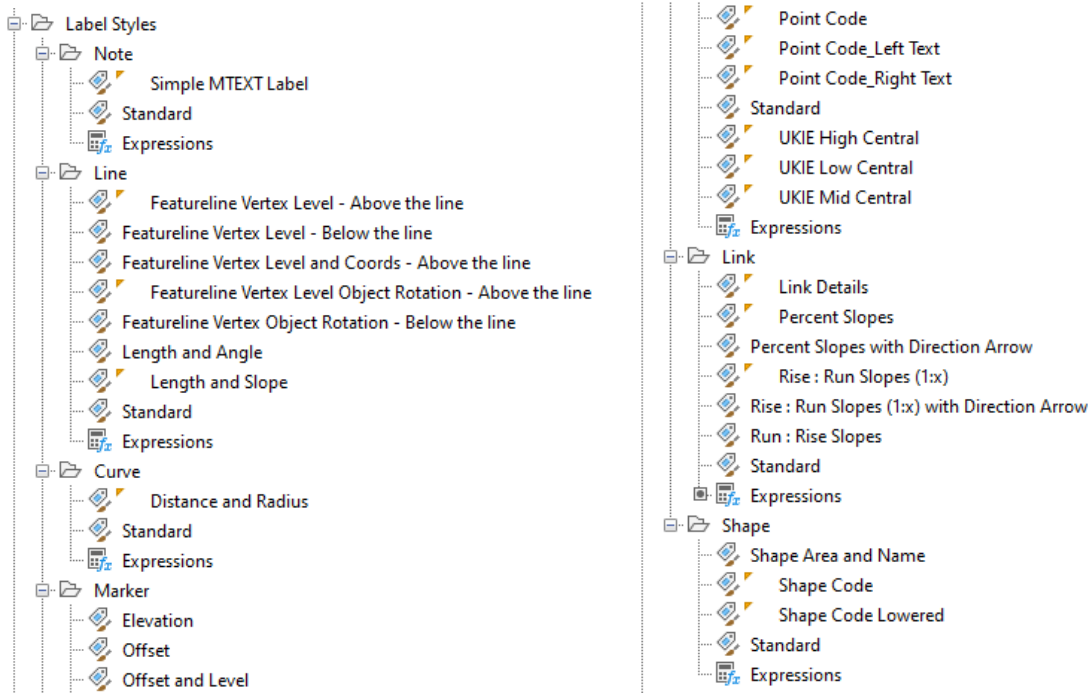

The UKIE Marker 'Label Styles' are used extensively in the code sets to keep text from clashing and to improve readability during assembly design and section creation.

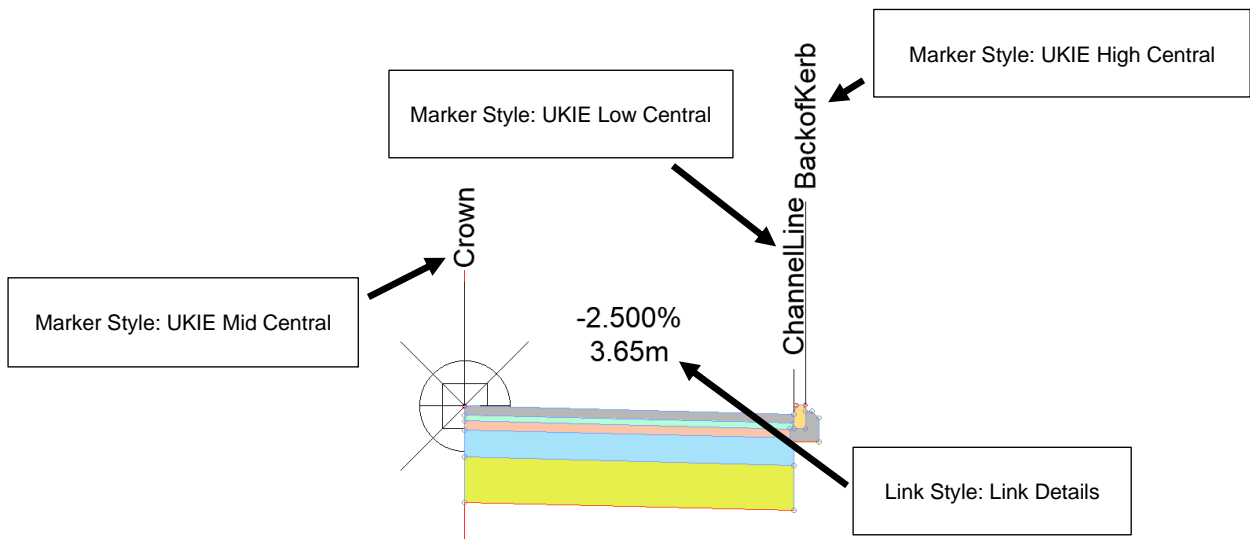

Use of Label Styles in the 'UKIE Assembly-Section' code set

2.4 Point Settings

2.4.1 Point Styles and Point Label Styles

The following 'Point Styles' are available:

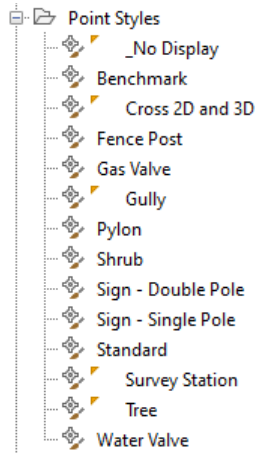

Point A Style = 'Cross 2D and 3D', Point B style = 'Gully'

The following 'Point Label Styles' are available:

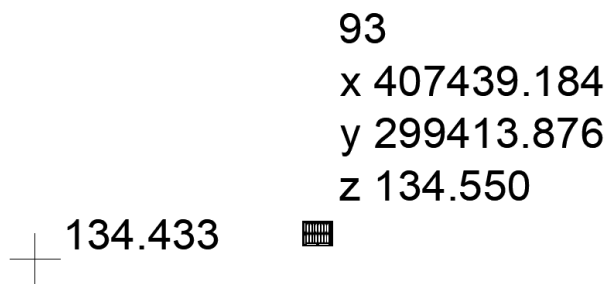
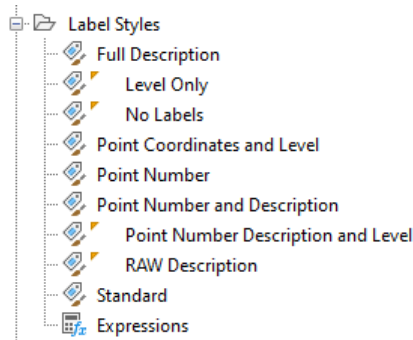

Point A Label = 'Level Only', Point B Label = 'Point Coordinates and Level'

2.4.2 Point File Formats

When importing raw 'Point Files' the following preset file formats can be read.

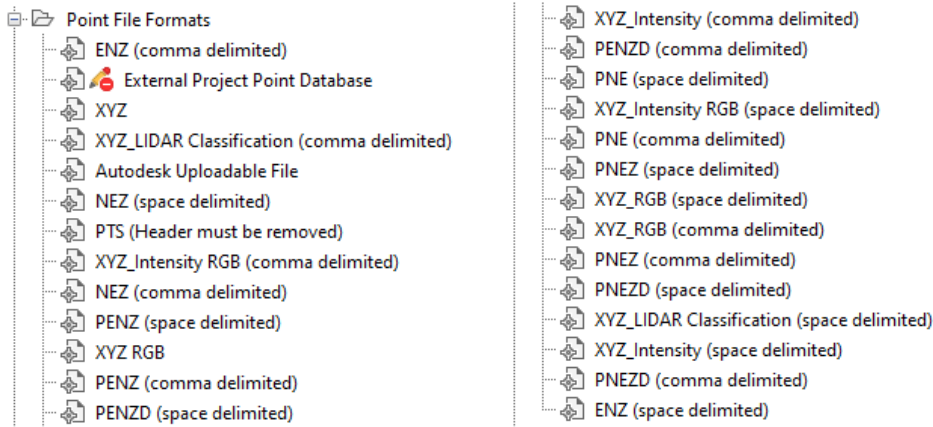

To aid selection: P = Point Number, E = Easting, N = Northing, Z = Level, D = Description

As an example, 'ENZ (comma delimited)' file would contain Easting, Northings and Elevations separated by a comma.

2.4.3 Descriptive Key Sets

Two 'Descriptive Key Sets' are preloaded in the template. 'DMRB Vol 5', which is a set of codes based on the appendix in the DMRB specification, and 'UK and Ireland Sample', which is a sample set for the user to manipulate accordingly.

Note: The search order for these sets are shown below. By default, the 'UK and Ireland Sample' set will take priority. It is common practice to assign these 'Descriptive Keys Sets' by using the 'Apply Description Keys' command to either a point group or a point selection.

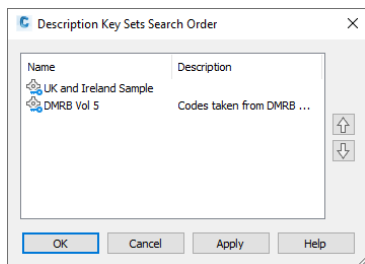

Description Key Set Search Order

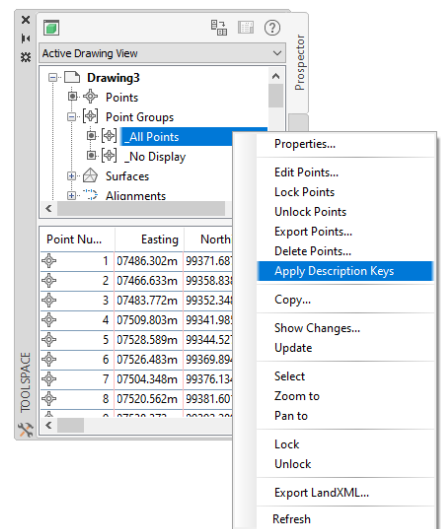

Description Keys to a Point Group

2.4.4 Point Table Styles

One additional 'Table Style' is available, 'Point Table – Coordinates and Levels' and this is presented as the default during point table insertion.

POINT DATA				
POINT NUMBER	EASTING	NORTHING	LEVEL	DESCRIPTION
1	407519.905	299384.246	141.297	PEAV
2	407454.306	299425.662	134.504	GP
3	407517.668	299402.582	135.859	SP
4	407535.052	299480.733	135.131	BKERB
5	407509.871	299343.773	136.763	BLDG

2.5 Surface Settings

2.5.1 Surface Styles

Numerous surface styles are included in the template. When creating a new surface, the default is 'Triangulation'.

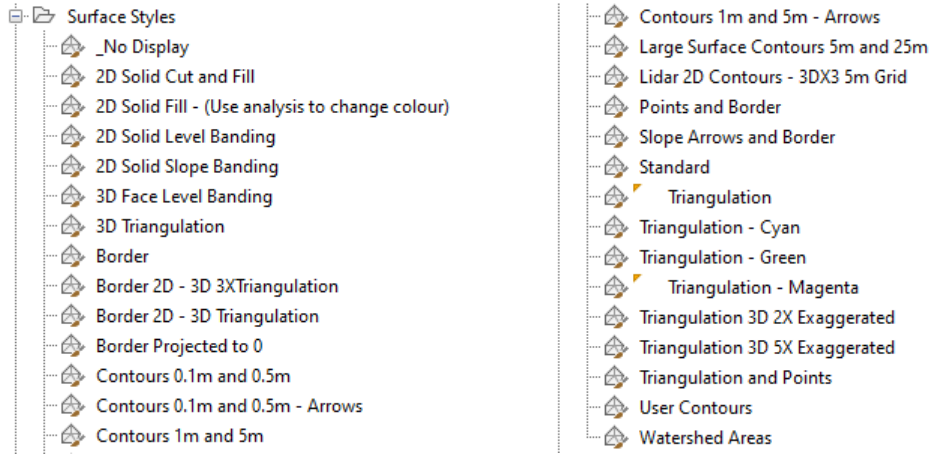

Some of these styles are designed to appear differently in plan to how they look in 3D. For example, the 'Border 2D – 3D 3XTriangulation' style will be displayed as a simple red border in plan. However, when examining the surface in 3D it will change to triangulation exaggerated by a factor of three.

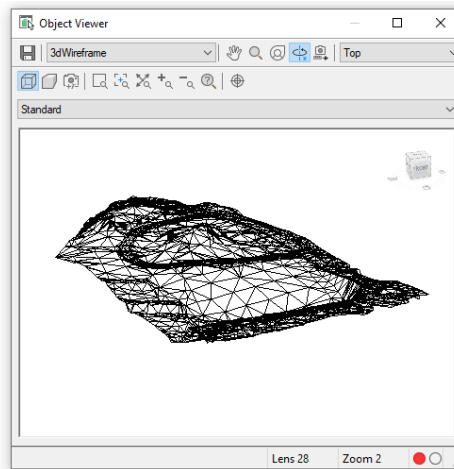
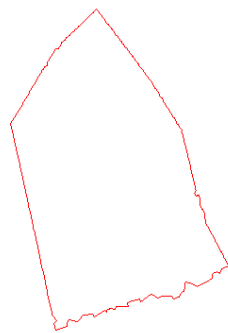

Plan and 3D in some styles maybe different

2.5.2 Surface Label Styles

'Label Styles' exist for Contours, Slopes, Spot Elevations and Watersheds. The 'Legacy' variants are older styles that have been recently improved, but they remain in place and may be retired in the next release.

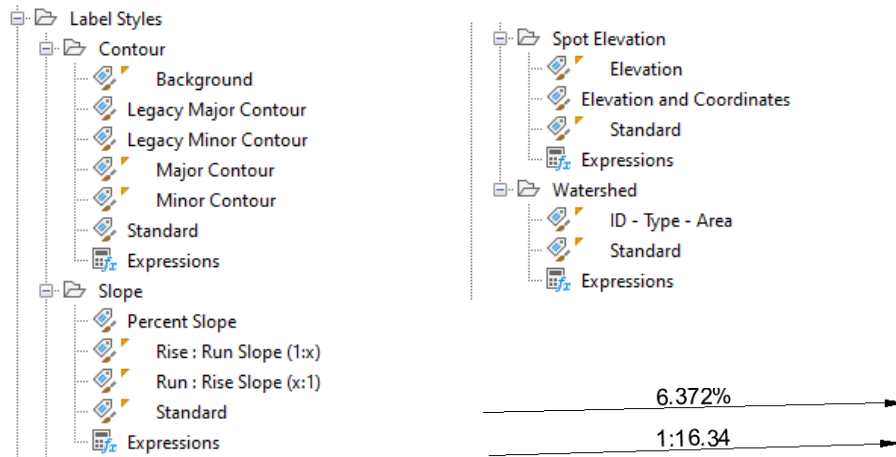

Two slopes, one labeled using 'Percent Slope' and the other using 'Rise: Run Slope (1:x)'

2.5.3 Surface Table Styles

'Surface Tables' can be added to a drawing, referencing a surface, by clicking 'Add Legend' on the ribbon bar with the surface selected. The Table style used is defined on the 'Analysis' tab of the 'Surface Properties' dialogue box.

The 2022 release of the country kit replaced many of the older styles and these newer variants are preceded with '..UKIE'. The older styles remain as 'Legacy' styles but will be retired in the next release of this country kit. The following 'Table Styles' are included for each relevant surface type, as shown below:

The image shows a software interface with a 'Table Styles' tree on the left, a 3D surface model on the right, and a data table below. The 'Table Styles' tree includes folders for 'Direction', 'Level', and 'Slope', each with 'Legacy' and 'UKIE' variants. The 3D model shows a surface with two distinct colored regions: a red region and a green region. Below the model is a table titled 'SURFACE LEVEL DATA'.

NUMBER	MINIMUM LEVEL	MAXIMUM LEVEL	COLOUR	AREA	VOLUME
1	-5.00	0.00	■	253.583m2	101.961m3
2	0.00	5.00	■	264.880m2	101.872m3

An example of using the 'UKIE - Cut and Fill Volumes' Table Style to create a Legend for a volume based surface

2.6 Parcel (Plot) Settings

2.6.1 Parcel Styles

The following 'Parcel Styles' allow you shade the parcel (plots) accordingly:

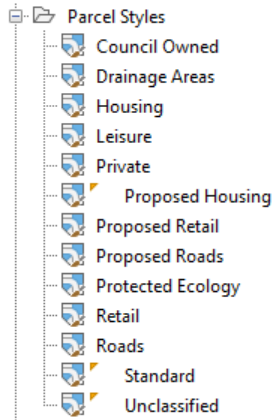

2.6.2 Parcel Label Styles

Lines, Curves and Areas can be automatically, or individually, labeled on the plots. The following 'Label' styles are available and ready to use:

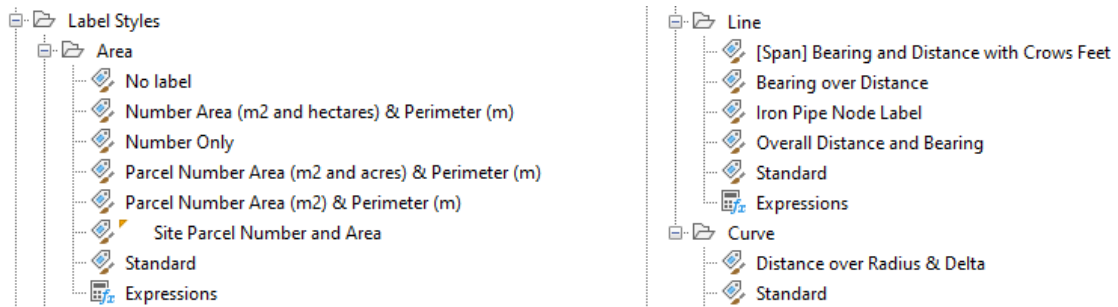

2.6.3 Parcel Table Styles

The following 'Table Styles' are available:

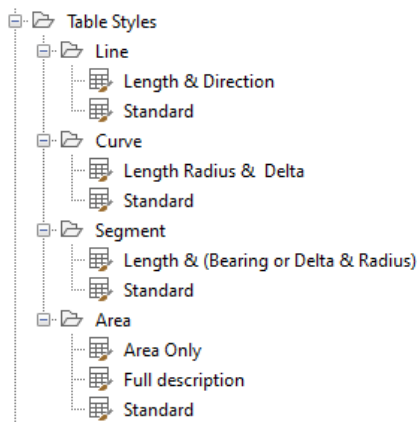

2.7 Grading

2.7.1 Grading Styles

Three simple grading styles exist:

Cut

This style is used when the grade goes into 'Cut' and is basically red lines with red cut tadpoles.

Fill

This style is used when the grade goes into 'Fill' and is basically green lines with green fill tadpoles.

Grading Offset

This style does not include tadpoles and is used when grading is achieved without a reference surface.

2.7.2 Grading Criteria Sets

The follow sets are included in the template.

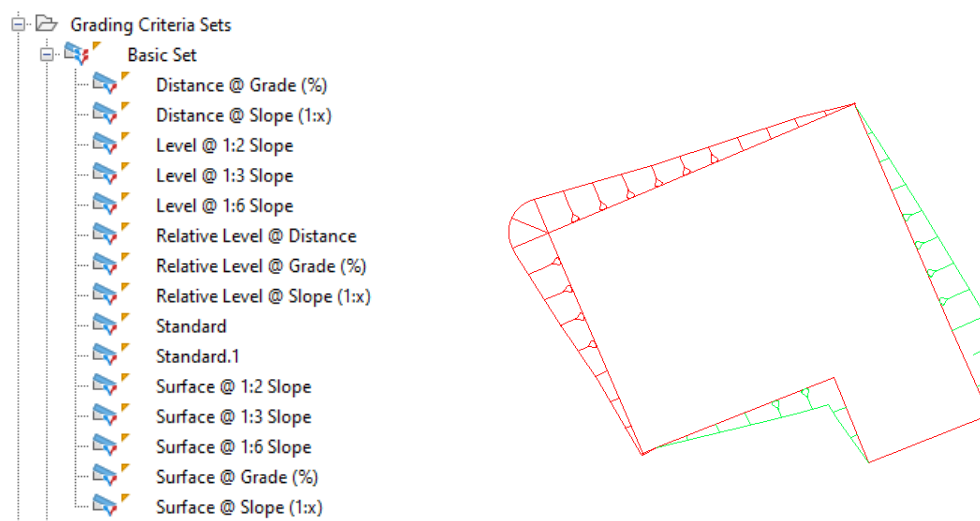

A FFL graded to an existing surface using 'Surface @ 1:2 Slope'

Each 'Grading Criteria Set' can be used to determine how the grading tool performs the Grade, and which variables are used to achieve the result. There are four basic types of grading mechanism - Distance; Level; Relative Level and Surface.

The 'Surface' based sets will target the declared surface from the grading line at the slopes defined in either cut or fill. The other types will achieve the final levels by specifying the two variables required.

All the grading sets allow you to change the variables required on the common line, if, for example, a minor change is required to the slope.

2.8 Alignments

2.8.1 Alignment Styles

When creating an Alignment from the UKIE Template the default style is 'Design Style LWT'. Straights will be displayed in red; Curves will be blue; and Transitions will be green. Other styles are available, as below, and are named appropriately to their usage:

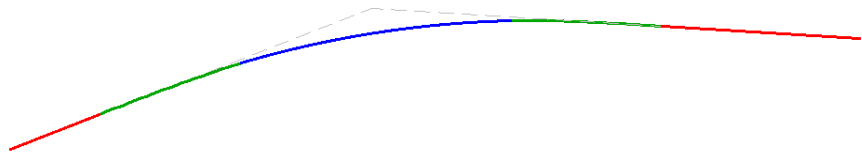
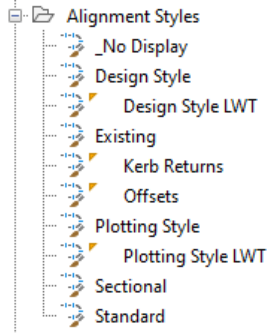

An Alignment (with no labels) using the 'Design Style LWT'

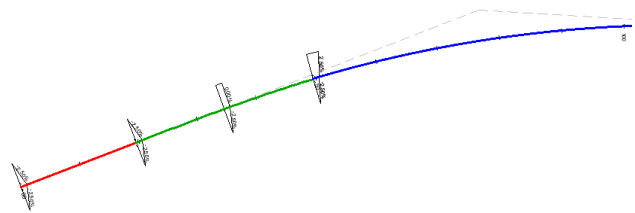
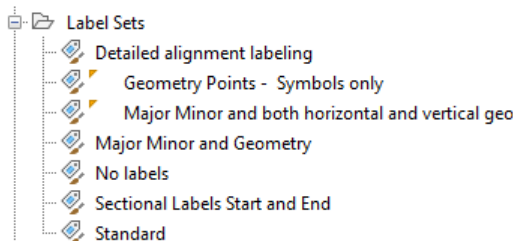

2.8.2 Alignment Label Sets

Labeling alignments can be achieved during their creation by choosing an alignment label set. The default is 'Major Minor and both horizontal and vertical geometry'. Label sets can be changed after creation by right-clicking the Alignment and choosing 'Edit Alignment Labels' then 'Import label set..'

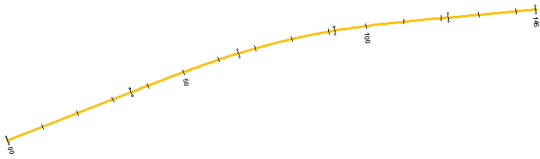

Alignment with assigned Superelevation - labelled with the default label set

Below are some of the other Alignment Style \ Label combinations that can be achieved:

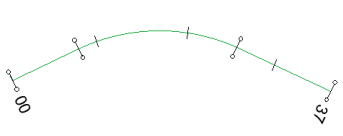
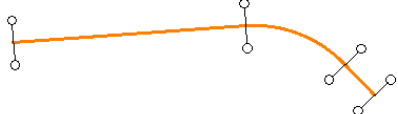
 <p><u>'Offset' style with 'Detailed Alignment Labelling'</u></p>	 <p><u>'Sectional' style with 'Sectional Labels Start and End'</u></p>
 <p><u>'Existing' style with 'Major and Minor Geometry'</u></p>	 <p><u>'Kerb Returns' style with 'Geometry Points – Symbols Only'</u></p>

2.8.3 Additional Alignment Labels

The following additional labels, some already included within the 'Label Sets', can be added to alignments as required:

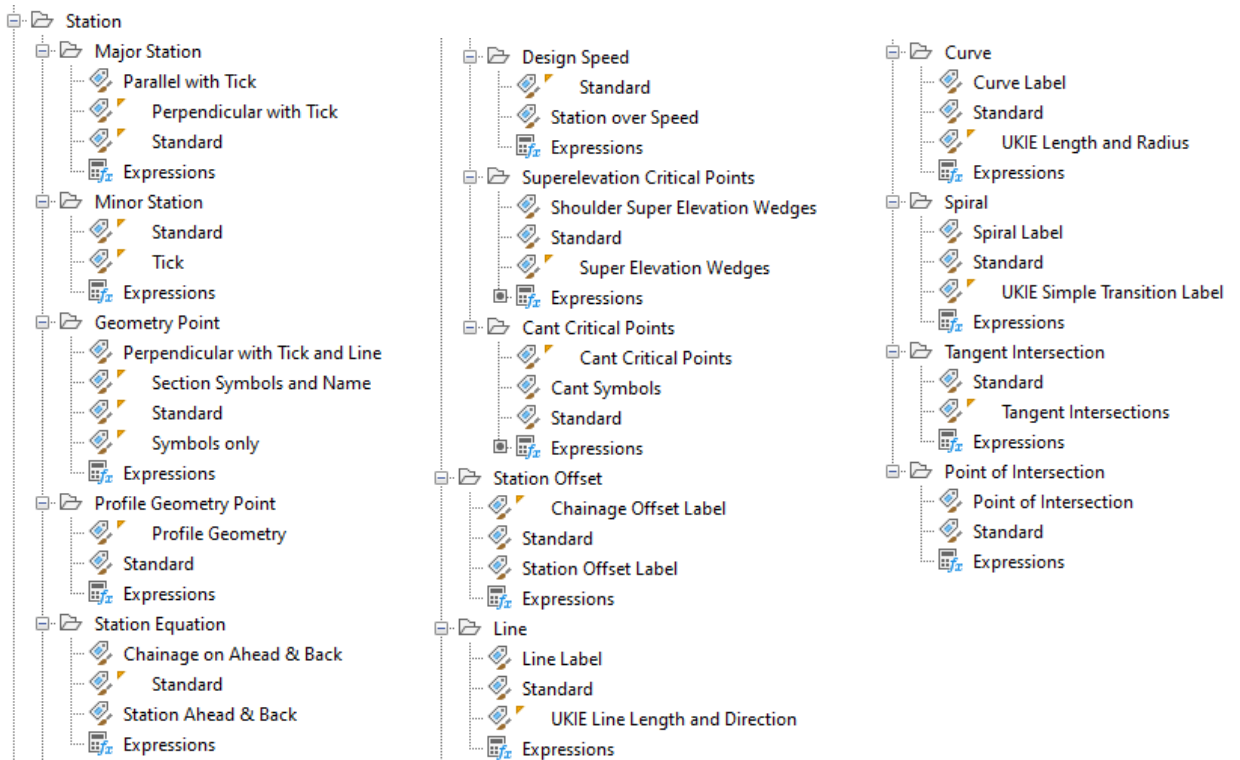

The 'UKIE' prefixed labels were added for the 2021 release of the UKIE kit.

2.8.4 Alignment Tables

Alignment tables can be generated based on the data obtained for either the Line, the Curve, the Transition (Spiral) or the Segment of the Alignment. An additional table is offered for each category over and above the standard variant offered.

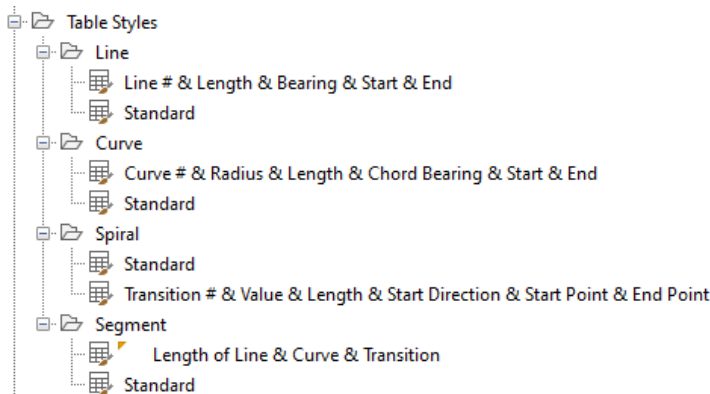

2.9 Profiles and Profile Views

2.9.1 Profile Styles

The default profile style is 'Design Style LWT'. This displays Straights in red and Sags\Crests in blue. Other styles are available, as shown below:

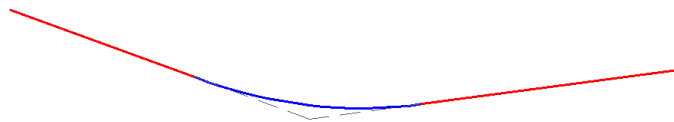
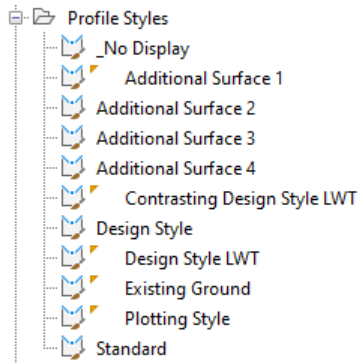

A profile using the 'Design Style LWT'

2.9.2 Profile Label Sets

Labeling a profile can be achieved during its creation by choosing a 'Profile Label Set'. The default is 'Longfall and Ordinates'. Label sets can be changed after creation by right-clicking the Profile and choosing 'Edit Labels' then 'Import label set..'

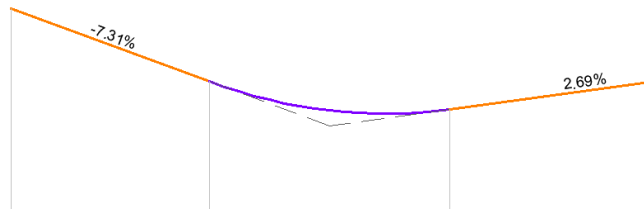

The 'Longfall and Ordinates' Label Set using the 'Contrasting Design Style LWT' profile style

The 'UKIE – Composite Labels' Label set has been designed to compliment the 'UKIE – Composite Band Set' ([see here](#)). Ordinates will match the band sample points in both position and colour. (as below)

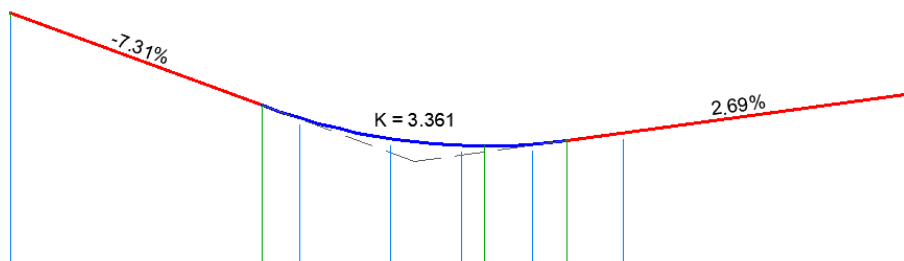

The 'UKIE – Composite Labels' Label Set

2.9.3 Additional Profile Labels

'Profile Label Sets' are constructed using many different 'Profile Labels'. The full list is shown below, and these can be added individually if required.

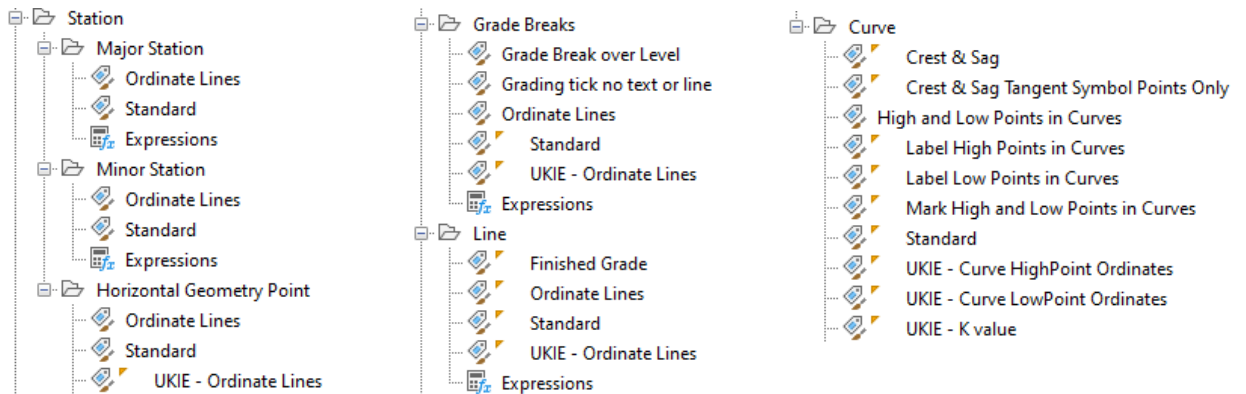

The 'UKIE' prefixed labels were added for the 2021 release of the UKIE kit.

2.9.4 Profile View Styles

By default, a new profile will be created with the '5x Exaggeration' Profile View Style. This creates a profile view that is exaggerated by 5 times on the Y-axis. Other 'Profile View Styles' are available as shown below.

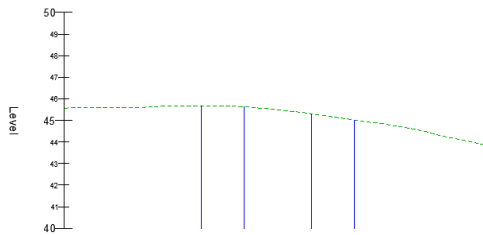
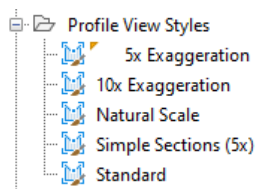

'Existing Ground' Profile Style on a '5x Exaggeration' Profile View

2.9.5 Band Sets

By default, when a new profile view is made it will be created with the '_Chainage and Existing Ground Levels' Band Set. This is a basic 'Band Set' that will display Chainage, Ground Levels and Horizontal Geometry.

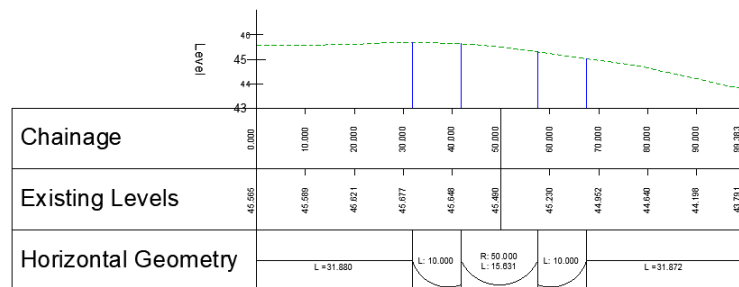
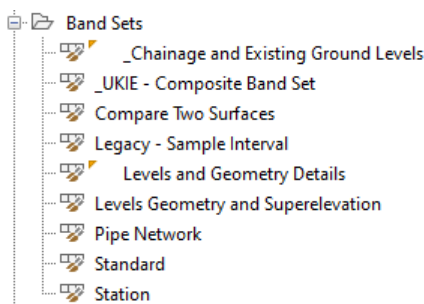

'Chainage and Existing Ground Levels' Band Set

When creating a ground profile, it is usual that a 'Design Profile' is yet to be created. Common workflow is to draw in the new 'Design Profile', then import a larger 'Band Set' that will reference data at the proposed heights. New for UKIE 2021 is the 'UKIE – Composite Band Set'.

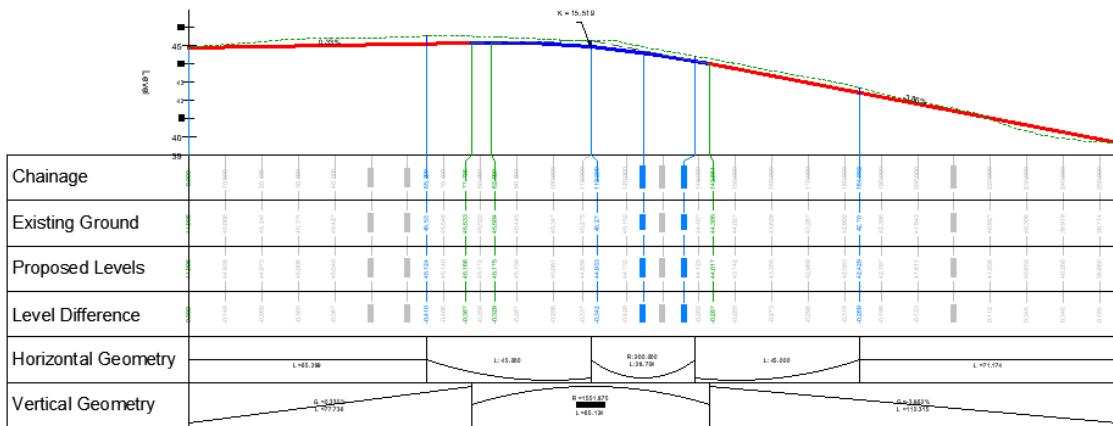

'UKIE – Composite Band Set'

It is important that following the import of any band set referencing proposed levels that you configure the 'Band Set' correctly, otherwise the data will be sampled from the 'Existing Ground' and the bands will be unreadable. To achieve this, you **MUST** assign the newly created design profile as 'Profile 1' inside 'Profile View Properties' on the 'Bands' tab.

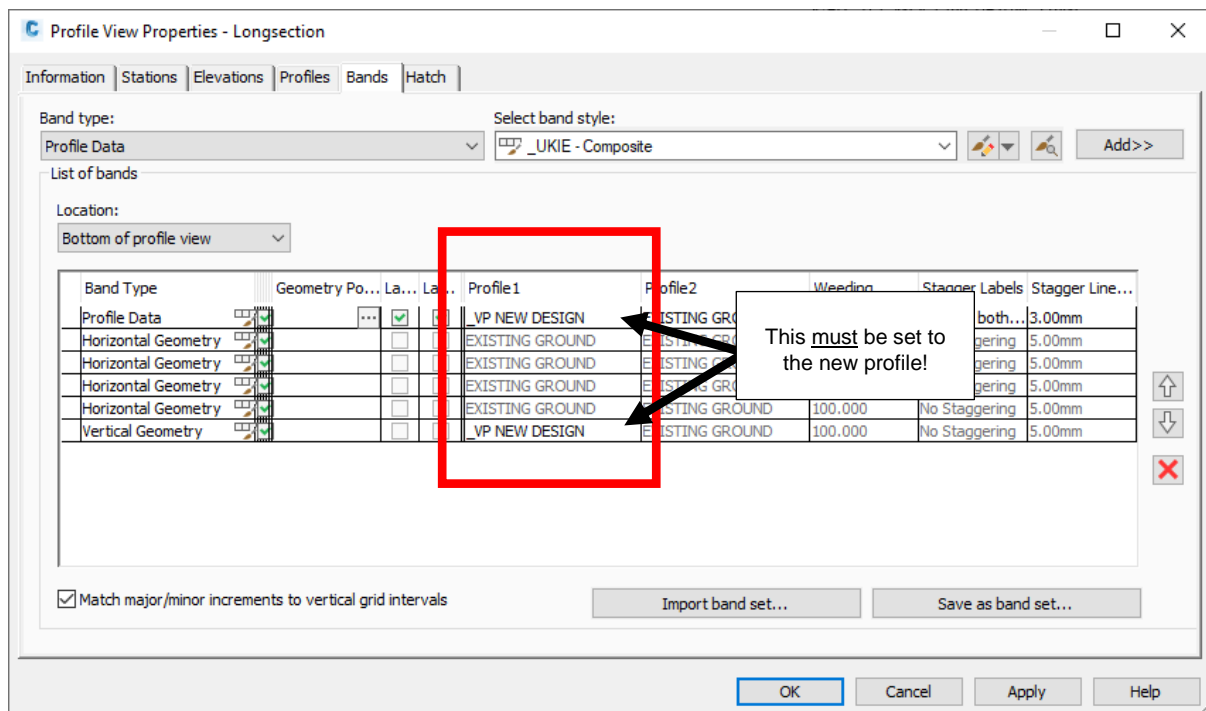

Setting 'Profile 1' to the newly created vertical design for the 'UKIE – Composite Band Set'

A matching Profile Label Set is available to match this band set. ([Profile Label Sets](#)).

2.9.6 Additional Band Styles

'Band Sets' are constructed using many different 'Band Styles'. The full list is shown below, and these can be added individually if required.

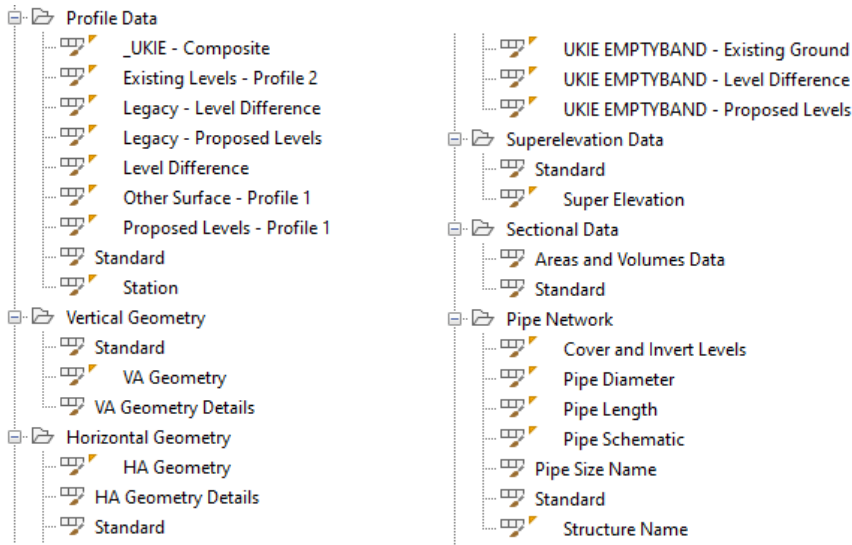

2.10 Sample Line Styles

2.10.1 Sample Line Styles and Sample Line Label Styles

When creating 'Sample Lines' the default style is 'Sample Lines' and the default labelling is 'UKIE Chainage'.



UKIE defaults when creating 'Sample Lines'

If chosen, the 'UKIE SLNum and Chainage' Label Style will include the Sample Line Number at the opposite end of each line.

2.11 Sections and Section Views

2.11.1 Section Styles

The default 'Section Style' when creating sections and multiple sections is '_Existing Ground'. It is recommended that you mix different styles to differentiate between multiple surface profiles and corridor profiles.

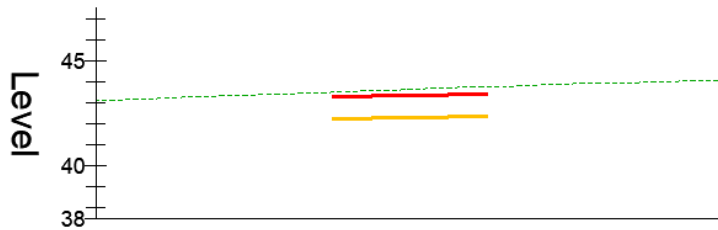
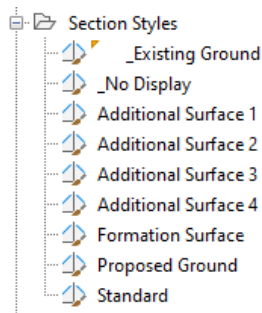

'Existing Ground', 'Proposed Ground' and 'Formation' styles used together

These styles can be set at the point of creating the 'Sample Line' or at the point of creating a 'Section View(s)'.

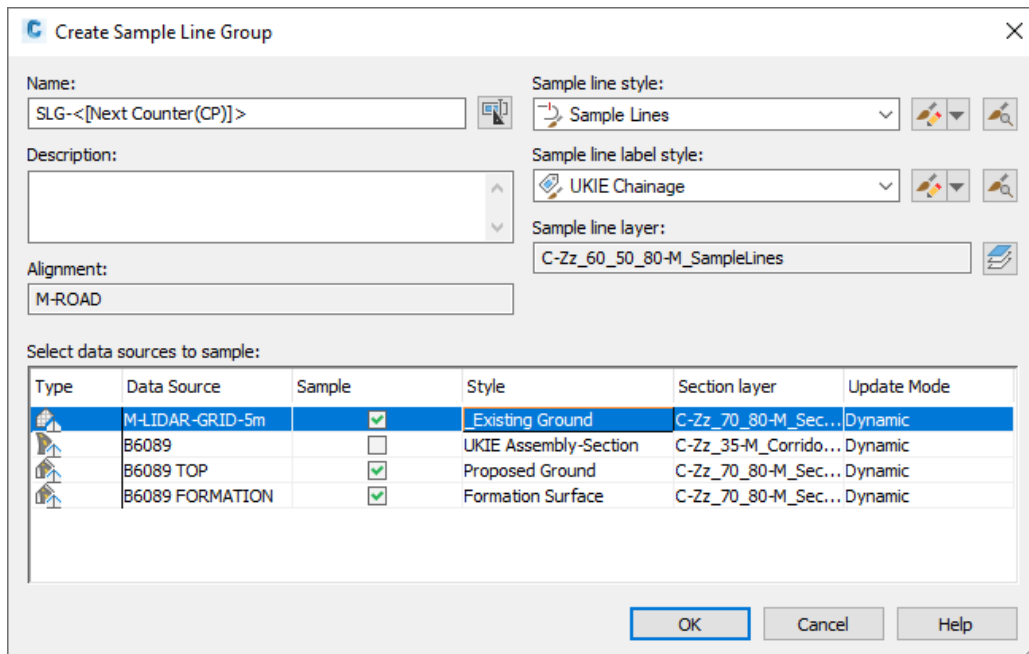

Selecting differing 'Section Styles' during the creation of a 'Sample Line Group'

2.11.2 Section Label Sets

Labelling a 'Section' can be achieved during its creation by choosing one of the 'Section Label Sets'. The default when creating 'Multiple Section Views' is set to '_No Labels'. This will ensure a clean and crisp set of sections out of the box.

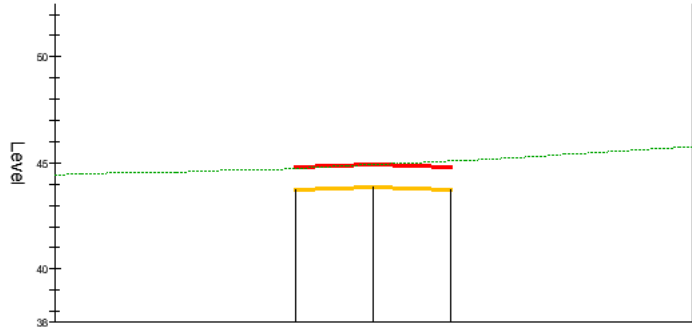
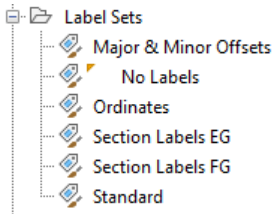

'Ordinate' Label Set added to the 'Formation' profile

Labels Sets can be added retrospectively by 'right-clicking' the section and choosing 'Edit Labels' followed by 'Import Label Set'. This can also be achieved for entire 'Section View Groups'.

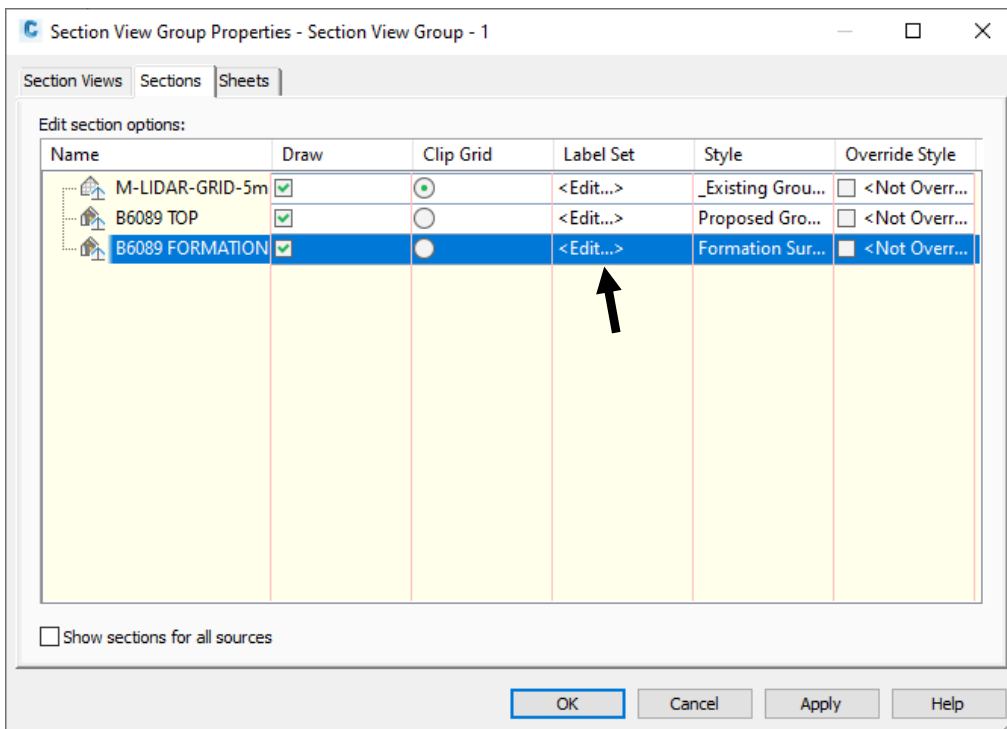

Changing 'Label Sets' on an entire 'Section View Group'

It is expected that these 'Label Sets' will be expanded on, in the next release of this Country Kit.

2.11.3 Additional Section Labels

Each 'Section Label Set' is constructed from the following 'Section Labels'. They can be added individually if required.

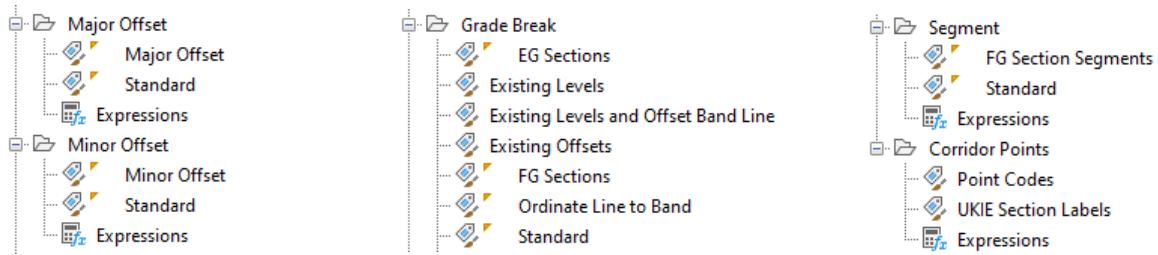

It is expected that these 'Section Labels' will be expanded on, in the next release of this Country Kit.

2.11.4 Section View Styles

The default 'Section View Style' is 'X Section Natural Scale'. This will deliver section views scaled without and exaggerated 'Y' axis. The additional styles are listed below:

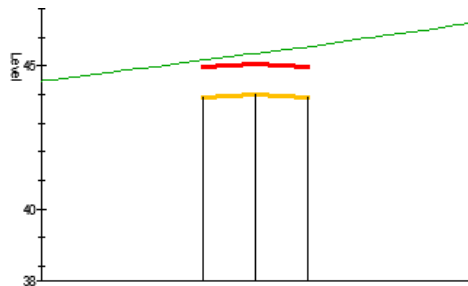
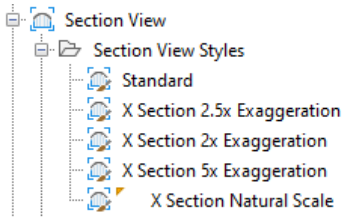

'X Section 2x Exaggeration'

2.11.5 Section View Band Sets

By default, when creating a 'Section View', the '_UKIE_Composite Band Set' is added to the bottom of the section(s).

This default was new in 2021. The older 'Band Sets' are prefixed with the word 'Legacy' and are still available.

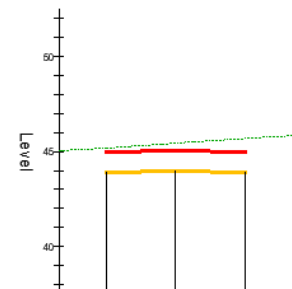
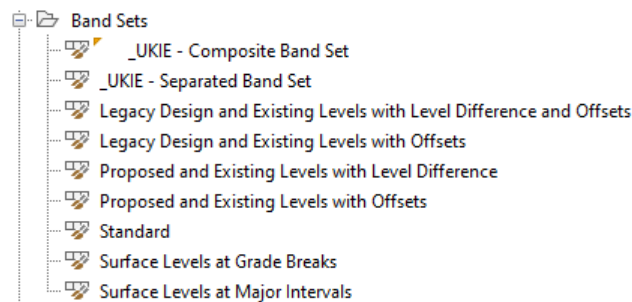

Proposed Levels		43.883		43.975		43.883
Offsets		-3.650		-0.000		-3.650
Existing Levels		45.191		45.427		45.668
Level Difference		-1.308		-1.452		-1.785

UKIE – Composite Band Set

The ‘_UKIE Composite Band Set’ contains bands for Proposed Levels, Offsets, Existing Levels and a Level Difference. It is important to ensure the correct profile is sampled otherwise the data shown in each band will be incorrect.

To ensure sampling is correctly assigned, ‘Surface 1’ must be assigned to the Proposed Surface and ‘Surface 2’ must be assigned to the Existing Ground surface. This can be achieved during creation of the ‘Section View(s)’ or can be edited on the ‘Section View Properties’ sheet or through the ‘View Group Properties’ dialogue box.

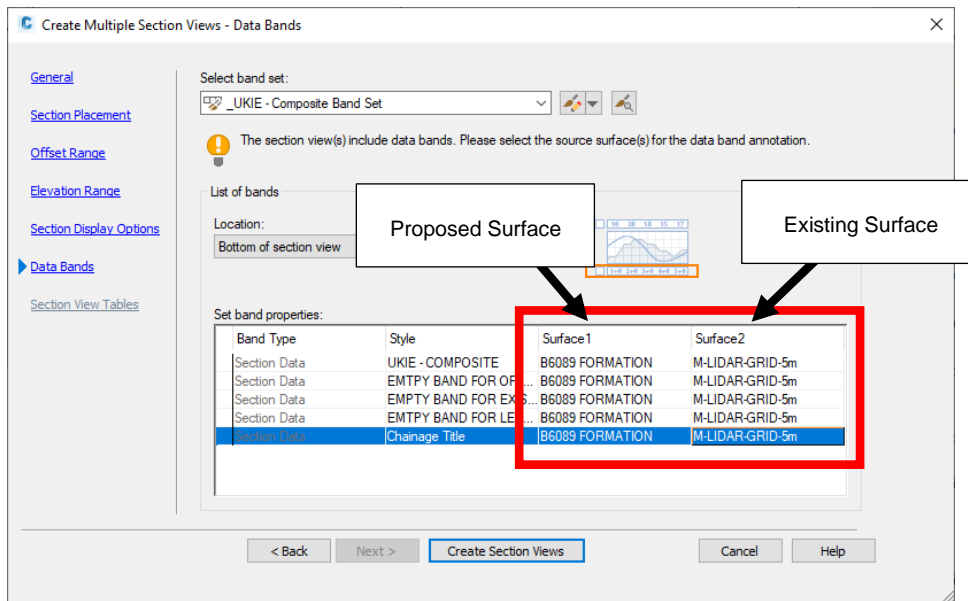

Declaring the sampled bands during Multiple Section View placement

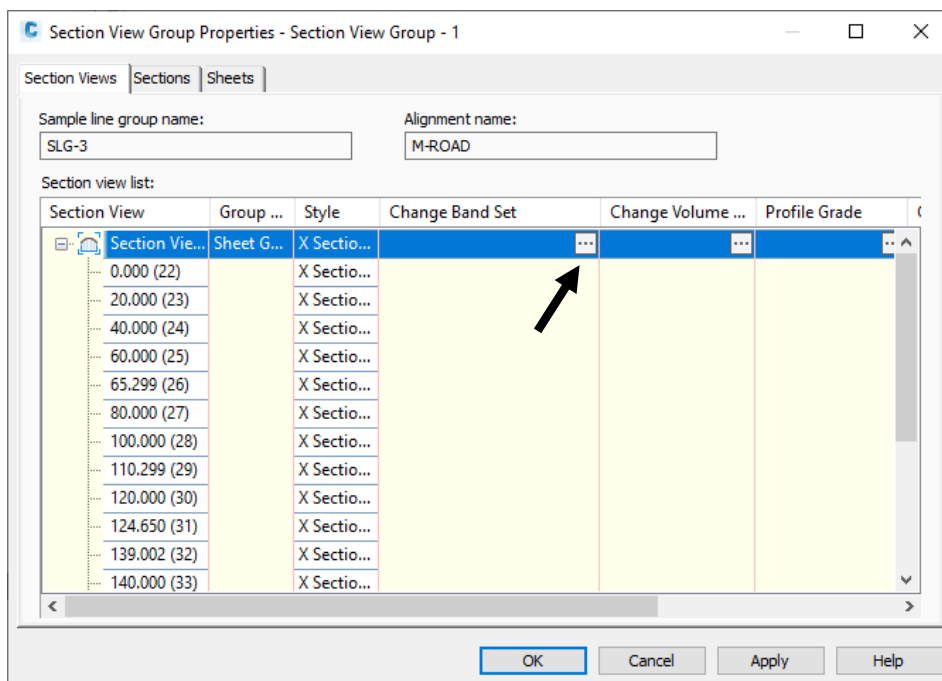

Editing the band sampling through ‘Section View Group Properties’

2.11.6 Additional Band Styles

The following individual band styles are offered:

- | | |
|--|---|
| <ul style="list-style-type: none"> Section Data _Section Master - Levels and Offsets _Section Master - Levels Differences Offsets Chainage Title EMPTY BAND FOR EXISTING LEVELS EMPTY BAND FOR LEVEL DIFFERENCE EMPTY BAND FOR OFFSETS Existing Levels at Grade Breaks | <ul style="list-style-type: none"> Level Difference Offsets Proposed Levels at Grade Breaks Standard Surface Levels at Major Interval (Section 1) UKIE - COMPOSITE UKIE - SPLIT - LINES UKIE - SPLIT - TEXT |
|--|---|

Some band styles, such as the three 'UKIE' band styles, require additional empty bands adding in order to annotate the data presented. These empty styles are prefixed with 'EMPTY BAND..'

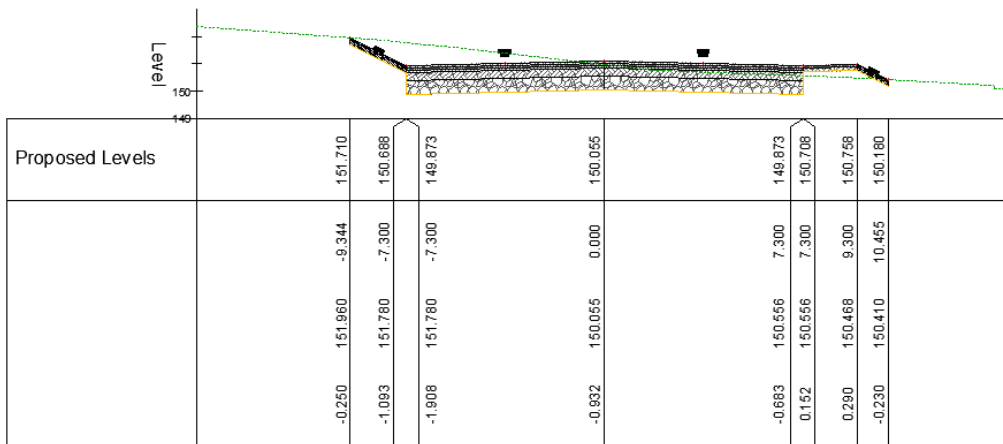

'UKIE-SPLIT-LINES' and 'UKIE-SPLIT-TEXT' without the empty band sets added

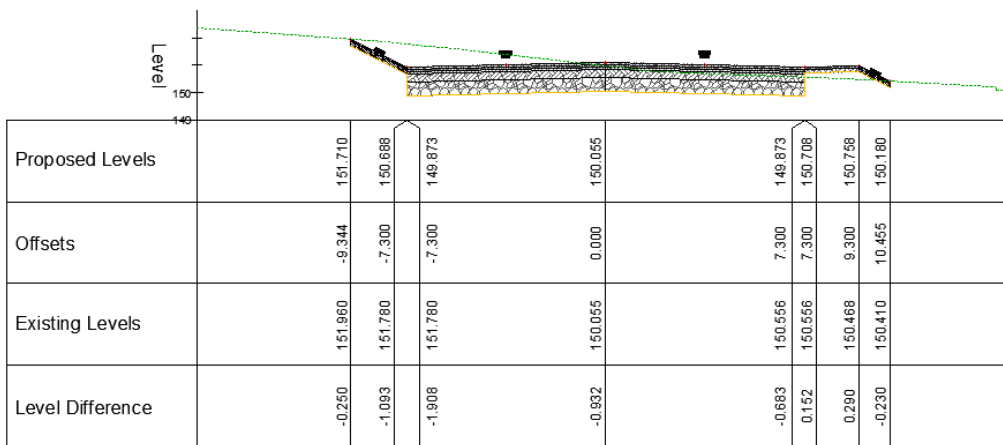

'UKIE-SPLIT-LINES' and 'UKIE-SPLIT-TEXT' with the empty band sets added

3.0 Toolbox Utilities

In addition to standard reports and utilities shipped with Civil 3D, the UKIE Country Kit includes reports specifically for the UK and Ireland and some useful utilities. These can be accessed under the 'UK and Ireland Reports' section on the 'Toolbox' tab in the 'Toolspace'.

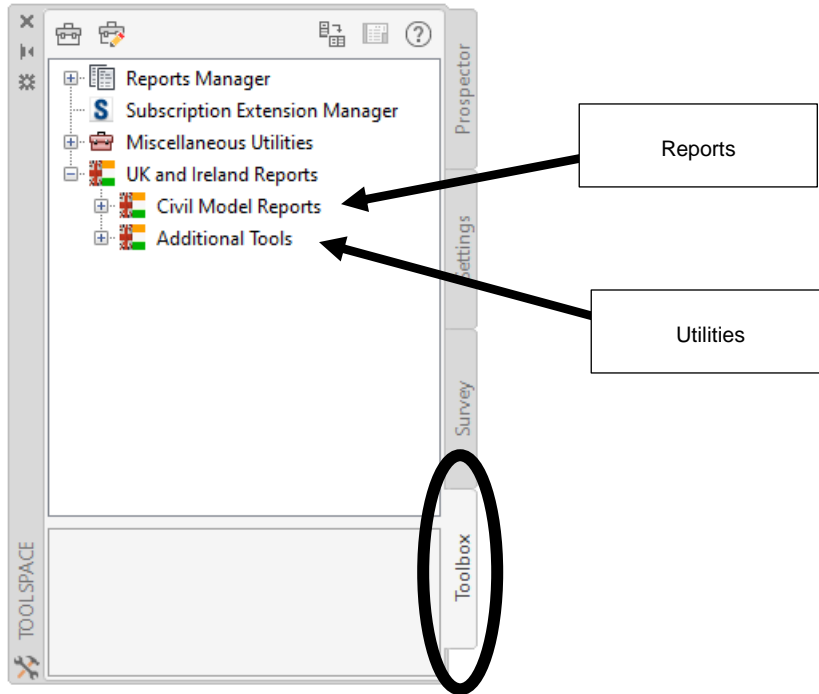

3.1 Civil Model Reports (Reports)

To run the desired report, right click the report name and choose 'Execute'.

On the whole, the reports in this section can be saved in multiple formats. The default format is .html, but this can be changed to either .doc, .pdf, .txt or .xls.

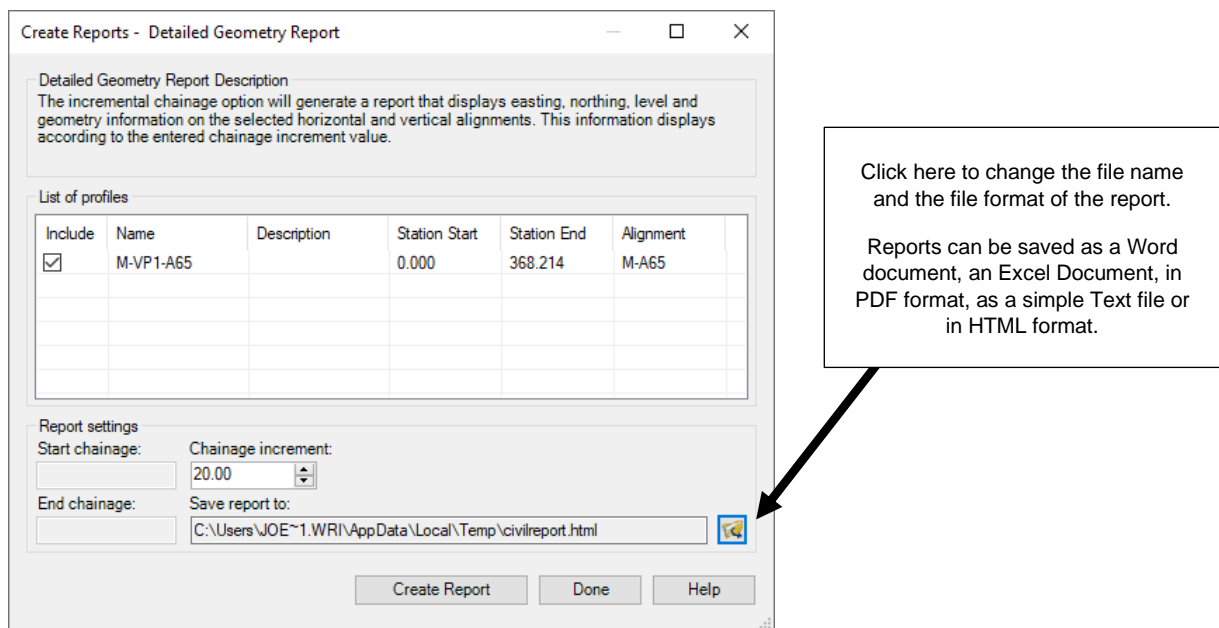

All reports will use the terminologies of the language variant of Civil 3D that has been installed.

To get the correct technical references in the report fields you should be using the 'British English' variant of Civil 3D.

If you use the 'English' variant of Civil 3D you will find that some tables reference American terminologies such as 'Station' rather than 'Chainage'.

3.1.1 Feature Lines

This report displays the X, Y and Z at point locations for the selected Feature Lines.

The output for this report is limited to .CSV format, as below.

Top Of Bank		
X	Y	Z
252895.168	655159.003	145.305
252854.349	655173.661	147.153
252797.449	655183.373	148.709
252805.401	655254.896	148.709

Note: The feature line must have a name. Unnamed feature lines cannot be used in this report.

3.1.2 Alignments

Three alignment reports are available.

Alignment Incremental Chainage Report

This report tabularizes Northing and Easting at specified chainage intervals. The straight (tangent) direction of the alignment is also included.

Chainage	Northing	Easting	Straight Direction
0.000	655,111.636m	252,799.360m	N24°49'09.00"E
20.000	655,129.789m	252,807.755m	N24°49'09.00"E
40.000	655,147.942m	252,816.150m	N24°49'09.00"E
60.000	655,166.284m	252,824.110m	N20°52'19.52"E
80.000	655,185.296m	252,830.290m	N15°08'33.04"E
100.000	655,204.831m	252,834.541m	N9°24'46.56"E
120.000	655,224.692m	252,836.821m	N3°41'00.08"E
140.000	655,244.682m	252,837.107m	N2°02'46.40"W
160.000	655,264.600m	252,835.395m	N7°46'32.88"W
180.000	655,284.248m	252,831.704m	N13°30'19.36"W
200.000	655,303.694m	252,827.031m	N13°30'36.30"W
220.000	655,323.141m	252,822.359m	N13°30'36.30"W
240.000	655,340.628m	252,813.500m	N48°15'39.33"W
260.000	655,348.211m	252,795.268m	N75°47'24.88"W
275.210	655,351.944m	252,780.523m	N75°47'24.88"W

Alignment PI Chainage Report

This report lists each Point of Intersection (PI) along the alignment. This represents the 'straights' of the alignment and does not display any horizontal curve information.

IP Chainage	Northing	Easting	Distance	Direction
0.000	655,111.636m	252,799.360m		
			115.731m	N24°49'09.00"E
115.731	655,216.678m	252,847.938m		
			129.434m	N13°30'36.30"W
239.941	655,342.530m	252,817.701m		
			38.351m	N75°47'24.88"W
275.210	655,351.944m	252,780.523m		

Alignment Geometry Checks

Running this report against an alignment with a 'Design Check' or a 'Design Criteria' will display each segment at the declared design speed. It will highlight when conditions do not meet the design standards.

1 Straight

Start Chainage: 0.000
 End Chainage: 46.222
 Length: 46.222m
 Design Speed: 60
 Design Checks:

2 Circular Curve

Start Chainage: 46.222
 End Chainage: 180.016
 Radius: 200.000m
 Design Speed: 60
 Design Criteria:
 Minimum Radius: 510.00 Violated
 Design Checks:

3 Straight

Start Chainage: 180.016
 End Chainage: 224.601
 Length: 44.584m
 Design Speed: 60
 Design Checks:

3.1.3 Profiles

Four 'Profile' reports are available.

Profile PV Curve Report

This vertical curve report displays information for crest and sag vertical curves. The data generated is shown below:

Vertical Curve Information:(crest curve)				Vertical Curve Information:(sag curve)			
PVC Chainage:	103.314	Level:	154.589m	PVC Chainage:	177.125	Level:	152.050m
VIP Station:	126.575	Level:	156.401m	VIP Station:	197.956	Level:	150.257m
PVT Chainage:	149.837	Level:	154.399m	PVT Chainage:	218.787	Level:	151.401m
High Point:	125.413	Level:	155.450m	Low Point:	202.561	Level:	150.955m
Gradient In:	7.788%	Gradient Out:	-8.607%	Gradient In:	-8.607%	Gradient Out:	5.491%
Change:	16.395%	K:	2.838m	Change:	14.098%	K:	2.955m
Curve Length:	46.523m	Curve Radius	283.757m	Curve Length:	41.662m	Curve Radius	295.509m
Overtaking Distance:	38.243m	Stopping Distance:	44.549m	Headlight Distance:	39.924m		

Profile PVI Curve Report

This report lists the chainage, level and gradient out for each PVI. The data included is shown below:

VIP	Chainage	Gradient Out	Curve Length
0.00	0.000	3.115%	
1.00	82.337	1.987%	11.277m
	Vertical Curve Information:(crest curve)		
	PVC Chainage:	76.699	Level: 148.932m
	VIP Station:	82.337	Level: 149.108m
	PVT Chainage:	87.976	Level: 149.220m
	High Point:	87.976	Level: 149.220m
	Gradient In:	3.115%	Gradient Out: 1.987%
	Change:	1.128%	K: 9.99999999999879
	Curve Length:	11.277m	
	Overtaking Distance:	234.171m	Stopping Distance: 315.746m
2.00	197.293	3.988%	18.009m
	Vertical Curve Information:(sag curve)		
	PVC Chainage:	188.288	Level: 151.213m
	VIP Station:	197.293	Level: 151.392m
	PVT Chainage:	206.297	Level: 151.751m
	Low Point:	188.288	Level: 151.213m
	Gradient In:	1.987%	Gradient Out: 3.988%
	Change:	2.001%	K: 8.9999999999988
	Curve Length:	18.009m	
	Headlight Distance:	853.214m	
3.00	275.210		

Profile Chainage Inc Report

This report displays a list of levels at critical geometry points including at crest and sag curve points. It also shows the percent grade from the previous chainage value.

Chainage	Level	Gradient Per cent (%)	Location
0.000	146.543m		VIP
20.000	147.166m	3.115%	
40.000	147.789m	3.115%	
60.000	148.412m	3.115%	
76.699	148.932m	3.115%	PVC
80.000	149.029m	2.950%	
82.337	149.092m	2.668%	Crest
87.976	149.220m	2.269%	PVT
100.000	149.459m	1.987%	
120.000	149.856m	1.987%	
140.000	150.253m	1.987%	
160.000	150.651m	1.987%	
180.000	151.048m	1.987%	
188.288	151.213m	1.987%	PVC
197.293	151.437m	2.487%	Sag
200.000	151.522m	3.138%	
206.297	151.751m	3.638%	PVT
220.000	152.297m	3.988%	
240.000	153.095m	3.988%	
260.000	153.893m	3.988%	
275.210	154.499m	3.988%	VIP

Profile Geometry Checks

Based on the design speed along with the declared 'Design Checks' and 'Design Criteria' assigned to the profile, this report displays data as shown below. Failed design checks are annotated with 'Violated'.

1 Crest Curve:Parabolic

PVC Chainage:	71.060	
VIP Station:	82.337	
PVT Chainage:	93.614	
Gradient in(%):	3.115%	
Gradient out(%):	1.987%	
Curve Length:	22.554m	
K:	20.00	
Design Speed:	60	
<u>Design Criteria:</u>		
Minimum K for Stopping Sight Distance:		
Minimum K for Overtaking Sight Distance:		
<u>Design Checks:</u>		
Desirable Minimum Crest K Value		Cleared
One Step below Desirable Min Crest K Value		Cleared

2 Sag Curve:Parabolic

PVC Chainage:	188.288	
VIP Station:	197.293	
PVT Chainage:	206.297	
Gradient in(%):	1.987%	
Gradient out(%):	3.988%	
Curve Length:	18.009m	
K:	9.00	
Design Speed:	60	
<u>Design Criteria:</u>		
Minimum K for Headlight Sight Distance:		
<u>Design Checks:</u>		
Desirable Minimum Sag K Value		Violated

Combined Geometry

The 'Combined Geometry Report' is a UK specific report that shows the Easting and Northing of points at declared chainage and geometry change points. It also lists the level, the referenced critical geometry and a bearing, as well the radius of any horizontal curve.

This is probably the most useful 'Alignment\Profile' report as it combines information from both the horizontal and vertical components. It is very useful for setting out purposes.

Point	Chainage	Easting	Northing	Level	Cumulative Distance	Reference	Bearing	Radius
1	0.000	252799.36m	655111.636m	146.543m	0m	Begin of Alignment, VPI	24°49'09.0"	Infinity
2	20.000	252807.755m	655129.789m	147.166m	20m		24°49'09.0"	Infinity
3	40.000	252816.15m	655147.942m	147.789m	40m		24°49'09.0"	Infinity
4	46.222	252818.762m	655153.589m	147.983m	46.222m	Line - Curve	24°49'09.0"	Infinity
5	60.000	252824.11m	655166.284m	148.412m	60m		20°52'19.52"	200m
6	71.060	252827.763m	655176.722m	148.756m	71.06m	Vertical TP	17°42'12.67"	200m
7	80.000	252830.29m	655185.296m	149.015m	80m		15°08'33.3"	200m
8	82.337	252830.887m	655187.556m	149.076m	82.337m	VPI	14°28'22.52"	200m
9	93.614	252833.397m	655198.549m	149.332m	93.614m	Vertical TP, High Point	11°14'32.37"	200m
10	100.000	252834.541m	655204.831m	149.459m	100m		9°24'46.55"	200m
11	113.119	252836.261m	655217.834m	149.719m	113.119m		5°39'16.35"	200m
12	120.000	252836.821m	655224.692m	149.856m	120m		3°41'00.7"	200m
13	140.000	252837.107m	655244.682m	150.253m	140m		357°57'13.59"	200m
14	160.000	252835.395m	655264.6m	150.651m	160m		352°13'27.11"	200m
15	180.000	252831.704m	655284.248m	151.048m	180m		346°29'40.63"	200m
16	180.016	252831.7m	655284.264m	151.049m	180.016m	Curve - Line	346°29'23.70"	200m
17	188.288	252829.768m	655292.306m	151.213m	188.288m	Vertical TP, Low Point	346°29'23.70"	Infinity
18	197.293	252827.664m	655301.062m	151.437m	197.293m	VPI	346°29'23.70"	Infinity
19	200.000	252827.031m	655303.694m	151.522m	200m		346°29'23.70"	Infinity
20	206.297	252825.56m	655309.817m	151.751m	206.297m	Vertical TP	346°29'23.70"	Infinity
21	220.000	252822.359m	655323.141m	152.297m	220m		346°29'23.70"	Infinity
22	224.601	252821.284m	655327.614m	152.481m	224.601m	Line - Curve	346°29'23.70"	Infinity
23	238.400	252814.66m	655339.526m	153.031m	238.4m		315°20'59.41"	25.39m
24	240.000	252813.5m	655340.628m	153.095m	240m		311°44'20.67"	25.39m
25	252.199	252802.83m	655346.296m	153.581m	252.199m	Curve - Line	284°12'35.11"	25.39m
26	260.000	252795.268m	655348.211m	153.893m	260m		284°12'35.11"	Infinity
27	275.210	252780.523m	655351.944m	154.499m	275.21m	End of Alignment	284°12'35.11"	Infinity
28	275.210	252780.523m	655351.944m	154.499m	275.21m	VPI	284°12'35.11"	Infinity

3.1.4 Corridor

Five 'Corridor' reports are available. All require at least one corridor in the drawing, and many rely on a sample line group to decide sample points.

Corridor Setting Out Report – Slope and Offsets

This useful report generates a stake out table for setting out. It can also display a handy graphic, visually showing the corridor at the sampled chainage.

This report will only run if you have a 'Sample Line Group' assigned to the alignment upon which the corridor is based.

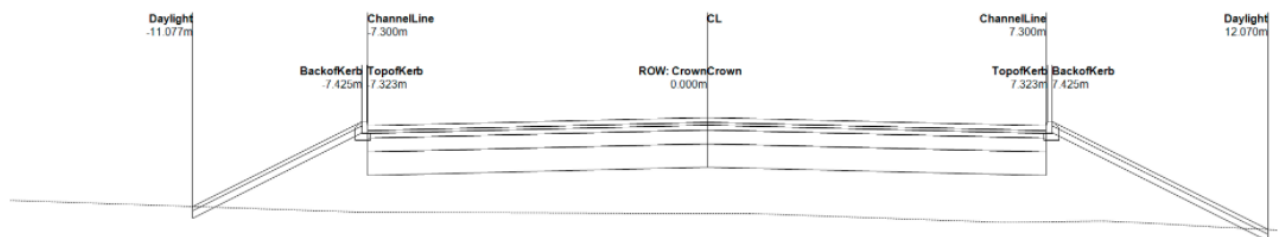
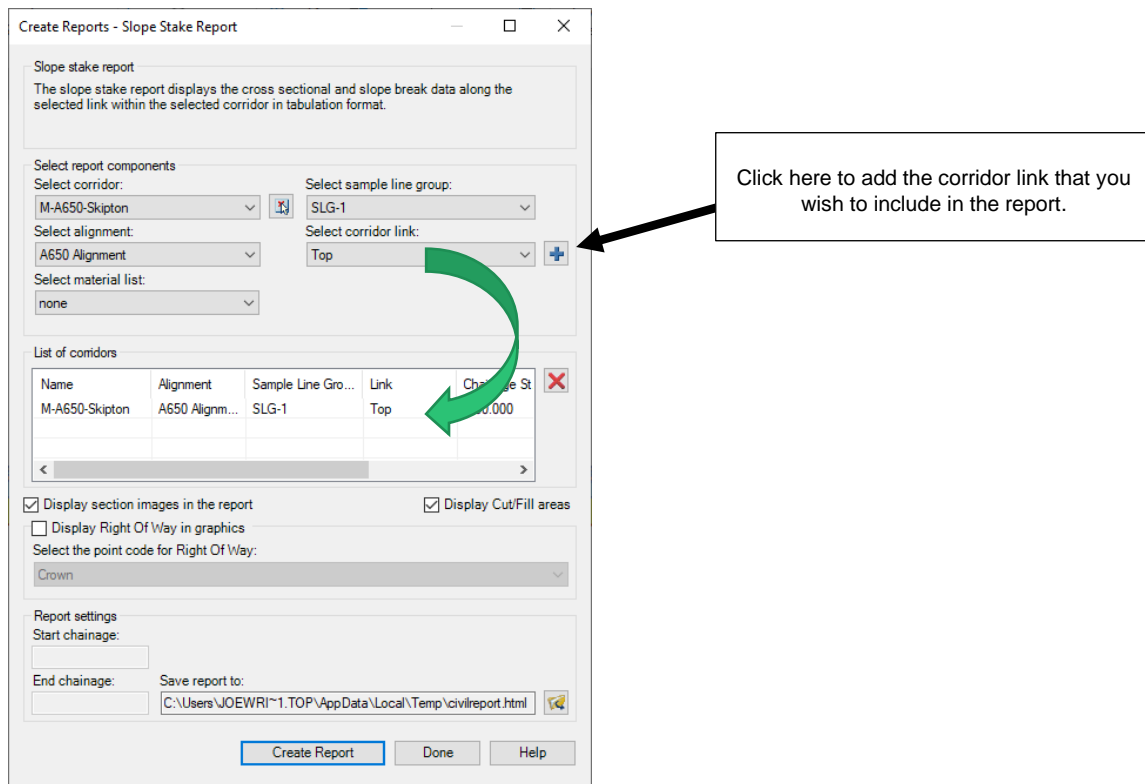

A650 Alignment

Chainage: 40.000

F1.83	Daylight	BackofKerb	TopofKerb	ChannelLine	CL	Crown	ChannelLine	TopofKerb	BackofKerb	Daylight	F2.32
@3.65	-11.077m	-7.425m	-7.323m	-7.300m	0.000m	0.000m	7.300m	7.323m	7.425m	12.070m	@4.64
1:-0.50	145.881m	147.707m	147.707m	147.607m	147.789m	147.789m	147.607m	147.707m	147.707m	145.384m	1:-0.50
		1:-0.50	0.00 %	1:4.35		-2.50 %	1:4.35	0.00 %	1:-0.50		

Cross Section Report – Surfaces

This report requires a 'Corridor Surface', and a 'Sample Line Group' to generate setting out tables.

Offsets will be calculated from point codes declared in the assembly.

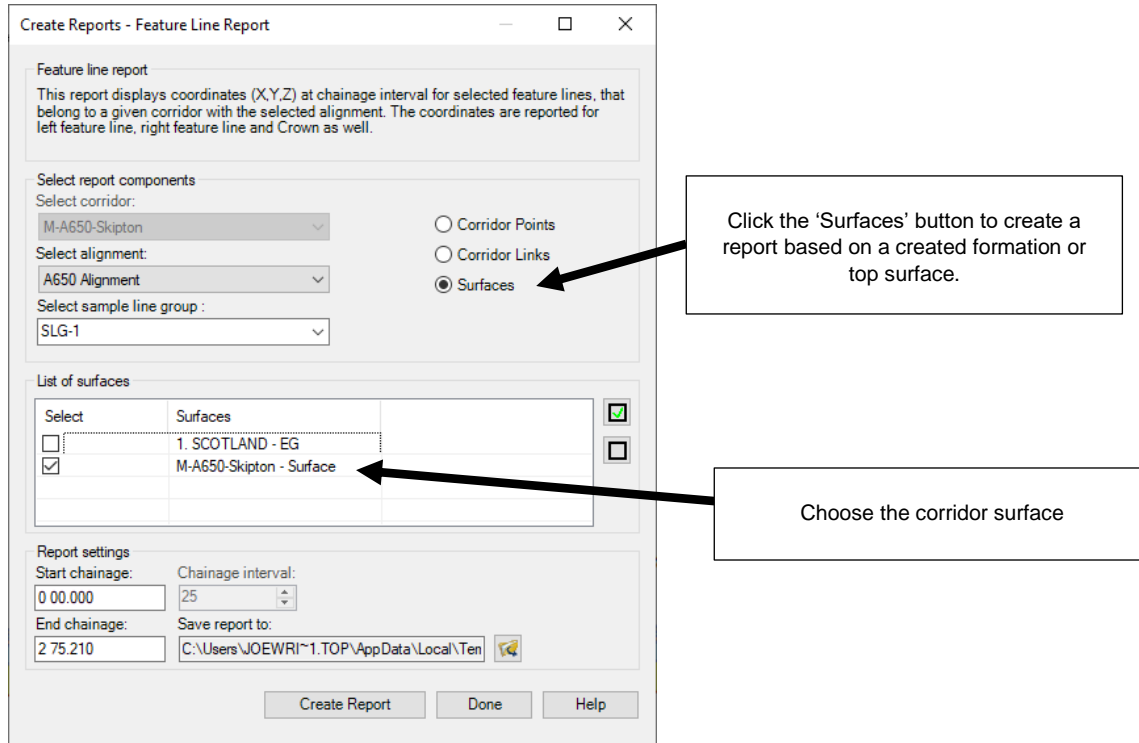

Chainage: 40.000

Offset	-11.077m	-7.575m	-7.575m	-7.300m	0.000m	7.300m	7.575m	7.575m	12.070m
Level	145.631m	147.381m	147.302m	147.302m	146.724m	146.542m	147.302m	147.381m	145.134m
Easting	252,806.096	252,809.274	252,809.275	252,809.524	252,816.150	252,822.776	252,823.025	252,823.025	252,827.105
Northing	655,152.591	655,151.122	655,151.122	655,151.006	655,147.942	655,144.878	655,144.762	655,144.762	655,142.875

A650 Alignment

Chainage: 46.222

Offset	-11.133m	-7.575m	-7.575m	-7.300m	0.000m	7.300m	7.575m	7.575m	12.292m
Level	145.796m	147.575m	147.495m	147.495m	146.918m	146.735m	147.495m	147.575m	145.217m
Easting	252,808.657	252,811.886	252,811.886	252,812.136	252,818.762	252,825.387	252,825.637	252,825.637	252,829.918
Northing	655,158.262	655,156.769	655,156.769	655,156.654	655,153.589	655,150.525	655,150.410	655,150.410	655,148.430

A650 Alignment

Chainage: 60.000

Offset	-10.205m	-7.575m	-7.575m	-7.300m	0.000m	7.300m	7.575m	7.575m	11.531m
Level	146.689m	148.004m	147.924m	147.924m	147.347m	147.164m	147.924m	148.004m	146.027m
Easting	252,814.575	252,817.032	252,817.032	252,817.289	252,824.110	252,830.931	252,831.188	252,831.188	252,834.884
Northing	655,169.920	655,168.983	655,168.983	655,168.885	655,166.284	655,163.683	655,163.585	655,163.585	655,162.176

A650 Alignment

Corridor Limits Report

This report shows the setting out points for the Daylight components of any cut and fill sub-assemblies included in the assembly.

SL Name	Chainage	Left Daylight Offset	X Left	Y Left	Z Left	Right Daylight Offset	X Right	Y Right	Z Right
0.000	0.000	-7.483	252,792.567	655,114.778	146.431	7.440	252,806.112	655,108.513	146.453
20.000	20.000	-9.578	252,799.061	655,133.810	146.007	10.128	252,816.947	655,125.538	145.732
40.000	40.000	-11.077	252,806.096	655,152.591	145.881	12.070	252,827.105	655,142.875	145.384
46.222	46.222	-11.133	252,808.657	655,158.262	146.046	12.292	252,829.918	655,148.430	145.467
60.000	60.000	-10.205	252,814.575	655,169.920	146.939	11.531	252,834.884	655,162.176	146.277
80.000	80.000	-7.929	252,822.636	655,187.367	148.680	9.117	252,839.090	655,182.915	148.087
100.000	100.000	-9.426	252,825.242	655,206.372	150.377	8.225	252,842.656	655,203.485	149.776
113.119	113.119	-11.012	252,825.303	655,218.919	151.430	9.193	252,845.409	655,216.929	150.521
120.000	120.000	-12.482	252,824.365	655,225.494	152.302	10.113	252,846.913	655,224.042	151.118
140.000	140.000	-14.969	252,822.147	655,244.147	153.943	10.936	252,848.035	655,245.072	151.926
160.000	160.000	-18.075	252,817.487	655,262.154	155.893	11.652	252,846.940	655,266.176	152.682
180.000	180.000	-16.876	252,815.295	655,280.307	155.691	12.550	252,843.907	655,287.179	153.528
180.016	180.016	-16.874	252,815.293	655,280.322	155.690	12.552	252,843.904	655,287.196	153.529
200.000	200.000	-12.832	252,814.555	655,300.697	154.143	11.266	252,837.986	655,306.326	153.360
220.000	220.000	-7.640	252,814.930	655,321.356	152.323	7.800	252,829.944	655,324.963	152.027
224.601	224.601	-7.635	252,813.860	655,325.830	152.293	8.393	252,829.445	655,329.575	151.914
238.400	238.400	-8.722	252,808.455	655,333.397	152.300	7.768	252,820.186	655,344.985	152.777
240.000	240.000	-8.300	252,807.975	655,334.435	152.575	7.616	252,818.570	655,346.311	152.917
252.199	252.199	-8.265	252,800.801	655,338.283	153.919	8.341	252,804.877	655,354.381	153.957
260.000	260.000	-8.802	252,793.107	655,339.678	154.499	8.683	252,797.399	655,356.628	154.439
275.210	275.210	-8.027	252,778.552	655,344.162	154.718	7.724	252,782.419	655,359.432	154.267

Lane Slope Report

Slopes report as 0%! This report is currently unusable.

Corridor Setting Out Report – Feature Lines Points

Whilst limited to fixed chainage intervals, this report will create setting out data of the selected code points in a corridor.

CHAINAGE 50.000

POINT	X	Y	Z	OFFSET	STRING CUT
1	252,810.188	655,161.486	146.199	-11.062m	Daylight
2	252,813.518	655,160.022	148.018	-7.425m	BackofKerb
3	252,813.633	655,159.972	147.918	-7.300m	ChannelLine
4	252,820.315	655,157.033	148.100	0.000m	Crown
5	252,826.997	655,154.094	147.918	7.300m	ChannelLine
6	252,827.112	655,154.044	148.018	7.425m	BackofKerb
7	252,831.378	655,152.168	145.688	12.085m	Daylight

CHAINAGE 75.000

POINT	X	Y	Z	OFFSET	STRING CUT
1	252,820.773	655,182.913	148.253	-8.504m	Daylight
2	252,821.807	655,182.605	148.793	-7.425m	BackofKerb
3	252,821.927	655,182.569	148.693	-7.300m	ChannelLine
4	252,828.924	655,180.487	148.875	0.000m	Crown
5	252,835.920	655,178.404	148.693	7.300m	ChannelLine
6	252,836.040	655,178.369	148.793	7.425m	BackofKerb
7	252,838.336	655,177.685	147.595	9.820m	Daylight

CHAINAGE 100.000

POINT	X	Y	Z	OFFSET	STRING CUT
1	252,825.242	655,206.372	150.377	-9.426m	Daylight
2	252,827.216	655,206.045	149.376	-7.425m	BackofKerb
3	252,827.340	655,206.025	149.276	-7.300m	ChannelLine
4	252,834.541	655,204.831	149.459	0.000m	Crown
5	252,841.743	655,203.637	149.276	7.300m	ChannelLine
6	252,841.866	655,203.616	149.376	7.425m	BackofKerb
7	252,842.656	655,203.485	149.776	8.225m	Daylight

3.1.5 Points

This report will document selected points and list their level and offset position from the chosen Alignment.

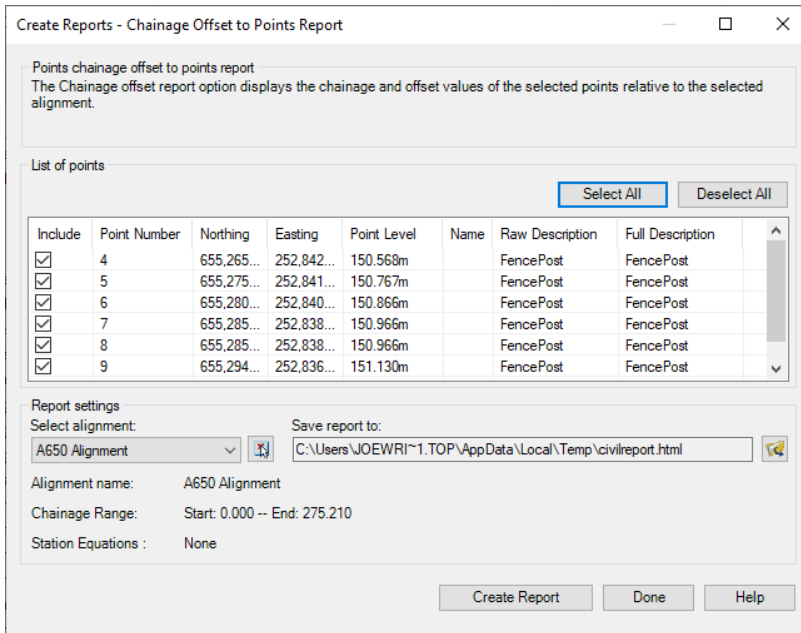

Point	Chainage	Offset	Level	Description
4	160.000	7.425m	150.568m	(FencePost)FencePost
5	170.000	7.425m	150.767m	(FencePost)FencePost
6	175.000	7.425m	150.866m	(FencePost)FencePost
7	180.000	7.425m	150.966m	(FencePost)FencePost
8	180.016	7.425m	150.966m	(FencePost)FencePost
9	188.288	7.425m	151.130m	(FencePost)FencePost
10	200.000	7.425m	151.439m	(FencePost)FencePost

3.2 Additional Tools (Utilities)

Thirteen 'Additional Tools' are available on the Toolbox.

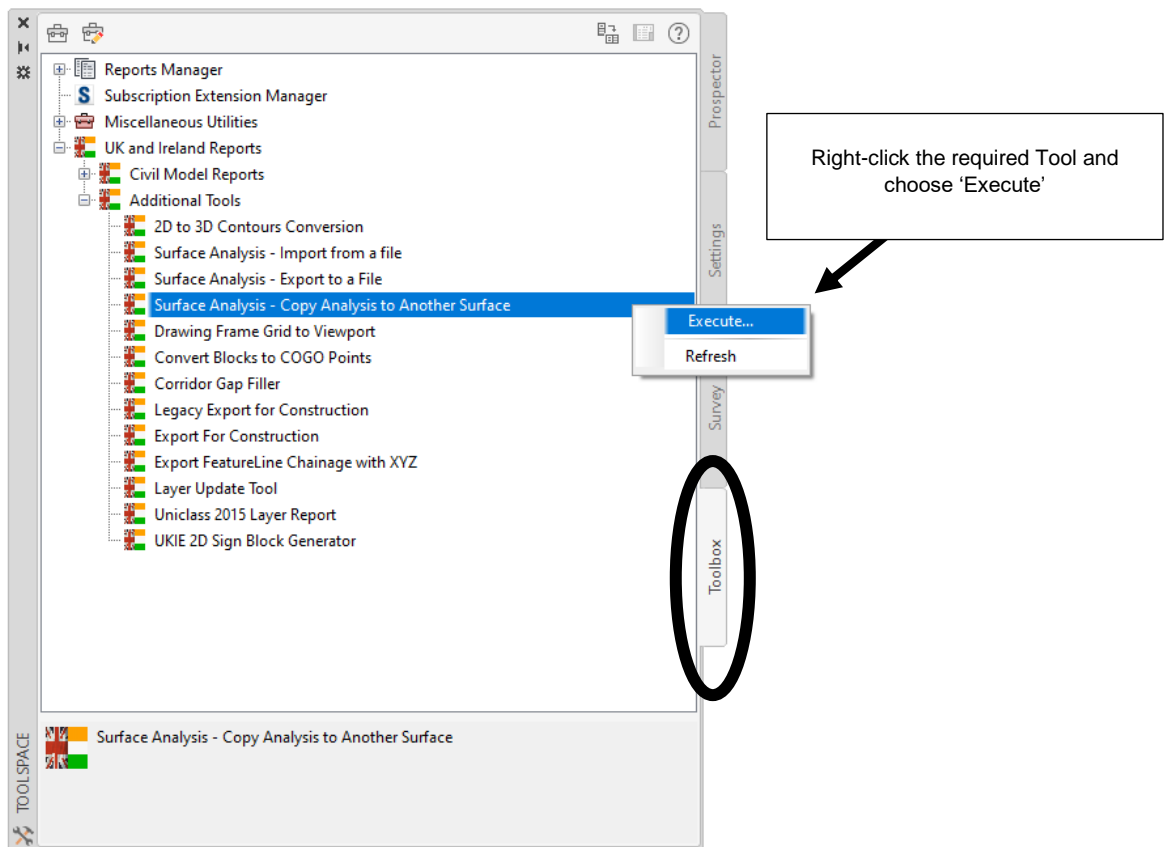

3.2.1 2D to 3D Contours Conversion

This utility allows you to specify a base height of a contour and a contour interval to assign the level of multiple 2D Contours.

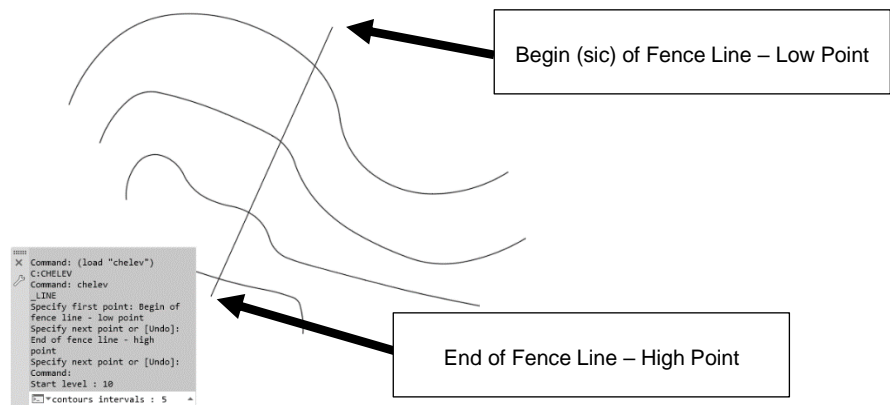

3.2.2 Surface Analysis – Import from a File

This utility allows you to import a file created using the 'Surface Analysis – Export to File' tool (see below, [Surface Analysis – Export to File](#)) to update the Analysis section of surface.

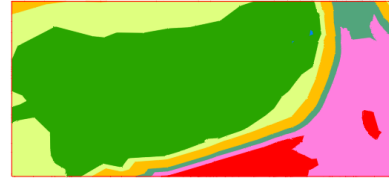

Surface Analysis data imported from a text file defined below

3.2.3 Surface Analysis – Export to File

This will export to a .txt file the ranges and colour schemes defined on the 'Analysis' tab of a selected surface. The scheme can then be imported to another surface (see above).

Very useful to create a library of Analysis ranges that can then be used in other drawings. This takes the leg work out of making colour schemes and ensures you maintain similar visual effects on surfaces between drawings.

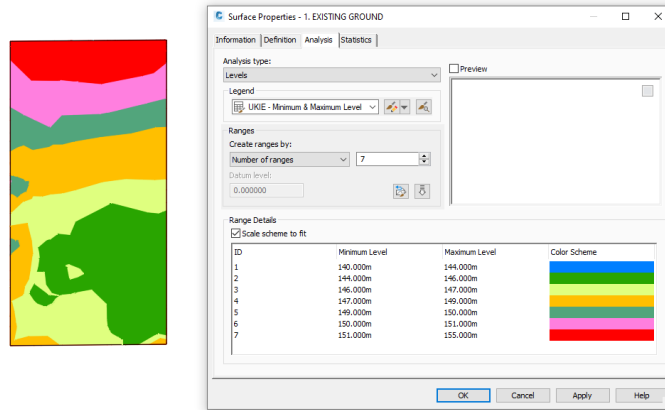

Surface showing a colour scheme assigned to various level ranges

3.2.4 Surface Analysis – Copy Analysis to Another Surface

This allows the transfer of 'Analysis' ranges between two surfaces in the same drawing. Simply select a surface as the 'source' and then choose the 'destination'. As long as the surfaces share the same style (in this case '2D Solid Level Banding'), the ranges will then display identically.

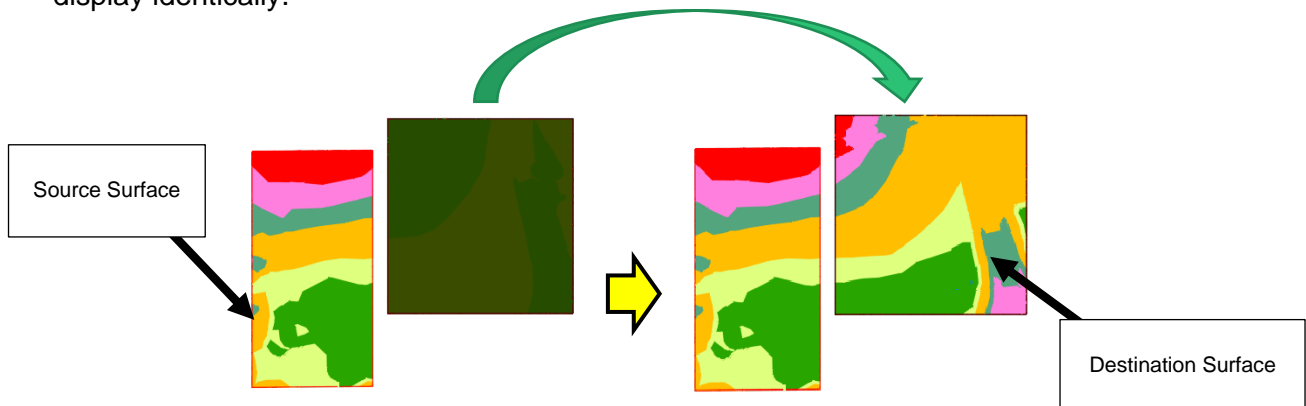

Surface showing a colour scheme assigned to various level ranges

3.2.6 Convert Blocks to COGO Points

This utility will add COGO points to match the X,Y and Z of Autocad blocks that are selected.

Enter a point description, and then select the blocks that you wish to convert. Note: The utility makes COGO points to match the blocks, it does not remove the blocks from the drawing.

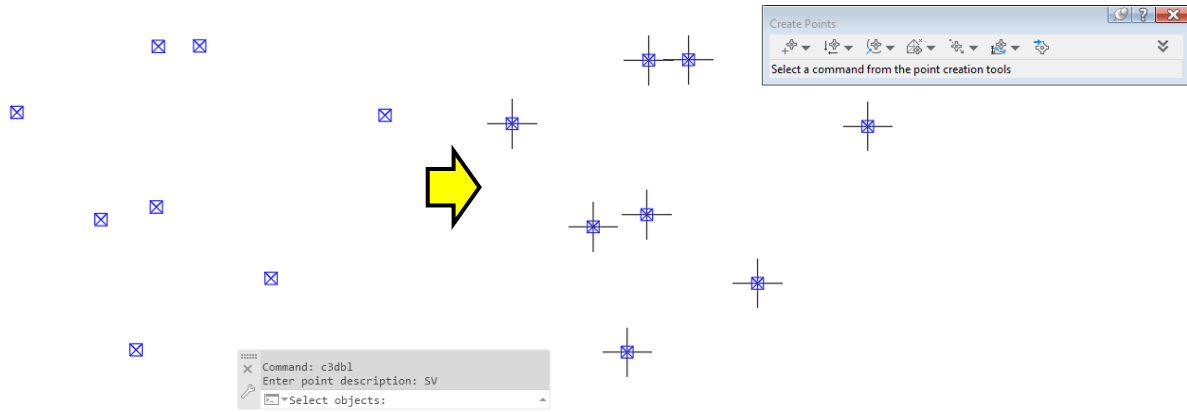

Making COGO Points from SVP blocks

3.2.7 Legacy Export Construction

This is the older variant of the tool described in the next section.

It is recommended that you use the newer variant in the next section.

3.2.8 Export Feature Line Chainage with XYZ

This will export the X, Y and Z points of a feature line and list the chainage.

Simply select the feature line, choose the name of the .CSV file to create a table of the relevant data.

	A	B	C	D
1	Civil 3D Feature Line Export			
2				
3	FeatureLine Name: crash barrier			
4	Chainage	X	Y	Z
5	0	252816	655316.9	120.4
6	117.895	252804.9	655199.5	121.2
7	195.704	252796.4	655122.2	121.4
8				

A 'Crash Barrier' Feature Line exported to .CSV

3.2.9 Export for Construction

This tool will create 3D Polylines from Feature lines or connected point codes in corridors.

This is useful to send basic 3D geometry to a contractor whose georeferenced equipment is set to follow 3D Polylines.

The screenshot shows the 'Export For Construction (UKIE)' dialog box with the following sections and callouts:

- Corridors:** A dropdown menu showing 'M: A650 THE BRANCH'. Callout: 'Choose 'All Corridors' to list all point codes in all available corridors. Alternatively, choose just one corridor to show point codes available in the selected corridor.'
- Feature Lines:** A list of checkboxes including '<No Display>', 'BackoffKerb', 'ChannelLine', 'Crown', 'FootpathInsideEdge', 'FootpathOutsideEdge', and 'TopofKerb'. Callout: 'Pick the point codes to export. These will match the point code names defined in the assemblies used in the selected corridor.'
- Sites \ Feature Lines:** A dropdown menu showing '<All Sites>' and a list of checkboxes including 'Boundary Fence' and 'crash barrier'. Callout: 'Pick the 'Feature Lines' to export.'
- Export Options:**
 - 'Use Existing AutoCAD Layer' (unchecked) with a dropdown set to '0'. Callout: 'Control the layer onto which the geometry is placed.'
 - 'Join AutoCAD Polylines' (checked). Callout: 'Selecting this checkbox will join together all exported geometry of the same type where possible.'
 - 'Save in a New Drawing' (checked) with a text field containing 'C:\CONTRACTOR\NEW POLYLINES.dwg'. Callout: 'When checked (recommended) this will place the resultant Polylines in a new drawing (make sure you choose the new drawing name!). If not selected, the polylines will be created in the current drawing.'
 - 'Export a 2D Drawing' (unchecked). Callout: 'This will create flattened 2D Polylines rather than 3D.'
 - 'Open the Drawing' (checked). Callout: 'This check box will open the new drawing created.'
- Buttons:** 'Export Feature Lines'. Callout: 'Press this box to run the Export.'

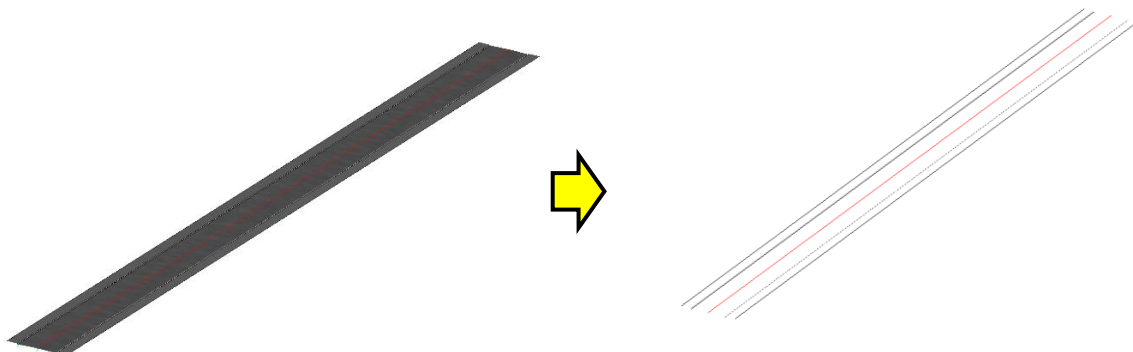

Export of Geometry from a corridor model to 3D Polylines

3.2.10 Layer Update Tool (previously the 'Layer Conversion Tool')

This utility is designed to allow you, quickly and easily, to update layers on older drawings to the latest defined standards.

Basically, in a nutshell, it brings your old drawing layer structure up to date to the naming set contained in the most recent UKIE Template. It also makes sure your old drawings have correct 'Object Defaults' based around the 2024 UKIE template. This is useful to ensure your drawing layers match the latest standards. This also helps to keep on top of the dynamically changing notations that define the Uniclass 2015 layering system.

The screenshot shows the 'UKIE Layer Update Tool' window. It is divided into several sections:

- Source Template:** Includes radio buttons for 'Current QNEW Template' (selected) and 'Custom Template or Drawing'. A text field below contains the path: 'C:\Users\joe...right.TOPONET\Documents\Layer Report.html'.
- Reporting Tools:** Includes checkboxes for 'Update Drawing' and 'Generate Report'. Below are radio buttons for report formats: 'WebPage' (selected), 'Excel', 'Word', 'PDF', and 'TextFile'. A text field shows the report path: 'C:\Users\joe...right.TOPONET\Documents\Layer Report.html'.
- Properties to be taken from Source:** A grid of checkboxes: Name (checked), LineType (unchecked), On (unchecked), Lock (unchecked), Transparency (checked), Colour (checked), LineWeight (checked), Plot (checked), Frozen (unchecked), New VP Freeze (unchecked).
- Other Options:** Includes checkboxes for 'Update Layer Filters' (checked), 'Delete Unmatched Filters' (checked), and 'Purge unused layers that are not compliant with Uniclass 2015' (checked).
- Process:** A large grey button at the bottom right.

Callout boxes provide the following information:

- Top Left:** The source template defaults to the default drawing template in your version of UKIE.
- Top Right:** Ticking the appropriate box will also update the selected properties of layers as they are being converted.
- Bottom Left:** Having 'Update Drawing' ticked will make changes, wherever possible, in the current drawing. The changes will be based on the contents of the 'source template'. Unticking this box will create a proposed report only and will not make any local updates.
- Bottom Left (Middle):** Ticking 'Generate Report' will create a report detailing each operation that is carried out (or will be carried out) during the update. Note: the best formatted report is 'WebPage'.
- Bottom Middle:** Layer filters can also be matched by ticking these two boxes.
- Bottom Right:** Press this button to run the conversion. The processing can be monitored via the progress meter on the AutoCAD status bar and verbosely on the AutoCAD command line.
- Bottom Center:** This box, when ticked, will check the resultant layers for Uniclass 2015 compliancy. If it finds unused layers than are not compliant, it will automatically purge them from the drawing.

The 'Layer Update Tool' performs the following checks (in order) to see if a layer needs to be updated or imported:

- Handle Match – when a layer’s identity is known to be common between previous UKIE templates (UKIE versions 2015 to 2024). This process now includes retired layer handles from previous releases of this country kit (these retired layers, if found, will be renamed with suffix ‘..Legacy’)
- Common Object Defaults – the layer is declared as an ‘Object Default’ and can be updated to match the same entry found in the source template
- Layer Mod – when a layer is identified as being modified from a known ‘Object Default’
- Missing Layer – layer exists in the source template but is missing from the local drawing

The 'Layer Update Tool' will always match the 'Object Defaults' to those found in the source template. It will also work through all the local drawing entities and change any objects that match a valid, identified, 'Object Default'.

This tool will only delete (purge) layers if the user requests it, and then only if the layers in question are unused and are not Uniclass 2015 compliant.

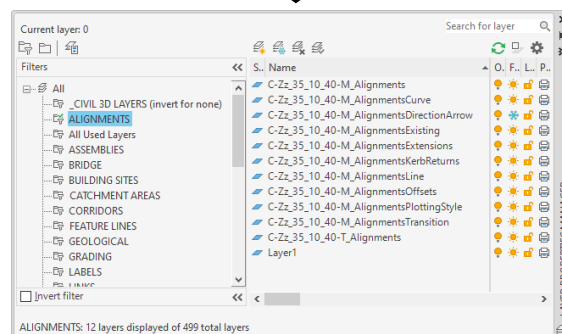
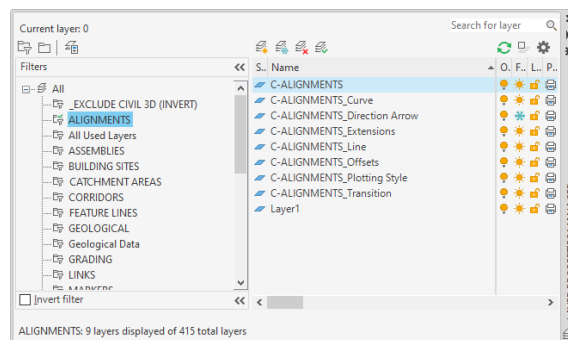

'Layer Conversion Tool' - Layers are renamed/added, Layer Filters are updated

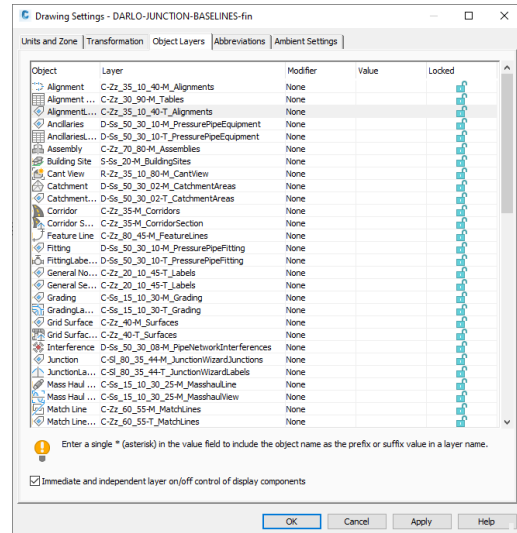
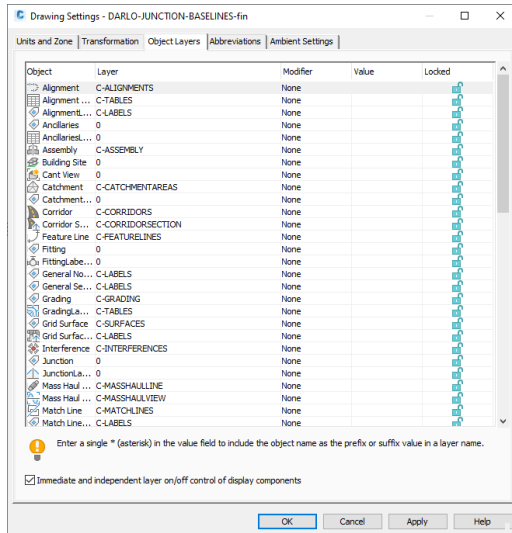

'Layer Conversion Tool' - Automatically updates 'Object Defaults'

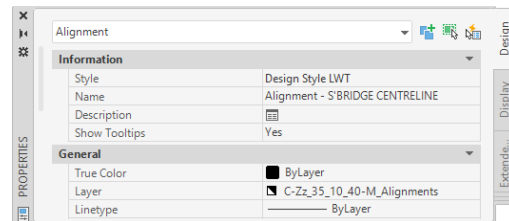
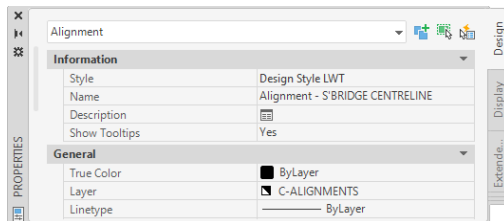

'Layer Conversion Tool' - Objects will have their layers changed to the new defaults

Note: This utility has been designed to work on drawings previously created with UKIE templates, but success can also be achieved, albeit to a lesser degree, on drawings derived from non-UKIE templates.

Note: As this utility makes multiple changes to your currently opened drawing, it is recommended that you save a copy of the original drawing, as a fall back, prior to running this utility.

Note: Uniclass compliancy is determined by the cached tables used in the 'Uniclass 2015 Layer Report' tool. Running the command 'UKIEUPDATECACHEDUNICLASSSTABLES' on the 'Command Line' will ensure the tables are up to date. This command will only be available if you have previously opened the 'Uniclass 2015 Layer Report' tool.

3.2.11 Uniclass 2015 Layer Report

This utility creates one of three reports designed to clearly identify which layers in the drawing are matched to, or non-compliant with, the NBS Uniclass 2015 standard.

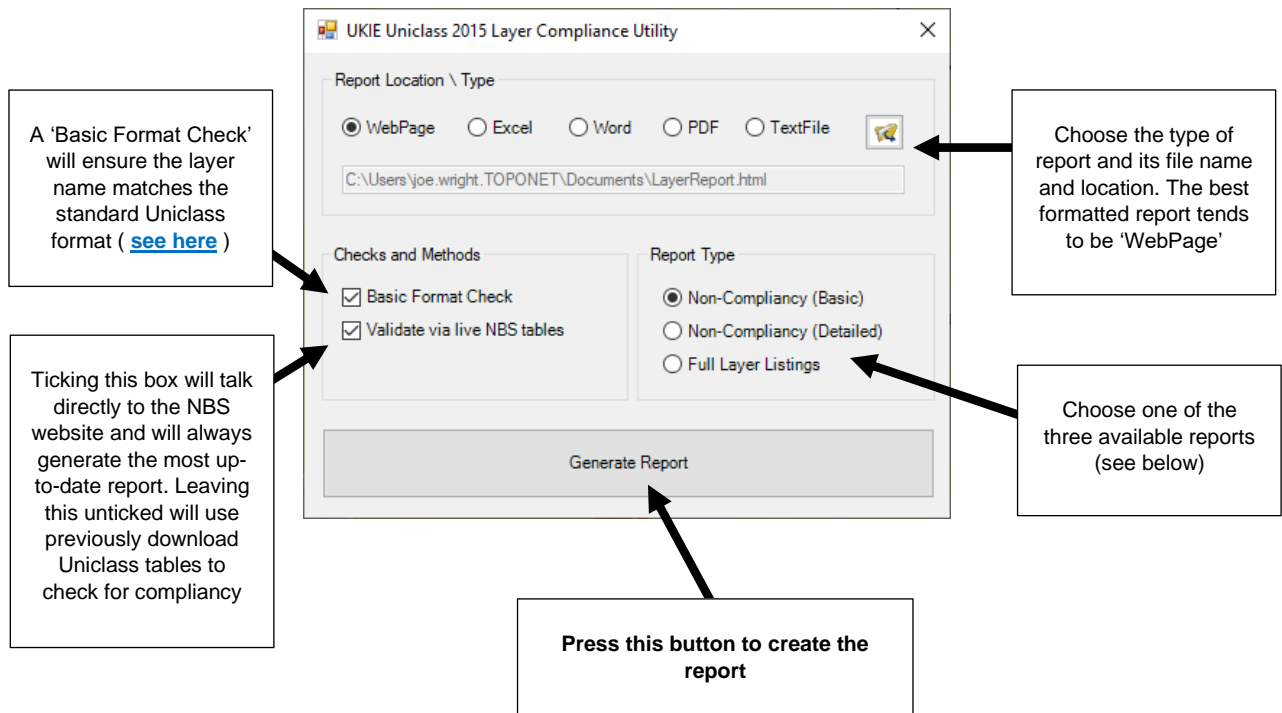

The three reports available to you are:

- **Non-Compliance (Basic)** – This will list all the layers that are not compliant. Formatting errors will be highlighted as well as notational errors checked against the NBS tables.
- **Non-Compliance (Detail)** - This will list all the layers that are not compliant. Formatting errors will be highlighted. Notational errors checked against the NBS tables will highlight the point in the notation tree that does not exist.
- **Full Layer Listings** – This will list all layers. Each layer will be shown as compliant or not compliant by using the 'Basic Format Check' along with the notations from the Uniclass tables. Where non-compliant layers are found, a reason for failure is given, along with failure point (if relevant). Where compliant layers are found, a verbose translation of the Uniclass 2015 notation is listed.

Examples of each report are show on forthcoming pages.

Note: 'Validating via live NBS tables' requires an internet connection, and this process may cause performance issues during report creation. As this service is provided by an external third party, the utility may not be tolerant of future external schema changes, or it may become unavailable due to other restrictions.

Note: A full cached copy of the 'Uniclass Tables' is included along with the country kit and this can be used by unticking the 'Validate via live NBS tables' box.

Uniclass 2015 - Basic Report Of Non-Compliant Layers (Drawing2.dwg)

Client:

Jason Ensell
Autodesk Limited
New Hampshire

Prepared by:

Joe Wright
toponet.co.uk
Beckermonds

Uniclass Tables Used:

Zz - CAD downloaded on 03/05/2023
Ss - Systems downloaded on 03/05/2023
Ac - Activities downloaded on 03/05/2023
SL - Spaces/ locations downloaded on 02/05/2023
FI - Form of information downloaded on 03/05/2023
Pr - Products downloaded on 02/05/2023

Prepared On:

03 May 2023

Layer	Compliant	Reason
0	False	0: [ReservedByAutoCAD]
Defpoints	False	Defpoints: [ReservedByAutoCAD]

A 'Non-Compliance (Basic)' report run against an empty drawing based on the UKIE 2024 template

Uniclass 2015 - Detailed Report Of Non-Compliant Layers (Drawing2.dwg)

Client:

Jason Ensell
Autodesk Limited
New Hampshire

Prepared by:

Joe Wright
toponet.co.uk
Beckermonds

Uniclass Tables Used:

Zz - CAD downloaded on 03/05/2023
Ss - Systems downloaded on 03/05/2023
Ac - Activities downloaded on 03/05/2023
SL - Spaces/ locations downloaded on 02/05/2023
FI - Form of information downloaded on 03/05/2023
Pr - Products downloaded on 02/05/2023

Prepared On:

03 May 2023

Layer	Compliant	Breakdown
0	False	0: [ReservedByAutoCAD]
Defpoints	False	Defpoints: [ReservedByAutoCAD]
C-Zz_70_50-T_ViewFrames	False	Zz: CAD Zz_70: Views Zz_70_50: [NotFound]
C-Ss_40_10_90_16-M_RoadSignsBorder	False	Ss: Systems Ss_40: Signage, fittings, furnishings and equipment (FF&E) and general finishing systems Ss_40_10: Signage systems Ss_40_10_90: Traffic signage and marking systems Ss_40_10_90_16: [NotFound]

A 'Non-Compliance (detailed)' report showing notational failures

Uniclass 2015 - Full Layer Report (Compliant \ Non Compliant)

(C:\Users\joe.wright.TOPONET\Documents\Beckermonds-Mast.dwg)

Client:
 Jason Ensell
 Autodesk Limited
 New Hampshire

Prepared by:
 Joe Wright
 toponet.co.uk
 Beckermonds

Uniclass Tables Used:
[Zz - CAD](#) downloaded on 03/05/2023
[Ss - Systems](#) downloaded on 03/05/2023
[Ac - Activities](#) downloaded on 03/05/2023
[FI - Form of information](#) downloaded on 03/05/2023

Prepared On:
 03 May 2023

Layer	Compliant	Reason
0	False	0: [ReservedByAutoCAD]
Defpoints	False	Defpoints: [ReservedByAutoCAD]
C-Zz_20_10_45-T_Labels	True	CAD \ Textual content \ Annotation \ Labels
C-Zz_30_90-M_Tables	True	CAD \ Insertions \ Tables and schedules
C-Zz_70_80-M_Assemblies	True	CAD \ Views \ Sections
S-Ss_20-M_BuildingSites	True	Systems \ Structural systems
C-Zz_35-M_Corridors	True	CAD \ Setting out
C-Zz_35-M_CorridorSection	True	CAD \ Setting out
C-Zz_80_45-M_FeatureLines	True	CAD \ Presentation \ Lines
C-Ss_15_10_30-M_Grading	True	Systems \ Earthworks, remediation and temporary systems \ Groundworks and earthworks systems \ Excavating, filling and erosion control systems
C-Zz_40-M_Surfaces	True	CAD \ Topography
D-Ss_50_30_08-M_PipeNetworkInterferences	False	Ss_50_30_08: [NotFound]
C-Ss_15_10_30_25-M_MasshaulView	True	Systems \ Earthworks, remediation and temporary systems \ Groundworks and earthworks systems \ Excavating, filling and erosion control systems \ Earthworks excavating systems
C-Zz_60_55-M_MatchLines	True	CAD \ Drawing symbols \ Match lines
C-Zz_70_80-M_Sections	True	CAD \ Views \ Sections
C-Zz_50_60-M_Plots	True	CAD \ Zones and boundaries \ Parcels
D-Ss_50_30_08-M_PipeNetworkPipes	False	Ss_50_30_08: [NotFound]
C-Zz_35_10_90-M_Profiles	True	CAD \ Setting out \ Alignments and super elevations \ Vertical alignment
C-Zz_70_80-M_ProfileViews	True	CAD \ Views \ Sections
C-Zz_10_20-M_Sheets	True	CAD \ Title sheet \ Drawing frame
C-Zz_70_80-M_SubAssemblies	True	CAD \ Views \ Sections
G-Ac_15_80-M_SurveyFigures	True	Activities \ Survey activities \ Site surveying
G-Ac_15_80-M_SurveyNetworks	True	Activities \ Survey activities \ Site surveying
C-Zz_70_60-M_Viewframes	True	CAD \ Views \ Plans
C-Zz_35_60-M_SurfacesPoints	True	CAD \ Setting out \ Points
C-Zz_40-M_SurfacesTriangles	True	CAD \ Topography
C-Zz_40-M_SurfacesBorder	True	CAD \ Topography
C-Zz_40_15_50-M_SurfacesMajorContours	True	CAD \ Topography \ Contours \ Major contours

A 'Full Layer Listing' report showing both compliant and non-compliant layers

3.2.12 UKIE 2D Sign Block Generator

This utility is designed to quickly find and insert UK signage blocks.

This tool has been developed primarily for basic 2D dynamic block insertion and has been released into the UKIE country kit ahead of the launch of the 'Autodesk 3D Sign and Road Marking' utility.

The screenshot shows the 'UKIE 2D Sign Insertion Tool' window. At the top, there are three search criteria: 'Schedule' (set to 'All'), 'Shape' (set to 'All'), and 'Free Text Filter' (set to 'motorway'). Below this is a table of 'Available Signs' with columns for 'Designation' and 'Description'. The sign 'P872MWLM' is selected. To the right, a 'Sign to be inserted' preview shows a blue sign with a white arrow and the text '200 yards'. Below the preview, there are fields for 'Original Units' (Stoke Width (xht/4)), 'Sized as' (x-height (xht) in mm), and 'Shape' (Rectangular). A 'Size' dropdown is set to '120'. An 'INSERT' button is at the bottom right.

Callout boxes provide the following information:

- Top Left:** This selection box will limit the available signs to those within the listed schedules
- Top Middle:** This selection box will limit the available signs to those of the chosen shape
- Top Right:** The 'Free Text Filter' will limit the selectable signs to text contained in the 'Designation' or 'Description' columns
- Bottom Left:** Select the sign from the list and the thumbnail preview will be updated to reflect the chosen sign
- Bottom Middle:** Choose the size of the sign from the list of sizes shown. The properties shown next to 'Original Units' and 'Sized as' will indicate how the sign has been authored and will highlight sizing options
- Bottom Right:** Press this button to insert the sign into the drawing

Insertion of the selected sign will be scaled to meet the chosen size. The size will be converted into metres regardless of the 'Original Units' and the block will appear 1:1 in the drawing. In larger schemes you may need to zoom in to see the result of the placement.

For example: Inserting a 600mm diameter sign will be 0.6m in the drawing.

UKIE 2D Sign Block Generator - Schedules supported from 'Traffic Signs Regulations and General Direction (TSRGD)'

The signage blocks referenced in this utility have been based around the schedules listed in TSRGD 2016. The blocks were created referencing the appropriate 'Department of Transport (DOT)' drawing and where possible the block name or description includes the DOT drawing number.

Not all of the available schedules are currently included. It is expected that this library will grow to encompass the missing schedules in future releases of the county kit.

The table below shows which schedules are currently adopted in the UKIE Civil 3D Country Kit 2024 v1:

Schedule	
2	Triangular warning signs including fixed and variable plates
3	Circular regulatory signs including fixed and variable plates
9	Regulatory signs and associated plates
10	Speed limit signs
11	Informational signs including fixed and variable plates
12	Directionals signs (motorway, primary, non-primary, parking, tourist, MOD, good vehicles, cyclists and pedestrians)
13	Temporary signs (but not part 6)
17	Supported through the Transport Medium, Transport Bold and Transport Motorway font set and associated AutoCAD text styles.

List of supported schedules

Each schedule can be filtered in the utility so that only items relating to the chosen schedule are listed. (In the case of Schedule 12 the subsections are also filterable)

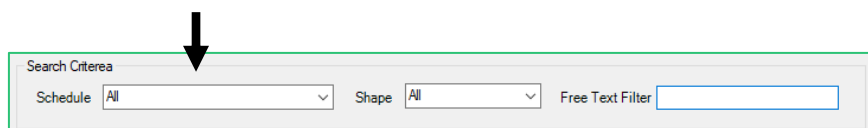

UKIE 2D Sign Block Generator - General Usage

Some of the blocks have handed variants (e.g., 'Bend Ahead to Right' and 'Bend Ahead to Left'). Many of the blocks are dynamic, and you will find that changes such as stretching and flipping, as well as the modification of attributes, can be achieved after insertion.

A number of the blocks also employ both methods. That is being handed (separate part numbers) with attributes and dynamic grips.



Handed Blocks – Bend ahead to right, Bend ahead to left

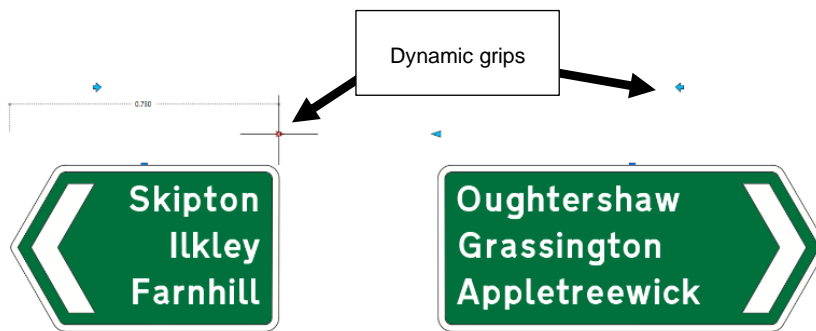

Dynamic Blocks – Horizontal size and direction can be controlled by grips.

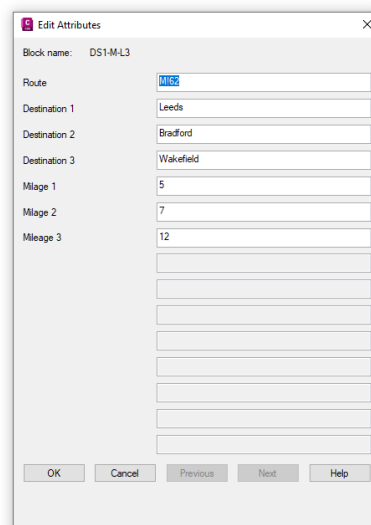

Attributes – variable legends are controlled by attributes

Each block is assigned a shape. The shape can be easily filtered by selecting the desired shape in the search criteria.

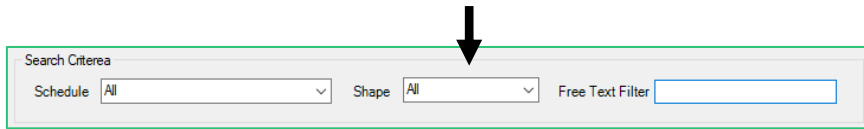

Basic shape filters have been included: Circular, Rectangular, Hexagonal and Triangular.

In addition to these, and for simplicity, 'Fixed' and 'Variable' plate filters have been added.

'Fixed Plates' are blocks that directly appear in the TSRGD schedules. If they include milage variations, or possible name changes, then they will include attributes, and can be re-sized dynamically in the horizontal plane.

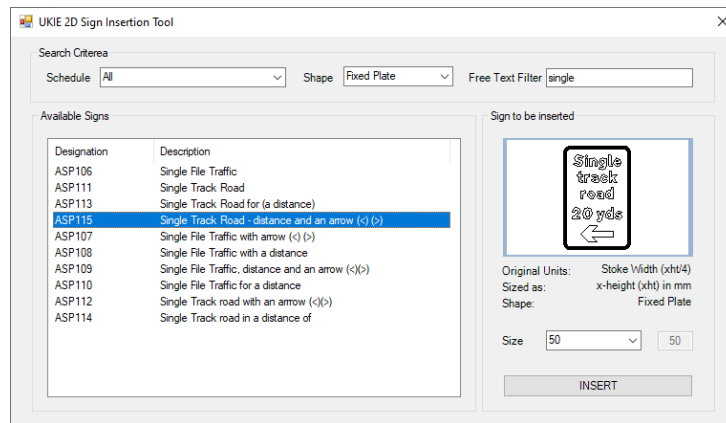

Fixed Plates can be filtered under 'Shape'

'Variable Plates' are generic. If you cannot find a 'Fixed Plate' to suit your needs, then a 'Variable Plate' will allow you to create a custom legend plate. They are based on the directional plate styles in schedule 12. They can be used for general purpose needs. All lines are attributed, horizontal sizing is dynamic.

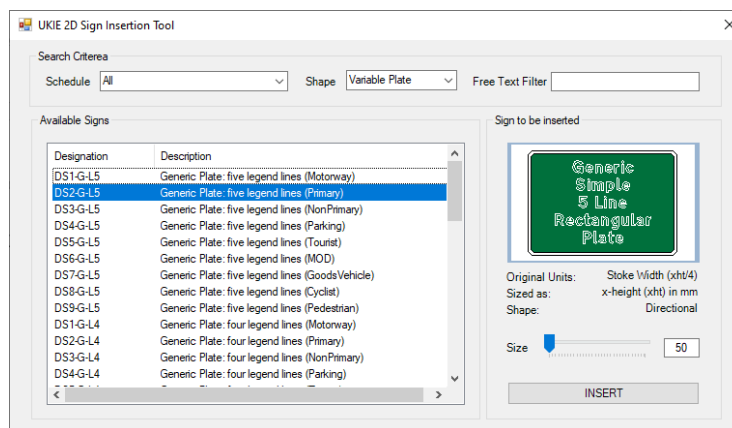

Variable Plates can be filtered under 'Shape'

UKIE 2D Sign Block Generator - Block Sizing, Original Units and Insertion Points

The original sizes of the blocks have been drawn as detailed in the individual drawings outlined in TSRGD 2016. This can be simplified to four methods of sizing:

- **‘Single Size’** – only one size is presented. It is unchangeable.
- **‘External Dimension’** – the size represents an external height, or width, or diameter.
- **‘x-Height’** – the size will be controlled by the legend. The size is representative of the height of a lower case ‘x’ in the font used.
- **‘Stroke width’** – drawn in units one quarter of the ‘x-Height’. For convenience (and to aid the user) this type of block also lists in terms of ‘x-height’.

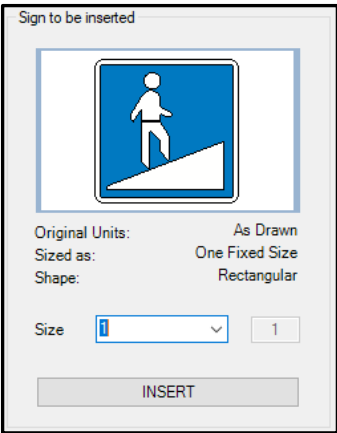
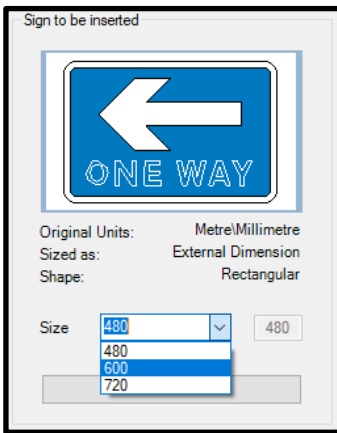
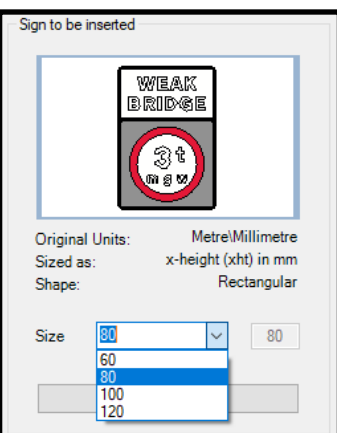
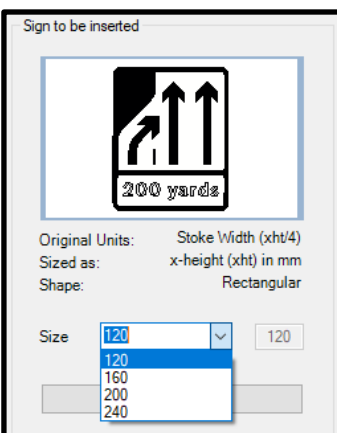
 <p style="text-align: center;"><u>Single Size</u></p>	 <p style="text-align: center;"><u>External Dimension</u></p>
 <p style="text-align: center;"><u>x-Height</u></p>	 <p style="text-align: center;"><u>Stroke Width</u></p>

Note: Some blocks that have legends removed may still be referenced in ‘x-Height’ or ‘Stroke Width’.

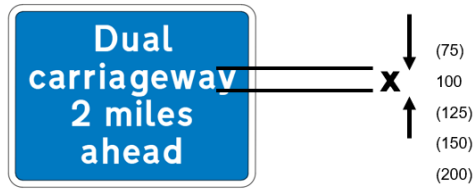

x-Height (xht) represents the height of a lower case 'x'

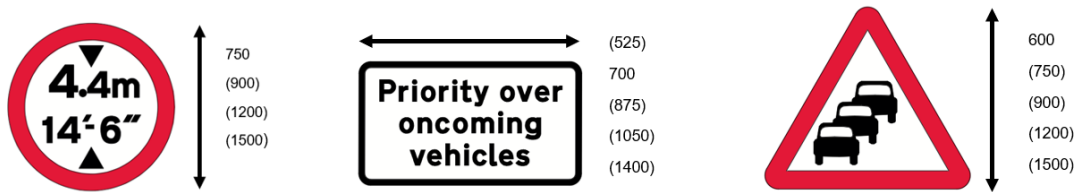

External Dimensions can be overall diameter, width or height



All blocks share the same insertion point. Top / Centre

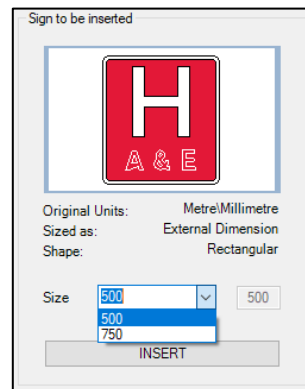
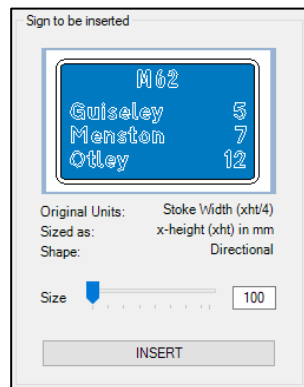

Some signs have a variable size selection, some have fixed size choices

UKIE 2D Sign Block Generator - Fonts, AutoCAD Styles and character sets

The following windows fonts are installed along with the UKIE country kit, these are used to create the legends on signs and plates:



Windows Font	AutoCAD Style	Implements (TSRDG)
UKIE-TRANSPORT HEAVY	TRANSPORTHEAVY	Transport Heavy
UKIE- TRANSPORT MEDIUM	TRANSPORTMEDIUM	Transport Medium
UKIE-TRANSPORT MOTORWAY	TRANSPORTMOTORWAY	Transport Motorway

These AutoCAD styles are not loaded by default in the UKIE 2024 template file. They import to the current drawing only when you use the sign tool. If unused, these text styles can be purged out of the drawing.

These fonts have special characters assigned to them in accordance with Schedule 17 of TSRGD 2016. These, on the whole, map to sensible characters on the keyboard. See the table below:

Key		Key		Key	
\$		{		#	
@		}		/	
~		^		\	
<		=		>	

Additional keyboard mappings are also available that help to control the spacing between text as differing spacing options are specified in TSRGD 2016. These can be mixed to achieve 3sw(++), 3.5sw(!_!) and 4sw(_+). Whilst the spacebar will, by default, create a 2.5sw gap in the text, it is recommended to use the underscore character for readability when editing the attributes.

Key	Name	Width	Examples	
␣	spacebar	2.5sw	better to use the underscore	
_	underscore	2.5sw	All_traffic_>	
+	plus	1.5sw	Merge++\$+Mile	
!	exclamation	1sw	Height_6!#!6"	

Note: The 'Transport Motorway' text style is, by design, absent of many keyboard characters. The missing characters will appear as 'x' if used. These are characters that are not supported. (See section 17 of TSRGD 2016)

4.0 Pipe Networks

4.1 Overview

The UKIE Country Kit has many enhancements to help with Pipe Network design.

The UKIE Country Kit contains structures, pipes and styles to fully support the standards contained within the 'Sewers For Adoption (7th Edition)' specification.

Additional support is included for 'DMRB', 'BT Openreach', 'Transco Gas' and 'Virgin Media'.

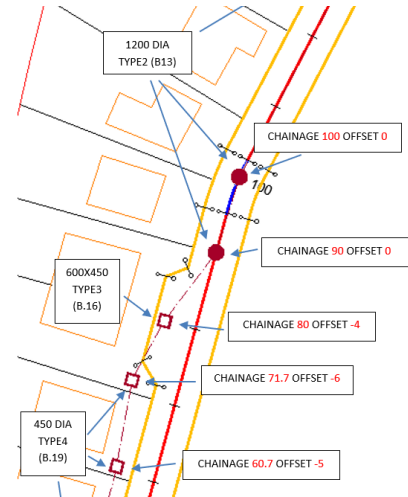

4.2 Network Catalogs

There are a number of network catalogs included in the UKIE Country Kit. As a general rule, you should set the 'Pipe Catalog' to 'UK IE Metric Pipe Catalog' and the 'Structure Catalog' to 'UK IE Metric Structure Catalog'. This is the default in UKIE 2021 and above. It is worth checking these are set as below (type 'AeccSetNetworkCatalog' on the command line):

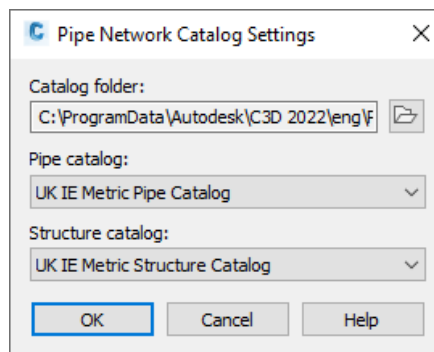

Selecting other catalogs will require new parts lists to be generated from scratch, and this process is not covered by this document.

IMPORTANT: Use the catalogs shown above.

4.3 Pipe Network Setting

4.3.1 Parts Lists

The following parts lists are contained in the default UKIE Template. If you use one of these 'Parts Lists' then the styling and rules associated with the list will automatically be applied during your design.

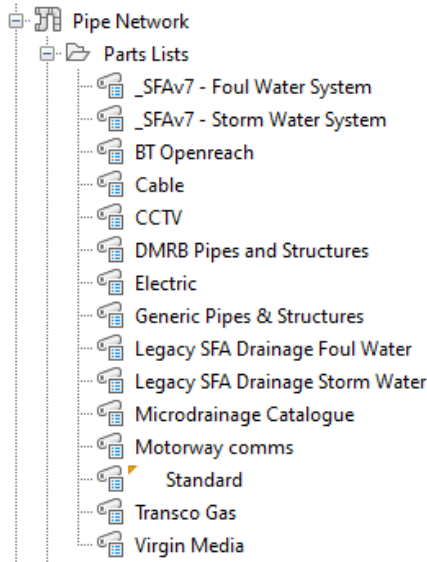

Note:

The only list that needs a catalog change is the 'Microdrainage Catalogue'. If you wish to use this, then please follow the documentation < [here](#) >. All other parts lists work out of the box and assume that the catalogs have been set as in < [Network Catalogs](#) >.

4.4 Pipe Settings

4.4.1 Pipe Styles

The following pipe styles are available:

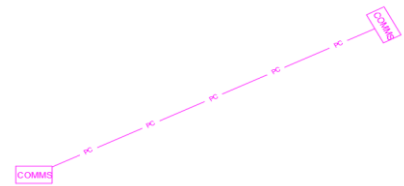
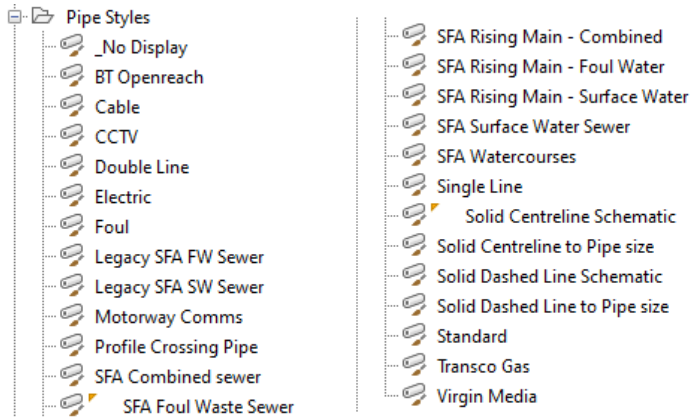

Pipe Style assign as 'Motorway Comms'

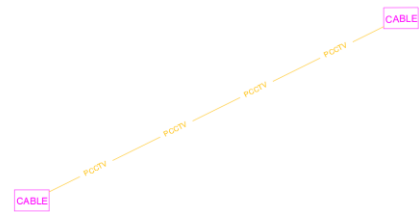

Pipe Style assign as 'CCTV'

4.4.2 Pipe Rule Sets

The following Pipe Rule sets are available:

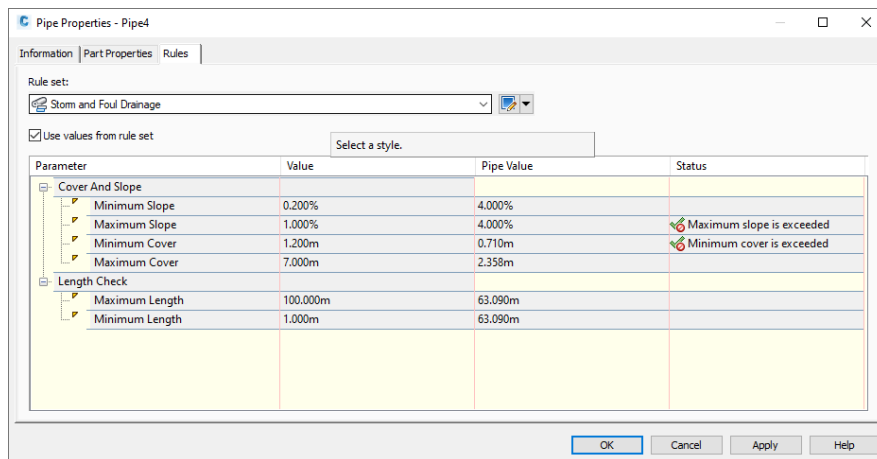
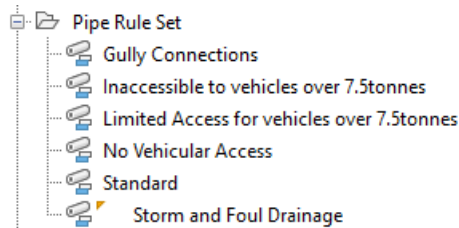

Cover and Slope rules reporting as compromised using the 'Storm and Foul Drainage' rule

4.4.3 Pipe Label Styles

The following Pipe Label Styles are available:

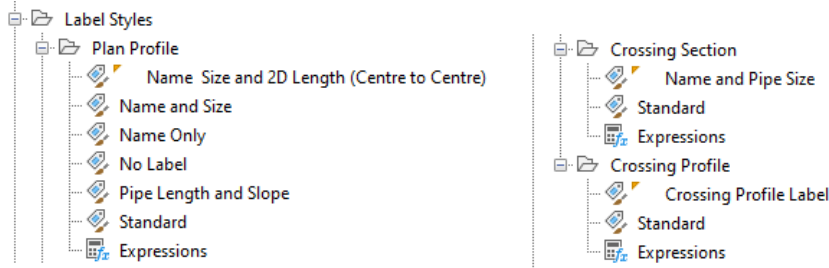

Pipe Labeled with 'Pipe Length and Slope'

4.4.4 Pipe Table Styles

The following Pipe Table Styles are available:

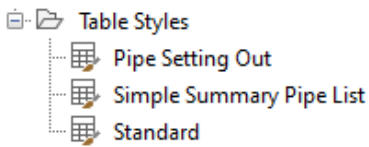

Pipe Table					
Pipe Name	Size (mm)	Plan Length (m)	Slope	Start Invert Level	End Invert Level
Pipe27	300	18.000	1.01%	9.446	9.264
Pipe28	300	11.045	0.20%	9.244	9.222
Pipe29	300	8.538	0.20%	9.202	9.185
Pipe30	300	10.770	0.20%	9.165	9.143
Pipe31	300	9.989	0.20%	9.123	9.103
Pipe32	300	34.998	0.20%	9.083	9.013
Pipe33	110	13.431	0.20%	10.683	10.656
Pipe34	110	4.218	0.20%	10.636	10.628
Pipe35	110	13.036	0.20%	9.244	9.218
Pipe36	110	4.172	0.20%	9.198	9.189
Pipe37	110	6.336	0.20%	9.169	9.157
Pipe38	110	4.626	0.20%	9.198	9.188
Pipe39	110	9.580	0.20%	9.202	9.182
Pipe40	110	5.234	0.20%	9.162	9.152
Pipe41	110	7.887	0.20%	9.132	9.116
Pipe42	110	6.872	0.20%	9.096	9.082
Pipe43	110	4.875	0.20%	9.165	9.155
Pipe44	110	9.569	0.20%	9.135	9.116

Pipe table inserted with the 'Pipe Setting Out' style

4.5 Structure Settings

4.5.1 Structure Styles

The following structure styles are available:

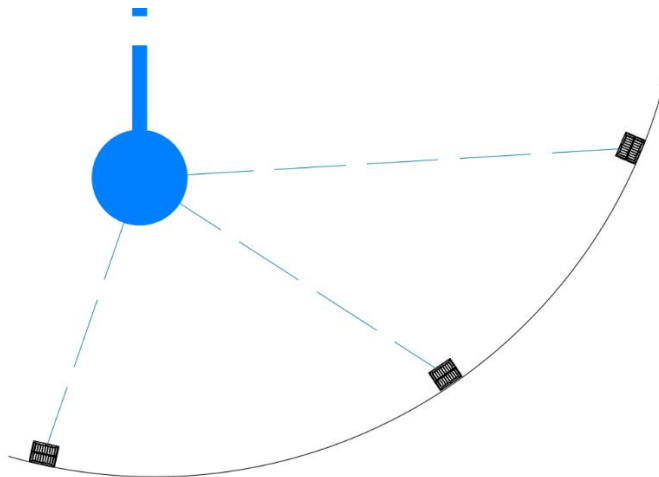
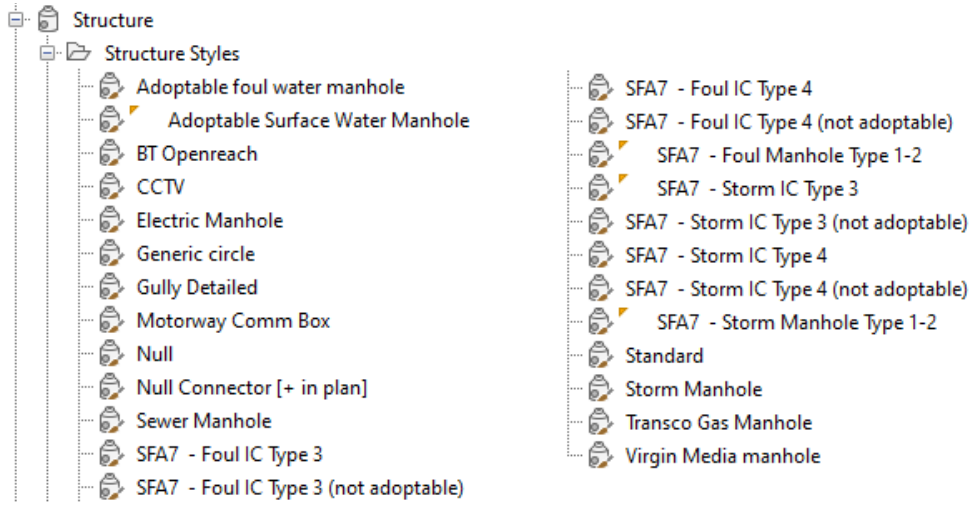

Manhole displayed as 'Generic Circle and Gullies assigned the 'Gully Detailed' style

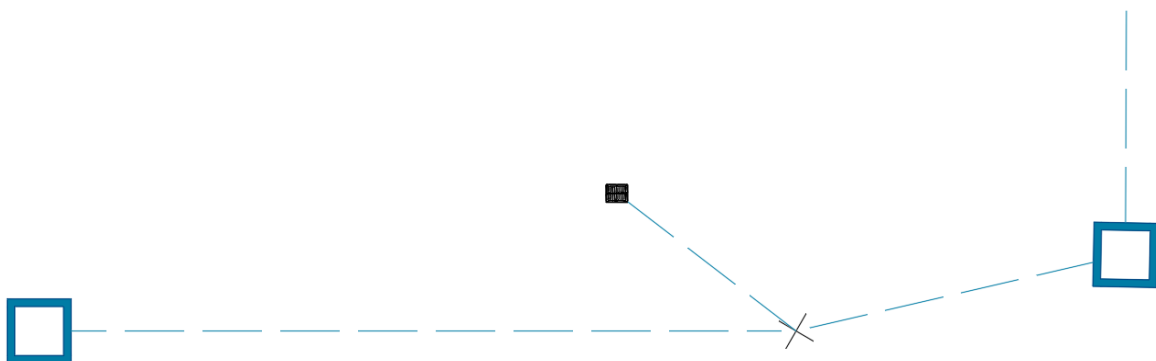

Connection Gully shown with a Null structure shown in the style 'Null Connector [+ in plan]'

4.5.2 Structure Rule Sets

The following structure rule sets are available:

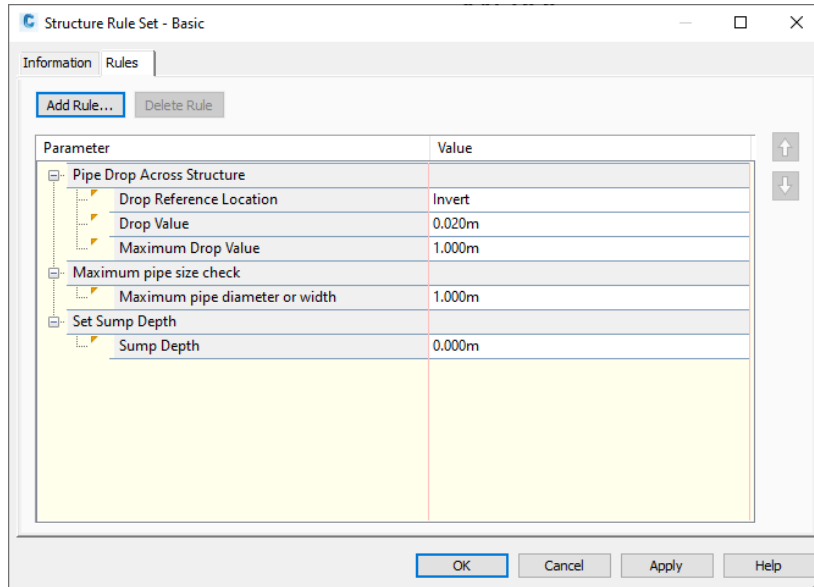
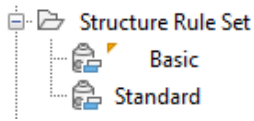

Rules assigned to the 'Basic' Structure Rule Set

4.5.3 Structure Label Styles

The following structure label styles are available:

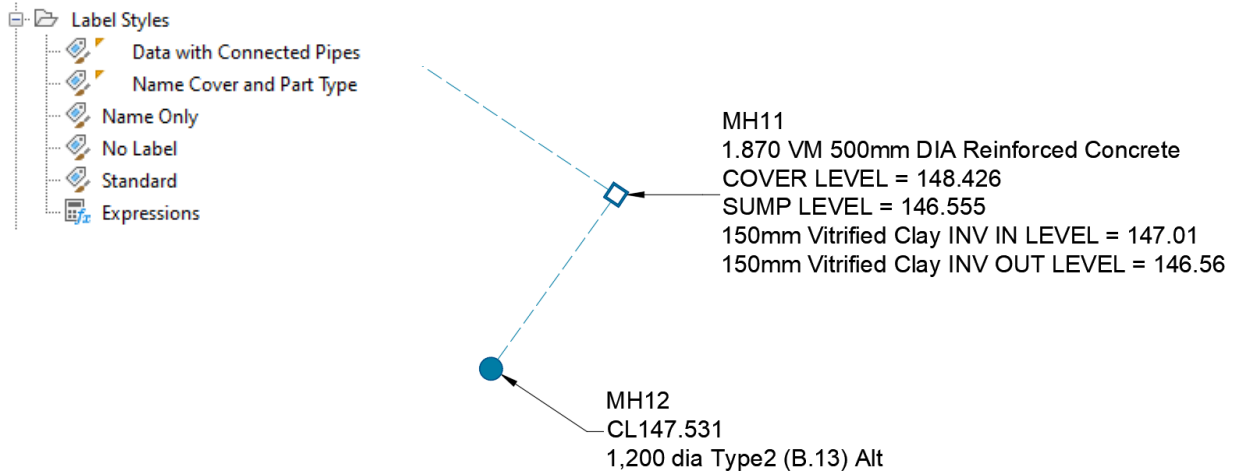

Manholes labeled with 'Data with Connected Pipes' and 'Name Cover and Part Type'

4.5.4 Structure Table Styles

The following structure tables styles are available:

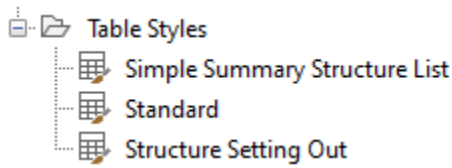

Structure Table				
Structure Name	Easting	Northing	Cover Level	Connected Pipes
MH33	449436.241	535448.149	12.001	Pipe27 Inv. 9.446 Pipe33 Inv. 10.683
MH34	449440.954	535465.521	11.748	Pipe27 Inv. 9.264 Pipe28 Inv. 9.244 Pipe35 Inv. 9.244
MH35	449442.869	535476.399	11.700	Pipe28 Inv. 9.222 Pipe29 Inv. 9.202 Pipe39 Inv. 9.202
MH36	449446.973	535483.886	11.372	Pipe29 Inv. 9.185 Pipe30 Inv. 9.165 Pipe43 Inv. 9.165
MH37	449453.452	535492.489	11.353	Pipe30 Inv. 9.143 Pipe31 Inv. 9.123
MH38	449456.412	535502.030	11.253	Pipe31 Inv. 9.103 Pipe32 Inv. 9.083
MH39	449472.647	535533.034	10.904	Pipe32 Inv. 9.013
MH40	449423.295	535451.728	12.188	Pipe33 Inv. 10.656 Pipe34 Inv. 10.636
MH41	449422.193	535447.657	12.380	Pipe34 Inv. 10.628
MH42	449428.423	535469.115	11.579	Pipe35 Inv. 9.218 Pipe36 Inv. 9.198 Pipe38 Inv. 9.198

Schedule added using the 'Structure Setting Out' table style

4.6 Band Sets

4.6.1 'Pipe Network' Band Set

A 'band set' called 'Pipe Network' can be assigned during profile creation or imported after profile creation.

An example of the data that the 'band set' displays is shown below:

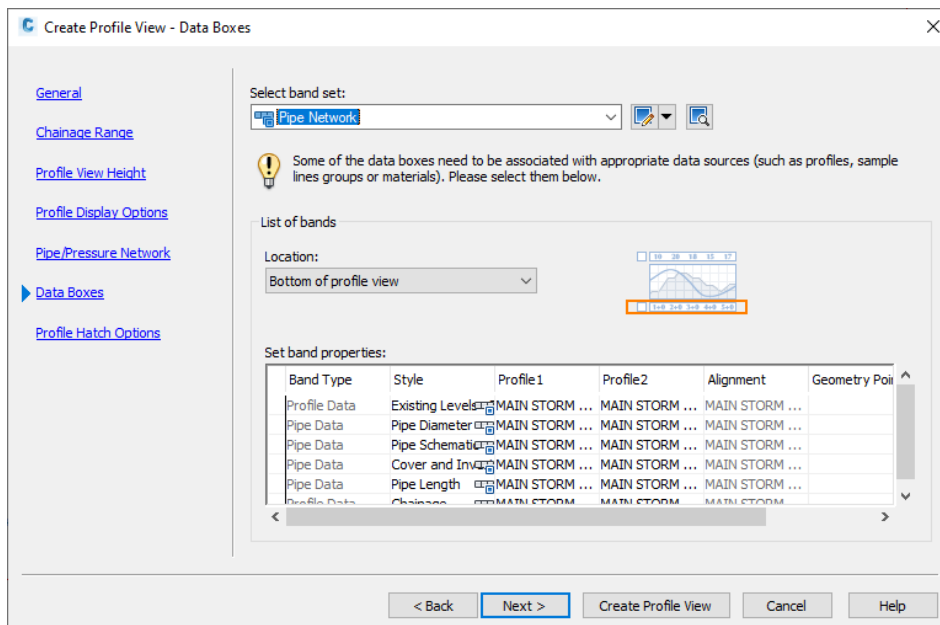
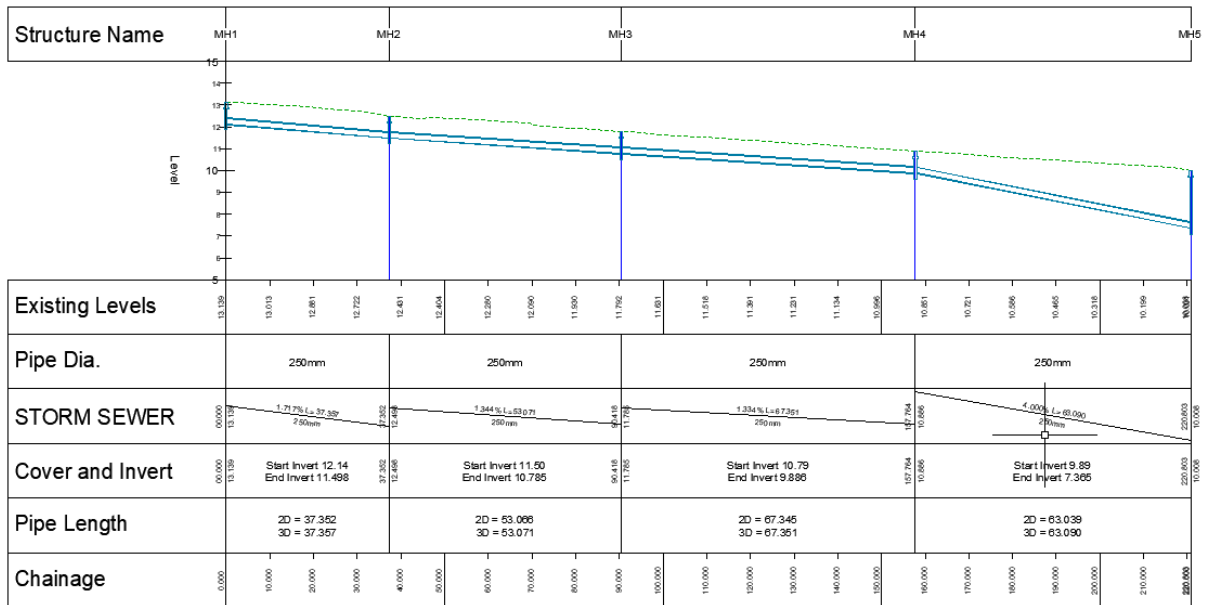

Assigning the 'Pipe Network' Band Set during profile creation

4.7 Support for Sewers for Adoption (7th Edition)

4.7.1 Overview

'Sewers For Adoption' is the standard used by the water and sewage companies in England and Wales. Scotland has a variant of this standard 'Sewers for Scotland V4'.

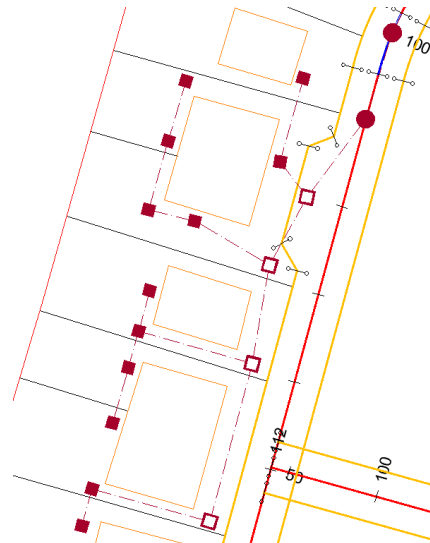

4.7.2 Catalog Selection

Use the default 'UK IE Metric Structure Catalog'. Do **NOT** use 'UKIE – Sewers for Adoption V7 (SFA7) with connectors', this catalog is currently not fully implemented.

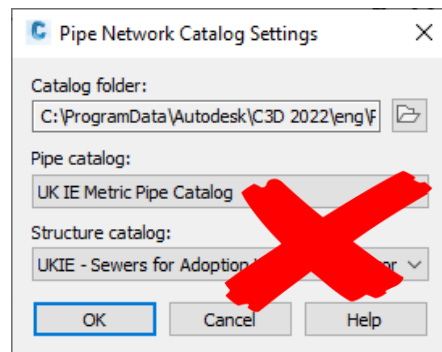
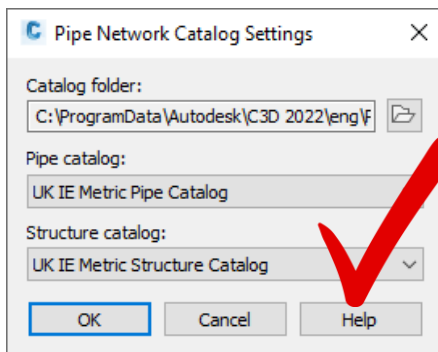

IMPORTANT: Use the catalogs shown above.

4.7.3 Parts Lists (SFAv7)

A full list of manhole designations is available and a sample selection of pipes for both Foul and Storm networks.

The parts lists are preceded with an underscore character ('_') in order to prioritize the position during selection.

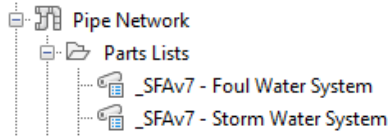

When creating a pipe network use ‘__SFAv7 - Foul Water System’ to design a foul network and ‘_SFAv7 - Storm Water System’ to design a clear water system.

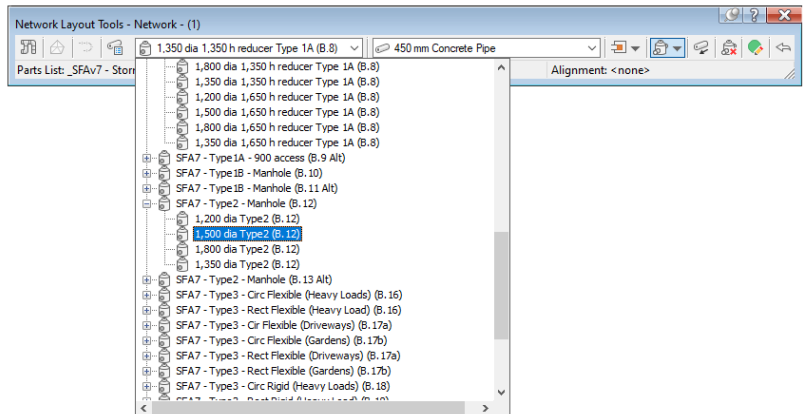
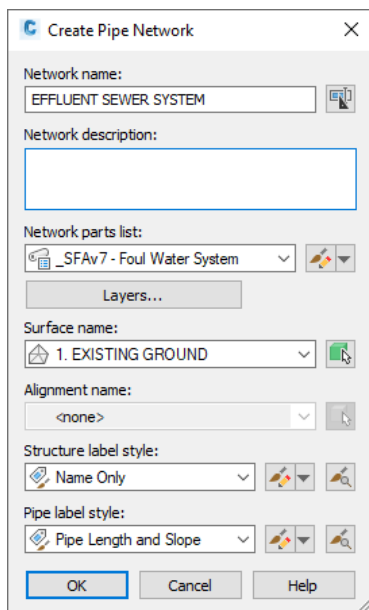

Creating a pipe network from the ‘SFAv7 - Foul Water System’ network parts list

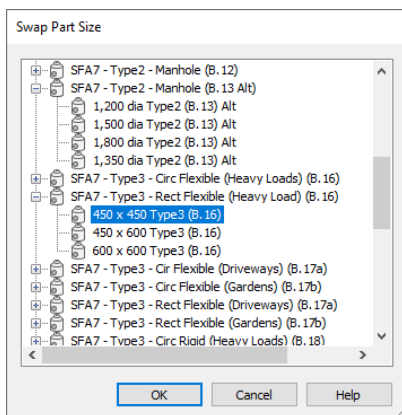

Changing ‘Manhole’ designations after insertion

4.7.4 Structures (SFAv7)

Each network structure has a description that identifies the manhole, and a reference is included to the item as it is listed in the ‘Sewers for Adoption’ book. For example, the ‘SFA7 – Type1B – Manhole (B.10)’ can be referenced through the ‘Sewers for Adoption’ book by looking at ‘FIGURE B.10’ (page 23).

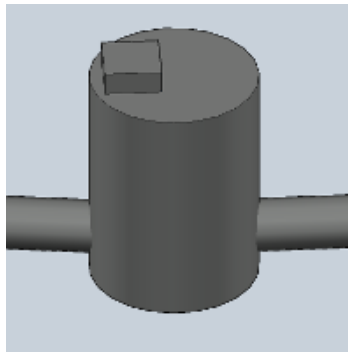

SFA7 – Type1B – Manhole (B.10)

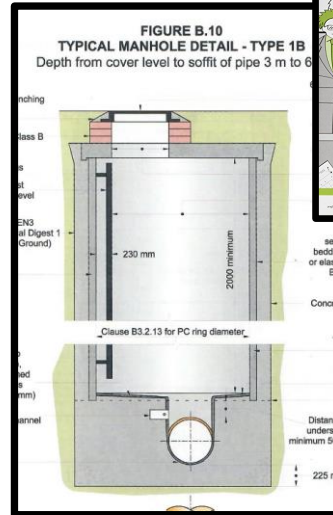



















Network Parts List - _SFAv7 - Foul Water System



















Information | Pipes | Structures | Summary



















Name	Style	Rules	Render Material	Rate Item	Structure Type
[-] _SFAv7 - Foul Water System					
[-] Null Structure					
[-] SFA7 - Type1A - 1200 access (for ladder) (B.8)					< none >
[-] SFA7 - Type1A - 1200 access (for ladder) (B.9 Alt)					< none >
[-] SFA7 - Type1A - 900 access (B.8)					< none >
[-] SFA7 - Type1A - 900 access (B.9 Alt)					< none >
[-] SFA7 - Type1B - Manhole (B.10)					< none >
[-] SFA7 - Type1B - Manhole (B.11 Alt)					< none >
[-] SFA7 - Type2 - Manhole (B.12)					< none >
[-] SFA7 - Type2 - Manhole (B.13 Alt)					< none >
[-] SFA7 - Type3 - Circ Flexible (Heavy Loads) (B.16)					< none >
[-] SFA7 - Type3 - Rect Flexible (Heavy Load) (B.16)					< none >
[-] SFA7 - Type3 - Cir Flexible (Driveways) (B.17a)					< none >
[-] SFA7 - Type3 - Circ Flexible (Gardens) (B.17b)					< none >
[-] SFA7 - Type3 - Rect Flexible (Driveways) (B.17a)					< none >
[-] SFA7 - Type3 - Rect Flexible (Gardens) (B.17b)					< none >
[-] SFA7 - Type3 - Circ Rigid (Heavy Loads) (B.18)					< none >
[-] SFA7 - Type3 - Rect Rigid (Heavy Load) (B.18)					< none >
[-] SFA7 - Type3 - Circ Rigid (Light Loads) (B.19)					< none >
[-] SFA7 - Type3 - Rect Rigid (Light Loads) (B.19)					< none >
[-] SFA7 - Type4 - Circ Flexible (Driveways) (B.21a)					< none >
[-] SFA7 - Type4 - Circ Flexible (Gardens) (B.21b)					< none >
[-] SFA7 - Type4 - Rect Flexible (Driveways) (B.21a)					< none >
[-] SFA7 - Type4 - Rect Flexible (Gardens) (B.21b)					< none >
[-] SFA7 - Type4 - Circ Flexible (Alternative) (B.22)					< none >







OK Cancel Apply Help

Similar structures are also available in the parts list ‘SFAv7 – Storm Water System’

Structure Type	Foul Plan	Storm Plan	3D Geometry
SFA7-Type1A – 1200 access (for ladder) (B.8) SFA7-Type1A – 1200 access (for ladder) (B.9 Alt)			
SFA7-Type1A – 900 access (B.8) SFA7-Type1A – 900 access (B.9 Alt)			
SFA7 – Type1B – Manhole (B.10) SFA7 – Type1B – Manhole (B.11 Alt)			
SFA7 – Type2 – Manhole (B.12) SFA7 – Type2 – Manhole (B.13 Alt)			
SFA – Type3 – Circ Flexible (Heavy Loads) (B.16)			
SFA – Type3 – Rect Flexible (Heavy Load) (B.16)			

Structure Type	Foul Plan	Storm Plan	3D Geometry
SFA7 – Type3 – Circ Flexible (Driveways) (B.17a)			
SFA – Type3 – Circ Flexible (Gardens) (B.17b)			
SFA – Type3 – Rect Flexible (Driveways) (B.17a)			
SFA – Type3 – Rect Flexible (Driveways) (B.17b)			
SFA – Type3 – Circ Rigid (Heavy Loads) (B.18)			
SFA – Type3 – Rect Rigid (Heavy Load) (B.18)			

Structure Type	Foul Plan	Storm Plan	3D Geometry
SFA – Type3 – Circ Rigid (Light Loads) (B.19)			
SFA – Type3 – Rect Rigid (Light Loads) (B.19)			
SFA – Type4 – Rect Flexible (Driveways) (B.21a)			
SFA – Type4 – Circ Flexible (Gardens) (B.21b)			
SFA7 – Type4 – Circ Flexible (Driveways) (B.21a)			
SFA – Type4 – Rect Flexible (Gardens) (B.21b)			

Structure Type	Foul Plan	Storm Plan	3D Geometry
SFA – Type4 – Circ Flexible (Alternative) (B.22)			
SFA7 – Type4 – Shallow Rect Brick (B.23)			

Overview of Structures available in the Civil 3D ‘SFA’ Parts Lists

4.7.5 Structure Designations (SFAv7)

The designation list is deliberately extensive. It is recommended that part sizes that will not be used in a scheme are removed from this list.

SFA7 - Type1A - 1200 access (for ladder) (B.8)

- [1,500 dia 750 h reducer Type 1A Manhole \(L\) \(B.8\)](#)
- [1,800 dia 750 h reducer Type 1A Manhole \(L\) \(B.8\)](#)
- [1,950 dia 750 h reducer Type 1A Manhole \(L\) \(B.8\)](#)
- [2,100 dia 750 h reducer Type 1A Manhole \(L\) \(B.8\)](#)
- [2,250 dia 750 h reducer Type 1A Manhole \(L\) \(B.8\)](#)
- [1,500 dia 450 h reducer Type 1A Manhole \(L\) \(B.8\)](#)
- [1,800 dia 450 h reducer Type 1A Manhole \(L\) \(B.8\)](#)
- [1,950 dia 450 h reducer Type 1A Manhole \(L\) \(B.8\)](#)
- [2,100 dia 450 h reducer Type 1A Manhole \(L\) \(B.8\)](#)
- [2,250 dia 450 h reducer Type 1A Manhole \(L\) \(B.8\)](#)
- [1,500 dia 1,050 h reducer Type 1A Manhole \(L\) \(B.8\)](#)
- [1,800 dia 1,050 h reducer Type 1A Manhole \(L\) \(B.8\)](#)
- [1,950 dia 1,050 h reducer Type 1A Manhole \(L\) \(B.8\)](#)
- [2,100 dia 1,050 h reducer Type 1A Manhole \(L\) \(B.8\)](#)
- [2,250 dia 1,050 h reducer Type 1A Manhole \(L\) \(B.8\)](#)
- [1,500 dia 1,350 h reducer Type 1A Manhole \(L\) \(B.8\)](#)
- [1,800 dia 1,350 h reducer Type 1A Manhole \(L\) \(B.8\)](#)
- [1,950 dia 1,350 h reducer Type 1A Manhole \(L\) \(B.8\)](#)
- [2,100 dia 1,350 h reducer Type 1A Manhole \(L\) \(B.8\)](#)
- [2,250 dia 1,350 h reducer Type 1A Manhole \(L\) \(B.8\)](#)
- [1,500 dia 1,650 h reducer Type 1A Manhole \(L\) \(B.8\)](#)
- [1,800 dia 1,650 h reducer Type 1A Manhole \(L\) \(B.8\)](#)
- [1,950 dia 1,650 h reducer Type 1A Manhole \(L\) \(B.8\)](#)
- [2,100 dia 1,650 h reducer Type 1A Manhole \(L\) \(B.8\)](#)
- [2,250 dia 1,650 h reducer Type 1A Manhole \(L\) \(B.8\)](#)

SFA7 - Type1A - 900 access (B.8)

- [1,200 dia 750 h reducer Type 1A \(B.8\)](#)
- [1,500 dia 750 h reducer Type 1A \(B.8\)](#)
- [1,800 dia 750 h reducer Type 1A \(B.8\)](#)
- [1,350 dia 750 h reducer Type 1A \(B.8\)](#)
- [1,200 dia 450 h reducer Type 1A \(B.8\)](#)
- [1,500 dia 450 h reducer Type 1A \(B.8\)](#)
- [1,800 dia 450 h reducer Type 1A \(B.8\)](#)
- [1,350 dia 450 h reducer Type 1A \(B.8\)](#)
- [1,200 dia 1,050 h reducer Type 1A \(B.8\)](#)
- [1,500 dia 1,050 h reducer Type 1A \(B.8\)](#)
- [1,800 dia 1,050 h reducer Type 1A \(B.8\)](#)
- [1,350 dia 1,050 h reducer Type 1A \(B.8\)](#)
- [1,200 dia 1,350 h reducer Type 1A \(B.8\)](#)
- [1,500 dia 1,350 h reducer Type 1A \(B.8\)](#)
- [1,800 dia 1,350 h reducer Type 1A \(B.8\)](#)
- [1,350 dia 1,350 h reducer Type 1A \(B.8\)](#)
- [1,200 dia 1,650 h reducer Type 1A \(B.8\)](#)
- [1,500 dia 1,650 h reducer Type 1A \(B.8\)](#)
- [1,800 dia 1,650 h reducer Type 1A \(B.8\)](#)
- [1,350 dia 1,650 h reducer Type 1A \(B.8\)](#)

SFA7 - Type1B - Manhole (B.10)

- [1,200 dia Type 1B Manhole \(B.10-B.11\)](#)
- [1,500 dia Type 1B Manhole \(B.10-B.11\)](#)
- [1,800 dia Type 1B Manhole \(B.10-B.11\)](#)
- [1,350 dia Type 1B Manhole \(B.10-B.11\)](#)

SFA7 - Type2 - Manhole (B.12)

- [1,200 dia Type2 \(B.12\)](#)
- [1,500 dia Type2 \(B.12\)](#)
- [1,800 dia Type2 \(B.12\)](#)
- [1,350 dia Type2 \(B.12\)](#)

SFA7 - Type1A - 1200 access (for ladder) (B.9 Alt)

- [1,500 dia 450 h reducer Type 1A Manhole \(L\) \(B.9\) Alt](#)
- [1,800 dia 450 h reducer Type 1A Manhole \(L\) \(B.9\) Alt](#)
- [1,950 dia 450 h reducer Type 1A Manhole \(L\) \(B.9\) Alt](#)
- [2,100 dia 450 h reducer Type 1A Manhole \(L\) \(B.9\) Alt](#)
- [2,250 dia 450 h reducer Type 1A Manhole \(L\) \(B.9\) Alt](#)
- [1,500 dia 750 h reducer Type 1A Manhole \(L\) \(B.9\) Alt](#)
- [1,800 dia 750 h reducer Type 1A Manhole \(L\) \(B.9\) Alt](#)
- [1,950 dia 750 h reducer Type 1A Manhole \(L\) \(B.9\) Alt](#)
- [2,100 dia 750 h reducer Type 1A Manhole \(L\) \(B.9\) Alt](#)
- [2,250 dia 750 h reducer Type 1A Manhole \(L\) \(B.9\) Alt](#)
- [1,500 dia 1,050 h reducer Type 1A Manhole \(L\) \(B.9\) Alt](#)
- [1,800 dia 1,050 h reducer Type 1A Manhole \(L\) \(B.9\) Alt](#)
- [1,950 dia 1,050 h reducer Type 1A Manhole \(L\) \(B.9\) Alt](#)
- [2,100 dia 1,050 h reducer Type 1A Manhole \(L\) \(B.9\) Alt](#)
- [2,250 dia 1,050 h reducer Type 1A Manhole \(L\) \(B.9\) Alt](#)
- [1,500 dia 1,350 h reducer Type 1A Manhole \(L\) \(B.9\) Alt](#)
- [1,800 dia 1,350 h reducer Type 1A Manhole \(L\) \(B.9\) Alt](#)
- [1,950 dia 1,350 h reducer Type 1A Manhole \(L\) \(B.9\) Alt](#)
- [2,100 dia 1,350 h reducer Type 1A Manhole \(L\) \(B.9\) Alt](#)
- [2,250 dia 1,350 h reducer Type 1A Manhole \(L\) \(B.9\) Alt](#)
- [1,500 dia 1,650 h reducer Type 1A Manhole \(L\) \(B.9\) Alt](#)
- [1,800 dia 1,650 h reducer Type 1A Manhole \(L\) \(B.9\) Alt](#)
- [1,950 dia 1,650 h reducer Type 1A Manhole \(L\) \(B.9\) Alt](#)
- [2,100 dia 1,650 h reducer Type 1A Manhole \(L\) \(B.9\) Alt](#)
- [2,250 dia 1,650 h reducer Type 1A Manhole \(L\) \(B.9\) Alt](#)

SFA7 - Type1A - 900 access (B.9 Alt)

- [1,200 dia 450 h reducer Type 1A \(B.9\) Alt](#)
- [1,500 dia 450 h reducer Type 1A \(B.9\) Alt](#)
- [1,800 dia 450 h reducer Type 1A \(B.9\) Alt](#)
- [1,350 dia 450 h reducer Type 1A \(B.9\) Alt](#)
- [1,200 dia 750 h reducer Type 1A \(B.9\) Alt](#)
- [1,500 dia 750 h reducer Type 1A \(B.9\) Alt](#)
- [1,800 dia 750 h reducer Type 1A \(B.9\) Alt](#)
- [1,350 dia 750 h reducer Type 1A \(B.9\) Alt](#)
- [1,200 dia 1,050 h reducer Type 1A \(B.9\) Alt](#)
- [1,500 dia 1,050 h reducer Type 1A \(B.9\) Alt](#)
- [1,800 dia 1,050 h reducer Type 1A \(B.9\) Alt](#)
- [1,350 dia 1,050 h reducer Type 1A \(B.9\) Alt](#)
- [1,200 dia 1,350 h reducer Type 1A \(B.9\) Alt](#)
- [1,500 dia 1,350 h reducer Type 1A \(B.9\) Alt](#)
- [1,800 dia 1,350 h reducer Type 1A \(B.9\) Alt](#)
- [1,350 dia 1,350 h reducer Type 1A \(B.9\) Alt](#)
- [1,200 dia 1,650 h reducer Type 1A \(B.9\) Alt](#)
- [1,500 dia 1,650 h reducer Type 1A \(B.9\) Alt](#)
- [1,800 dia 1,650 h reducer Type 1A \(B.9\) Alt](#)
- [1,350 dia 1,650 h reducer Type 1A \(B.9\) Alt](#)



SFA7 - Type1B - Manhole (B.11 Alt)

- [1,200 dia Type 1B \(B.11\) Alt](#)
- [1,500 dia Type 1B \(B.11\) Alt](#)
- [1,800 dia Type 1B \(B.11\) Alt](#)
- [1,350 dia Type 1B \(B.11\) Alt](#)



SFA7 - Type2 - Manhole (B.13 Alt)

- [1,200 dia Type2 \(B.13\) Alt](#)
- [1,500 dia Type2 \(B.13\) Alt](#)
- [1,800 dia Type2 \(B.13\) Alt](#)
- [1,350 dia Type2 \(B.13\) Alt](#)



SFA7 - Type3 - Circ Flexible (Heavy Loads) (B.16)

-  450 dia Type 3 (B.16)
-  500 dia Type 3 (B.16)



SFA7 - Type3 - Rect Flexible (Heavy Load) (B.16)

-  450 x 450 Type3 (B.16)
-  600 x 450 Type3 (B.16)
-  600 x 600 Type3 (B.16)







SFA7 - Type3 - Cir Flexible (Driveways) (B.17a)

-  450 dia Type3 (B.17a)
-  500 dia Type3 (B.17a)
-  600 dia Type3 (B.17a)







SFA7 - Type3 - Circ Flexible (Gardens) (B.17b)

-  450 dia Type3 (B.17b)
-  500 dia Type3 (B.17b)
-  600 dia Type3 (B.17b)



SFA7 - Type3 - Rect Flexible (Driveways) (B.17a)

-  450 x 450 Type3 (B.17a)
-  450 x 500 Type3 (B.17a)
-  450 x 600 Type3 (B.17a)
-  500 x 500 Type3 (B.17a)
-  500 x 600 Type3 (B.17a)
-  600 x 600 Type3 (B.17a)



SFA7 - Type3 - Rect Flexible (Gardens) (B.17b)

-  450 x 450 Type3 (B.17b)
-  450 x 600 Type3 (B.17b)
-  450 x 500 Type3 (B.17b)
-  600 x 600 Type3 (B.17b)
-  600 x 500 Type3 (B.17b)
-  500 x 500 Type3 (B.17b)





SFA7 - Type3 - Circ Rigid (Heavy Loads) (B.18)

-  450 dia Type3 (B.18)
-  500 dia Type3 (B.18)











SFA7 - Type3 - Rect Rigid (Heavy Load) (B.18)

-  450 x 450 Type3 (B.18)
-  450 x 600 Type3 (B.18)
-  600 x 600 Type3 (B.18)



SFA7 - Type3 - Circ Rigid (Light Loads) (B.19)

-  450.00 dia Type4 (B.19)
-  650.00 dia Type4 (B.19)
-  750.00 dia Type4 (B.19)
-  600.00 dia Type4 (B.19)









SFA7 - Type3 - Rect Rigid (Light Loads) (B.19)

-  450 x 450 Type3 (B.19)
-  600 x 450 Type3 (B.19)
-  650 x 450 Type3 (B.19)
-  750 x 450 Type3 (B.19)
-  600 x 600 Type3 (B.19)
-  650 x 600 Type3 (B.19)
-  750 x 600 Type3 (B.19)
-  650 x 650 Type3 (B.19)
-  750 x 650 Type3 (B.19)
-  750 x 750 Type3 (B.19)























SFA7 - Type4 - Circ Flexible (Driveways) (B.21a)

-  200 dia Type4 (B.21a)
-  180 dia Type4 (B.21a)
-  250 dia Type4 (B.21a)
-  280 dia Type4 (B.21a)
-  315 dia Type4 (B.21a)
-  355 dia Type4 (B.21a)
-  400 dia Type4 (B.21a)
-  450 dia Type4 (B.21a)





















SFA7 - Type4 - Circ Flexible (Gardens) (B.21b)

-  180 dia Type4 (B.21b)
-  200 dia Type4 (B.21b)
-  250 dia Type4 (B.21b)
-  280 dia Type4 (B.21b)
-  315 dia Type4 (B.21b)
-  355 dia Type4 (B.21b)
-  400 dia Type4 (B.21b)
-  450 dia Type4 (B.21b)





SFA7 - Type4 - Rect Flexible (Driveways) (B.21a)

-  100 x 225 Type4 (B.21a)
-  100 x 300 Type4 (B.21a)
-  100 x 250 Type4 (B.21a)
-  180 x 225 Type4 (B.21a)
-  180 x 300 Type4 (B.21a)
-  180 x 280 Type4 (B.21a)
-  225 x 225 Type4 (B.21a)
-  225 x 300 Type4 (B.21a)
-  225 x 350 Type4 (B.21a)
-  225 x 250 Type4 (B.21a)
-  225 x 280 Type4 (B.21a)
-  300 x 300 Type4 (B.21a)
-  300 x 350 Type4 (B.21a)
-  300 x 250 Type4 (B.21a)
-  300 x 280 Type4 (B.21a)
-  350 x 350 Type4 (B.21a)
-  350 x 250 Type4 (B.21a)
-  350 x 280 Type4 (B.21a)
-  150 x 225 Type4 (B.21a)
-  150 x 300 Type4 (B.21a)
-  150 x 250 Type4 (B.21a)
-  150 x 280 Type4 (B.21a)









SFA7 - Type4 - Rect Flexible (Gardens) (B.21b)

-  100 x 225 Type4 (B.21b)
-  100 x 250 Type4 (B.21b)
-  150 x 225 Type4 (B.21b)
-  150 x 250 Type4 (B.21b)
-  150 x 280 Type4 (B.21b)
-  150 x 300 Type4 (B.21b)
-  180 x 225 Type4 (B.21b)
-  180 x 280 Type4 (B.21b)
-  180 x 300 Type4 (B.21b)
-  225 x 225 Type4 (B.21b)
-  225 x 250 Type4 (B.21b)
-  225 x 280 Type4 (B.21b)
-  225 x 300 Type4 (B.21b)
-  300 x 250 Type4 (B.21b)
-  300 x 280 Type4 (B.21b)
-  300 x 300 Type4 (B.21b)
-  300 x 350 Type4 (B.21b)
-  350 x 250 Type4 (B.21b)
-  350 x 280 Type4 (B.21b)
-  350 x 350 Type4 (B.21b)

SFA7 - Type4 - Circ Flexible (Alternative) (B.22)

-  180 dia Type 4 Inspection Chamber (Flex)
-  225 dia Type 4 Inspection Chamber (Flex)
-  250 dia Type 4 Inspection Chamber (Flex)
-  280 dia Type 4 Inspection Chamber (Flex)

SFA7 - Type4 - Shallow Rect Brick (B.23)

-  600 x 600 Type4 Shallow (B.23)
-  600 x 700 Type4 Shallow (B.23)
-  600 x 500 Type4 Shallow (B.23)
-  700 x 700 Type4 Shallow (B.23)
-  700 x 500 Type4 Shallow (B.23)
-  500 x 500 Type4 Shallow (B.23)
-  450 x 600 Type4 Shallow (B.23)
-  450 x 700 Type4 Shallow (B.23)
-  450 x 500 Type4 Shallow (B.23)

4.7.6 Pipes (SFAv7)

A sample selection of pipes is available for use in the SFAv7 Parts Lists. Further part families and additional designations can be added as required.

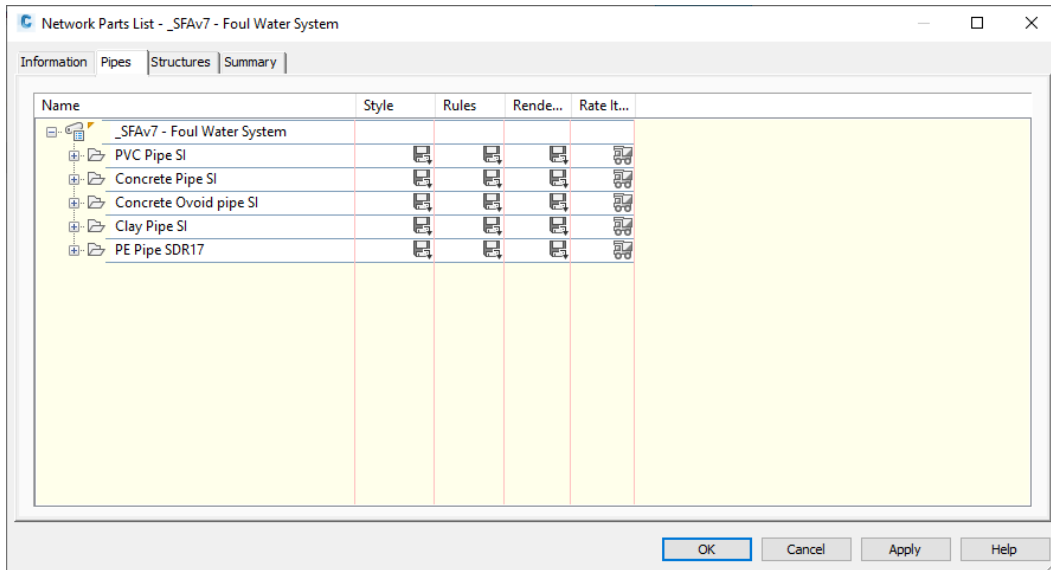

4.7.7 Pipe Designations (SFAv7)

The pipe designations included with the SFA Parts lists are not extensive. Other pipe types and sizes can be added as required.

- PVC Pipe SI
 - 100 mm PVC Pipe
 - 150 mm PVC Pipe
 - 225 mm PVC Pipe
- Concrete Pipe SI
 - 225 mm Concrete Pipe
 - 300 mm Concrete Pipe
 - 375 mm Concrete Pipe
 - 450 mm Concrete Pipe
 - 525 mm Concrete Pipe
 - 600 mm Concrete Pipe
 - 675 mm Concrete Pipe
 - 750 mm Concrete Pipe
 - 825 mm Concrete Pipe
 - 900 mm Concrete Pipe
 - 1,050 mm Concrete Pipe
 - 1,200 mm Concrete Pipe
 - 1,350 mm Concrete Pipe
 - 1,500 mm Concrete Pipe
 - 1,600 mm Concrete Pipe
 - 1,800 mm Concrete Pipe
 - 2,000 mm Concrete Pipe
 - 2,100 mm Concrete Pipe
 - 2,200 mm Concrete Pipe
 - 2,400 mm Concrete Pipe
 - 250 mm Concrete Pipe
- Concrete Ovoid pipe SI
 - 600 x 900 mm Concrete Ovoid pipe
 - 800 x 1,200 mm Concrete Ovoid pipe
 - 400 x 600 mm Concrete Ovoid pipe
- Clay Pipe SI
 - plain end 100 mm Vitrified Clay Pipe 11 mm wall thicknes
 - plain end 150 mm Vitrified Clay Pipe 14 mm wall thicknes
 - plain end 225 mm Vitrified Clay Pipe 19 mm wall thicknes
 - plain end 300 mm Vitrified Clay Pipe 29 mm wall thicknes
 - socketed 225 mm Vitrified Clay Pipe 19 mm wall thicknes:
 - socketed 300 mm Vitrified Clay Pipe 29 mm wall thicknes:
 - rocker 150 mm Vitrified Clay Pipe 11 mm wall thickness
 - rocker 225 mm Vitrified Clay Pipe 19 mm wall thickness
 - rocker 300 mm Vitrified Clay Pipe 29 mm wall thickness
 - 400 mm Vitrified Clay Pipe 46 mm wall thickness
 - 450 mm Vitrified Clay Pipe 46 mm wall thickness
 - 450 mm Vitrified Clay Pipe 51 mm wall thickness
 - 500 mm Vitrified Clay Pipe 51 mm wall thickness
 - 600 mm Vitrified Clay Pipe 58 mm wall thickness
 - Unjointed 100 mm Vitrified Clay Pipe 15 mm wall thickne:
 - Unjointed 150 mm Vitrified Clay Pipe 21 mm wall thickne:
 - Unjointed 225 mm Vitrified Clay Pipe 23 mm wall thickne:
 - Unjointed 300 mm Vitrified Clay Pipe 36 mm wall thickne:
 - 300 mm Vitrified Clay Pipe 33 mm wall thickness
 - Socketed 400 mm Vitrified Clay Pipe 46 mm wall thicknes:
 - Socketed 450 mm Vitrified Clay Pipe 46 mm wall thicknes:
- PE Pipe SDR17
 - 90 mm PE Pipe SDR17
 - 110 mm PE Pipe SDR17
 - 125 mm PE Pipe SDR17
 - 160 mm PE Pipe SDR17
 - 180 mm PE Pipe SDR17
 - 225 mm PE Pipe SDR17
 - 250 mm PE Pipe SDR17
 - 280 mm PE Pipe SDR17
 - 315 mm PE Pipe SDR17
 - 355 mm PE Pipe SDR17
 - 400 mm PE Pipe SDR17
 - 450 mm PE Pipe SDR17
 - 500 mm PE Pipe SDR17
 - 560 mm PE Pipe SDR17
 - 630 mm PE Pipe SDR17
 - 700 mm PE Pipe SDR17
 - 710 mm PE Pipe SDR17
 - 800 mm PE Pipe SDR17
 - 900 mm PE Pipe SDR17
 - 1000 mm PE Pipe SDR17

4.7.8 Pipe Styles (SFAv7)

The following pipe styles are available to aid 2D plan work.



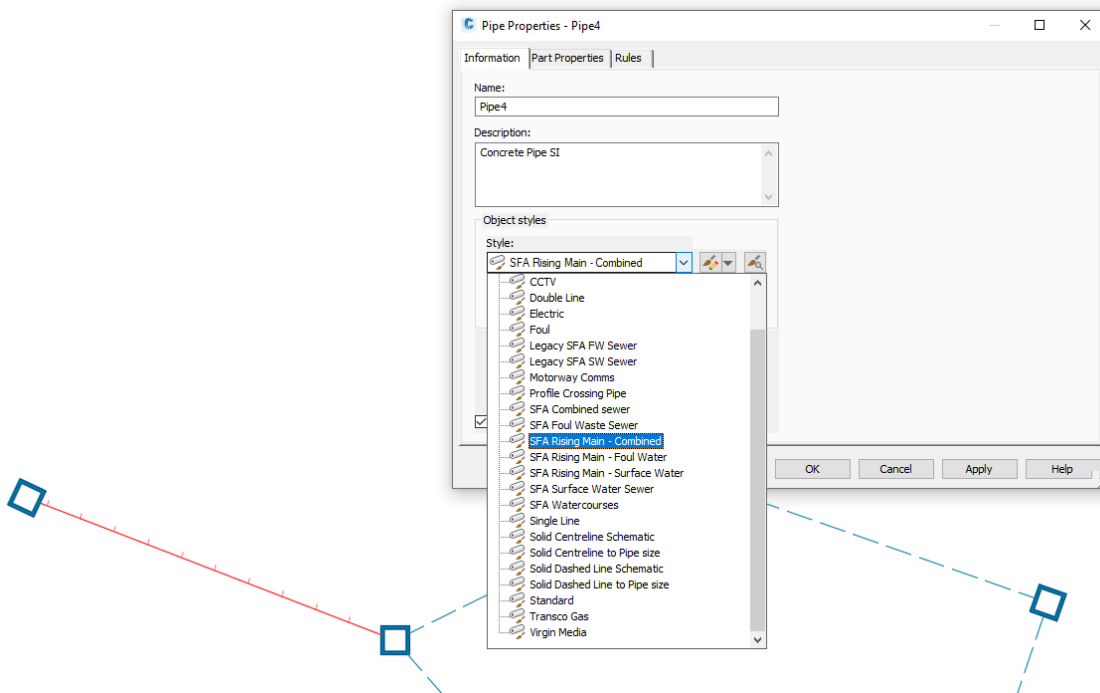







Pipe Style	2D Geometry
SFA Combined Sewer	
SFA Foul Waste Sewer	
SFA Rising Main - Combined	
SFA Rising Main – Foul Sewer	
SFA Rising Main – Surface Water	
SFA Surface Water Sewer	
SFA Watercourses	



Changing a pipe style to 'SFA Rising Main – Combined'

4.7.9 Structure Styles (SFAv7)

The following structure styles are available to aid 2D plan work:

Structure Style	2D Geometry
SFA7 – Foul Manhole Type 1-2	
SFA7 – Foul IC Type 3	
SFA7 – Foul IC Type 3 (not adoptable)	
SFA7 – Foul IC Type 4	
SFA7 – Foul IC Type 4 (not adoptable)	
SFA7 – Storm Manhole Type 1-2	
SFA7 – Storm IC Type 3	
SFA7 – Storm IC Type 3 (not adoptable)	
SFA7 – Storm IC Type 4	
SFA7 – Storm IC Type 4 (not adoptable)	

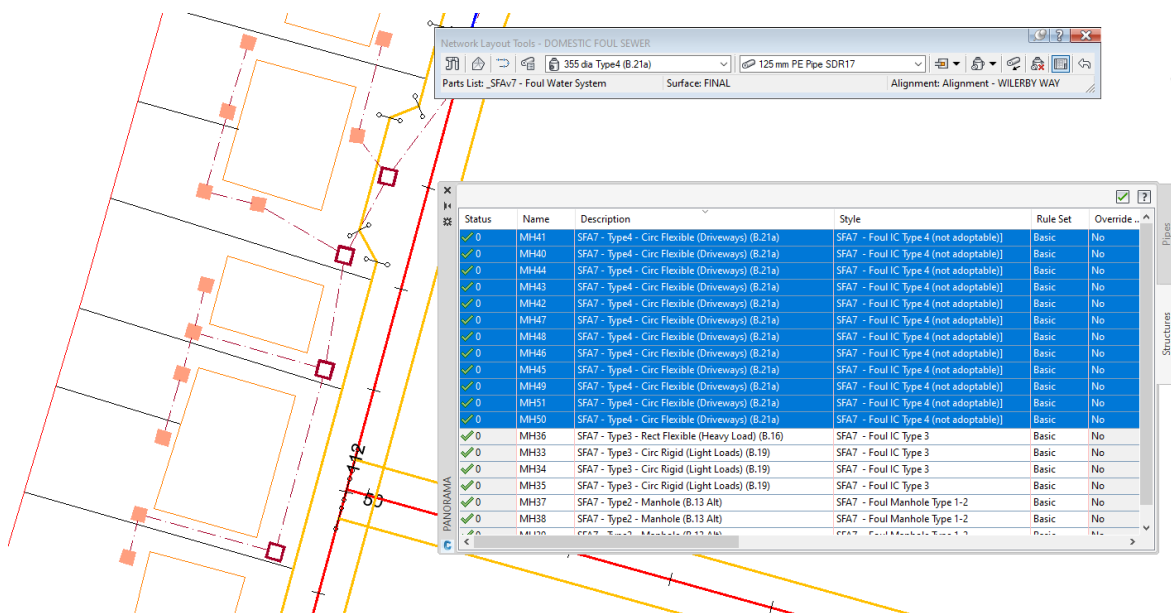

Changing the style of multiple structures to 'not adoptable' using the panorama editor

4.7.10 Pipe Rules Sets (SFAv7)

Additional Pipe rule sets have been added for SFAv7. The main point of each rule is shown in the table below:

Pipe Rule Set	Rule
Limited Access for vehicles over 7.5tonnes	Min Cover: 0.9m
No Vehicular Access	Min Cover: 0.35m
Inaccessible to vehicles over 7.5tonnes	Min Cover: 0.5m

Note: The default rule on the 'out of the box' parts list is 'Storm and Foul Drainage'. To use the rules above, they need to be applied to the pipe properties or assigned through the panorama editor.