

## COMPANY

**Federal Equipment Company**

## LOCATION

**Cincinnati, Ohio, United States**

## SOFTWARE

**Autodesk® Simulation Mechanical****Autodesk® Inventor® Professional****Autodesk® Electrical****Autodesk® Vault****Autodesk® Revit**

# U.S. Navy goes ropeless

## Federal Equipment Company designs highly innovative elevators for the U.S. Navy with help from Autodesk

The DDAM in Autodesk Simulation showed us where we needed to make fixes and where we'd overdesigned. As a result, we shaved some mass from the design, which was a plus.

**– Scott Thompson**

Mechanical Engineer  
Federal Equipment Company

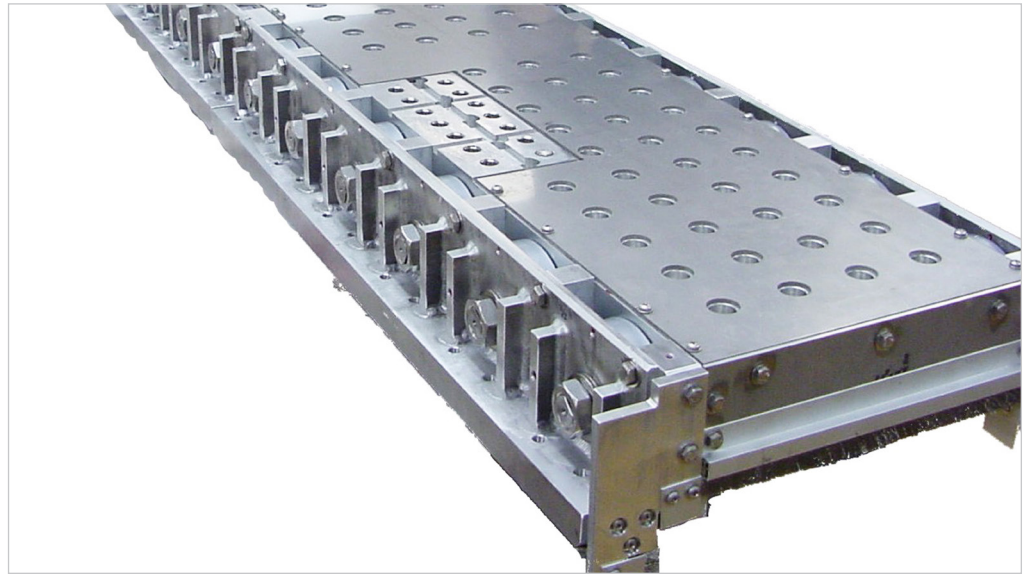

Image courtesy of Federal Equipment Company

### Project Summary

What could make a happily employed engineer leave his full-time job for a contract position in another city? "Designing an elevator that had never been built before," answers Scott Thompson, a mechanical engineer and now full-time employee at Federal Equipment Company ([www.federalequipment.com](http://www.federalequipment.com)). The Cincinnati, Ohio-based company hired Thompson to help design a completely new type of elevator—one that would operate using a vertical, synchronous motor rather than a cable-based system used by virtually every other elevator in the world. "Imagine four skateboards on the wall of the building with a platform between them," explains Thompson. "They run up and down using magnets—like those powering trains. Visualize that and you've mastered the basics of vertical synchronous motor technology. There's no rope involved."

Commissioned by the U.S. Navy, the Advanced Weapons Elevators (AWE) will ultimately carry to magazine spaces munitions that come aboard the new CVN-78 aircraft carrier. When needed, the elevators will move munitions back up to the flight deck so they can be loaded on aircraft. And the AWE will do it all using innovative linear synchronous motor technology. To develop, simulate, and optimize the groundbreaking AWE design, Thompson and his colleagues at Federal Equipment Company are relying on Digital

Prototyping and Autodesk® software, including Autodesk® Inventor® Professional and Autodesk® Simulation Mechanical. With help from Autodesk software, the team at Federal Equipment Company has been able to:

- Design AWE that move 150 feet per minute, accelerate to full speed in two seconds, and boast 200 percent more load capacity than legacy elevators
- Pass live dynamic design analysis method (DDAM) testing the first time, potentially saving hundreds of thousands of dollars
- Collaborate effectively with shipbuilder Northrop Grumman Corporation, speeding design reviews and iterations

### The Challenge

When Northrop Grumman awarded Federal the AWE US\$55 million project, it also delivered several thorny challenges for them to overcome. Doug Ridenour, president of Federal Equipment Company, explains, "The Navy had two major constraints. The load carrying capacity of each elevator had to reach 24,000 pounds with 150 percent overload capacity—more than double the capacity of legacy weapons elevators. In addition, the elevator system had to be completely ropeless."

# Analyzing models before manufacturing helps Federal optimize designs for manufacturability, reliability, strength, and cost.

## Designs that Float

One of the challenges Federal faced was finding the right balance between strength and weight. Ross Eubanks, AWE project manager at Federal, says, "Because the elevators are going into a Navy vessel, they must be designed and built like a tank. However, because it's a ship, you've got to minimize weight wherever possible."

With Inventor, the team at Federal could quickly check weight and center of gravity as they designed, letting them know the impact of their design choices. "It saved us an immeasurable amount of time," notes Thompson. "It also let us easily provide Northrop with the information it needed to control the ship's waterline."

## Getting Battle-Ready

To check whether its design met rigorous strength requirements, Federal performed initial finite element analysis (FEA) on assemblies in Autodesk Inventor Professional and more advanced FEA in Autodesk Simulation Multiphysics. Federal also relied on the DDAM capabilities in Autodesk Simulation Multiphysics to simulate the AWE model's response to shocks, such as those produced by underwater explosions. By running the DDAM simulation in Autodesk Simulation Multiphysics, the company identified potential problems before it performed the \$400,000 live tests. Thompson explains, "The DDAM in Autodesk Simulation showed us where we needed to make some fixes and where we'd overdesigned. As a result, we shaved some mass from the design, which was a plus, and passed the live test the first time."

## Easier Collaboration

Both Federal and Northrop use Autodesk Inventor software, and easily exchanged native Inventor files throughout the project. "We'd pass the data back and forth and when someone found an issue, they would shoot the data set back, pointing out the problem," says Thompson. "If a picture is worth a thousand words, a model is worth 10,000."

In addition, the collaboration facilitated by Digital Prototyping helped Federal optimize designs for manufacturability, reducing cost overruns associated with production stoppages and rework. "Digital prototypes help answer manufacturing questions before prints hit our shop floor," explains Eubanks. "By looking at the 3D model, our manufacturing team was able to suggest improvements to the design for manufacturability, which therefore decreased production costs."

## Streamlining Manufacturing

Federal has to document every last screw for the Navy, which wasn't a problem with the automatic bill of materials (BOM) functionality in Autodesk Inventor. It's helped Federal keep track of materials in assemblies comprised of thousands of parts. The company has even organized BOMs to streamline manufacturing. "We restructured our BOMs so they are in the same basic order, even though each elevator is slightly different," explains Thompson. "As a result, when manufacturing pulls the BOM into their system, it functions better."

## Results

As of February 2011, Federal has delivered two of the AWE and a third is in the shop. Production on the last of the 11 will begin within the next year. Federal credits the conceptualization and visualization capabilities in Autodesk software with facilitating design and manufacturing innovation throughout the AWE development process. In fact, the company's president believes Autodesk software has made Federal even more valuable to customers like Northrop Grumman. "Digital Prototyping helps us solve our customers' problems," Ridenour says. "As a result, we become a significant asset to them."

While Federal's president sees the advantages of Digital Prototyping from an eagle's view, the engineers on the ground appreciate how much Digital Prototyping speeds the design process and improves accuracy. "The biggest advantage from Digital Prototyping is the reuse of information. It can drastically reduce errors and design time," Thompson notes.

Federal's reliance on Autodesk software goes well beyond the AWE project. The company uses Autodesk® Revit® building information modeling (BIM) software to design heliports, finding collisions earlier in the design process and enabling collaboration with architects and engineers using BIM.

"We're definitely a big fan of Autodesk," concludes Ridenour.

## For More Information

To find out how Autodesk software and Digital Prototyping can help you explore your designs before they're built, visit

[www.autodesk.com/digitalprototyping](http://www.autodesk.com/digitalprototyping)

Autodesk Authorized Reseller Advanced Solutions has helped Federal pave the way to innovation. Thompson notes, "Advanced Solutions has helped us numerous times, especially during transitions when we upgrade or adopt new software. I've worked with a number of different software vendors, and Advanced Solutions has been wonderful, especially compared to others."

– **Scott Thompson**

Mechanical Engineer  
Federal Equipment Company

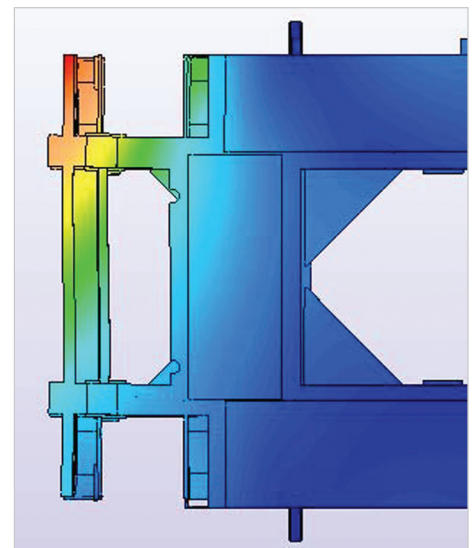

Images courtesy of Federal Equipment Company