

LEADING THE FUTURE OF BUILDING

Connecting Design and Construction



Introduction

ABOUT THIS SMARTMARKET BRIEF

BIM initially gained traction in the US marketplace with design professionals to iterate more fluidly, analyze options more objectively, and produce better documentation. As modeling has matured, an increasing number of contractors and fabricators have embraced BIM for its exceptional value in downstream activities, such as detailing, fabrication, installation and handover; integrating the complete design-to-construction workflow as an efficient, collaborative digital effort. In the report, this is referred to as the integrated workflow.

The research presented in this report focuses on the architectural, structural and MEP (mechanical, electrical, plumbing) aspects of the integrated workflow for buildings projects, examining:

- The current and future value of BIM
- How BIM is used to connect design professionals with fabricators and contractors
- The frequency of current implementation, and the current and future impacts of a fully connected, integrated workflow for buildings projects

Information about the research sample can be found in the Research Demographics section of this report.

CONTENTS

- 1 Introduction**
- 2 Perspectives on BIM**
- 7 BIM for Engineers & Trades**
- 15 Integrated Workflow for Structural & MEP**
- 22 Industry Leaders**
- 26 Key Takeaways**
- 27 Research Demographics**
- 28 Contacts & Resources**

MESSAGE FROM AUTODESK

Building Information Modeling (BIM), an intelligent model-based design process, provides a critical foundation to help designers, builders and owners leverage disruption to gain a competitive advantage with enhanced ability to access, share and make useful enormous amounts of information throughout the lifecycle of buildings and infrastructure.

BIM is blurring the lines between digital processing and physical systems, causing the design and build phases of projects to move closer together. Seamless integration of these processes save time and money. Tools used to connect design and construction include streamlined fabrication technology, prefabrication of materials offsite, modular construction and 3D printing.

Autodesk is pleased to support the research on Connecting Design and Construction presented in this report as part of the Leading the Future of Building series.

Perspectives on BIM

VALUE AND CHALLENGES OF BIM

To understand how survey participants (architects, engineers, and general and trade contractors) currently view the state of BIM in their organizations, they were asked about:

- The top ways in which BIM provides positive impacts
- The leading challenges they face in expanding their implementation of BIM

POSITIVE IMPACT OF BIM

Respondents were shown five statements about the positive impact of BIM and asked how much they agree with each (strongly agree, agree, neutral, disagree, or strongly disagree). The chart at right shows the percentages that either agree or strongly agree with each statement.

- Agreement is strong for all five value statements, especially improved collaboration and reduced rework.
- Users doing more than half their work with BIM rate all the value statements more highly than less-engaged users, reinforcing the point that greater BIM implementation generates higher experience of value.
- Risk mitigation from earlier team engagement scores lowest, but since it requires a longer time to truly measure, its positive impact can be expected to increase in coming years.

Top Values of BIM (by Level of BIM Engagement)

Percentage of high and low engagement BIM users who agree or strongly agree with each value statement

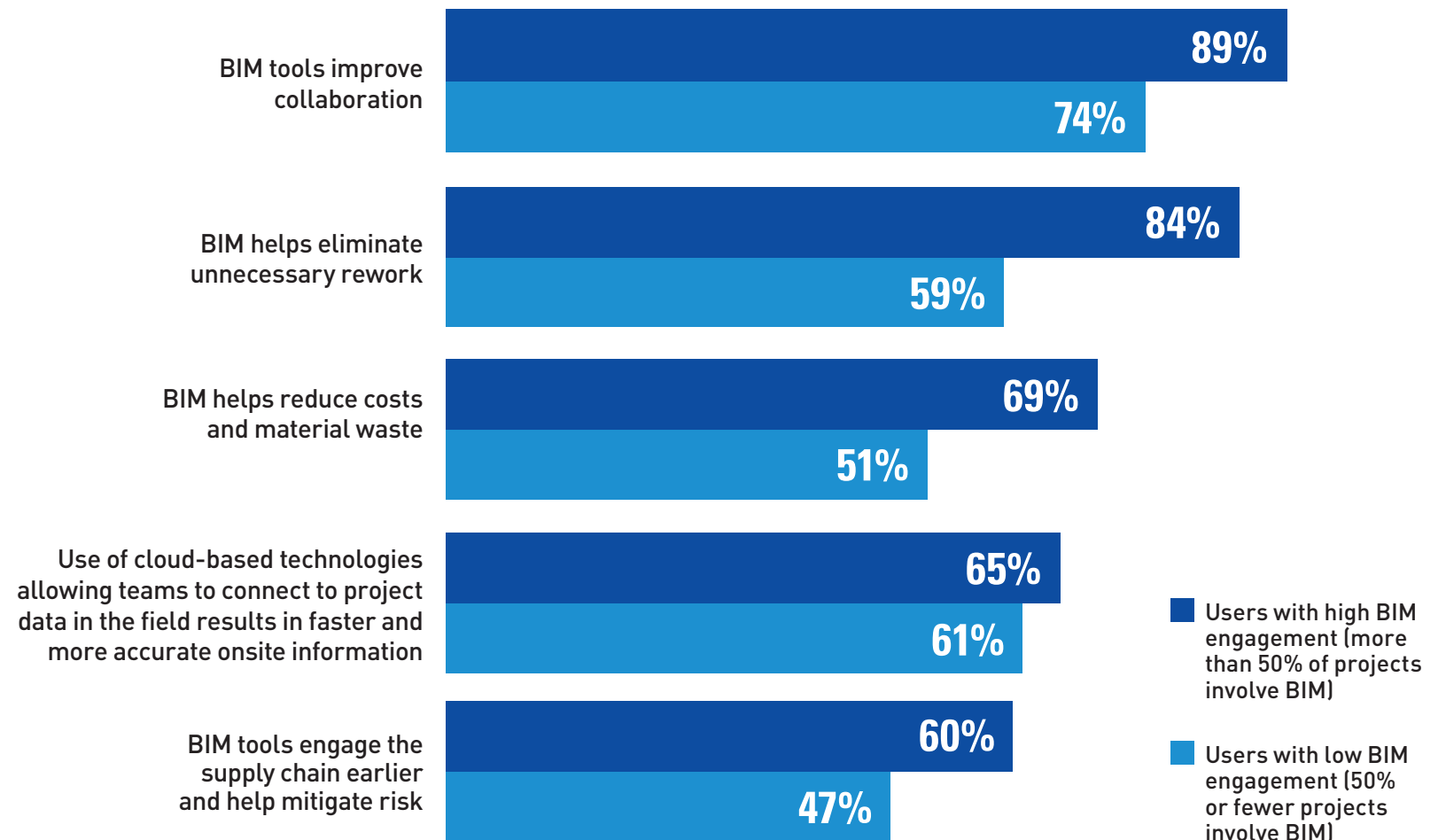

Perspectives on BIM

VALUE AND CHALLENGES OF BIM

PERSPECTIVES ON VALUE BY DISCIPLINE

To understand the varying perspectives of the different disciplines in the study, the chart at the right shows the average percentages of each respondent-type that agree or strongly agree with all five statements about the positive impact of BIM (see page 2).

DESIGN PROFESSIONALS LAG CONTRACTORS

Although structural engineers show above-average agreement, the three design disciplines as a group only average 61% agreement, versus 76% average for the three contractor-types. This variation reveals a need to better-align value propositions across the entire team, especially with MEP engineers, to encourage more integrated processes.

Top Values of BIM (by Discipline)

Percentage of each discipline that agrees or strongly agrees with all value statements

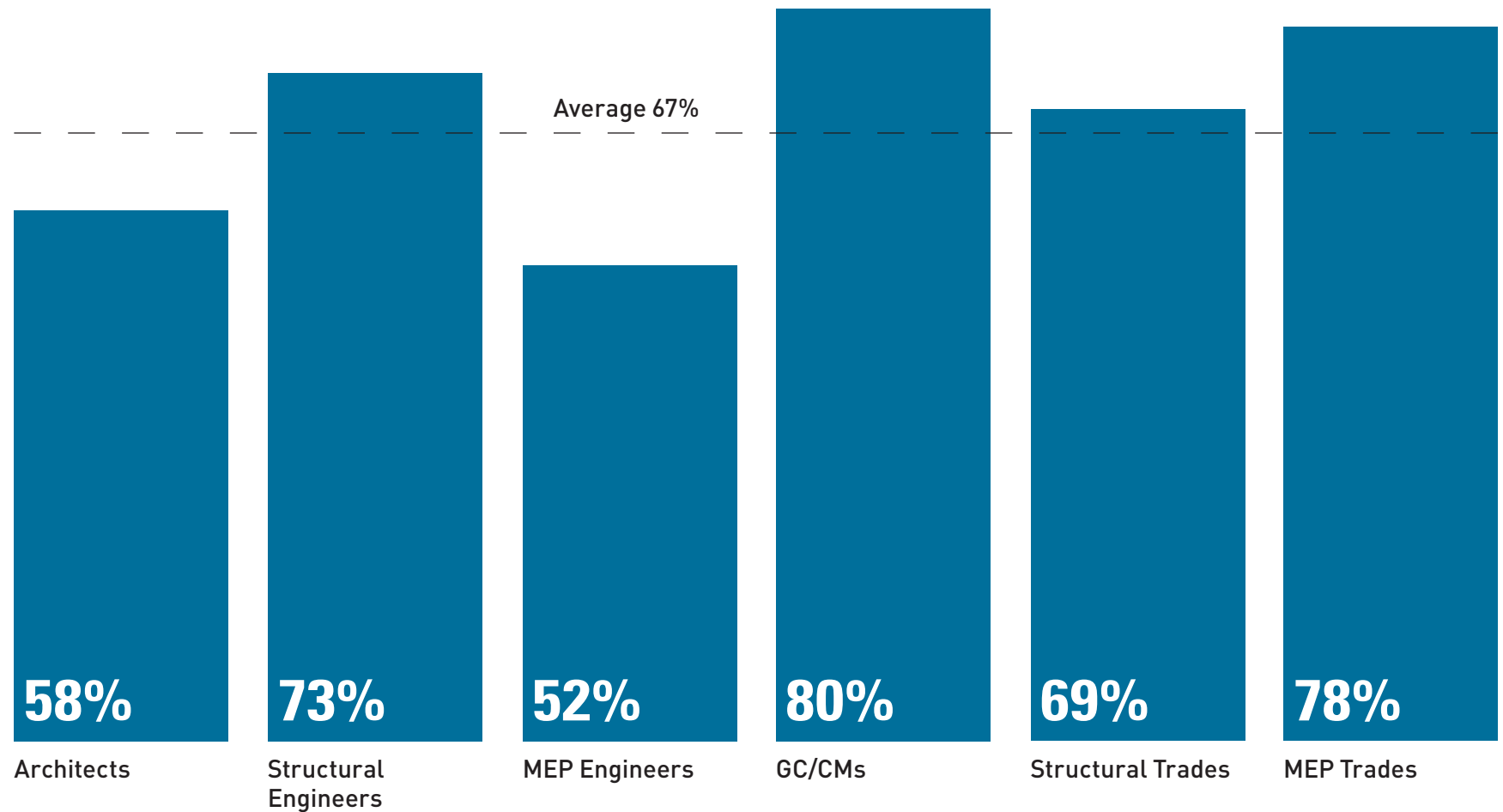

Perspectives on BIM

VALUE AND CHALLENGES OF BIM

CHALLENGES TO INCREASING BIM IMPLEMENTATION

To identify challenges users face in expanding their implementation of BIM, they were asked to rate the impact of four obstacles (Shortage of labor with BIM skills; High cost of software; Poor software interoperability; Hardware upgrades) on a five-point scale from no challenge to very high challenge. Findings are presented on this and the next page.

TOP CHALLENGE IS SHORTAGE OF STAFF WITH BIM SKILLS

The most impactful challenge cited by all types of users is the lack of labor with BIM skills.

- Interestingly, this is most true for MEP engineers, who are also least enthusiastic about the value they are currently receiving from BIM (see page 3).
- Conversely, structural engineers are least concerned about a shortage of labor with BIM skills, and are above-average in their affirmation of the positive impact of BIM.

These findings point to a correlation between having sufficient skills available and being able to receive a high level of benefit from BIM.

BIM Skill as an Obstacle to Increased BIM Implementation

Percentages of each discipline that rate shortage of labor with BIM skills as a high or very high challenge to increasing their level of BIM implementation

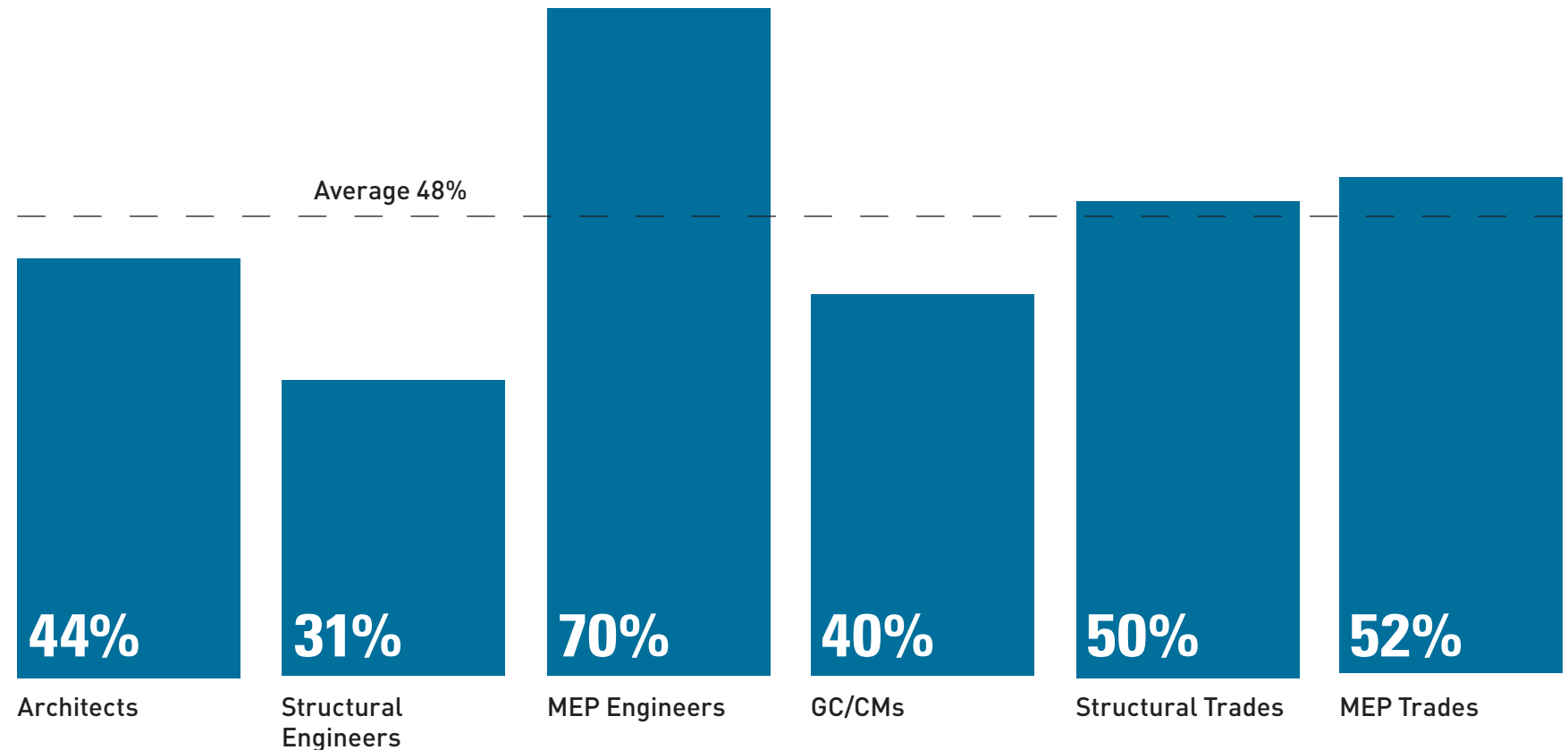

Perspectives on BIM

VALUE AND CHALLENGES OF BIM

The other three obstacles are all related to technology.

MEP ENGINEERS ARE MOST-CHALLENGED

MEP engineers, who are least enthusiastic about the current value of BIM (see page 3) and most concerned about a lack of BIM skilled staff (see page 4) are also the most challenged by software cost and hardware upgrades. These findings combine to indicate important needs for a discipline that is critical for integrated BIM workflows.

CLOUD POISED TO REDUCE OBSTACLES

The generally lower concerns for interoperability and hardware upgrades are likely to reduce even further as cloud-based functionality grows.

Technology-Related Obstacles to Increased BIM Implementation

Percentages of each discipline that rate three technology-related issues as high or very high challenges to increasing their level of BIM implementation

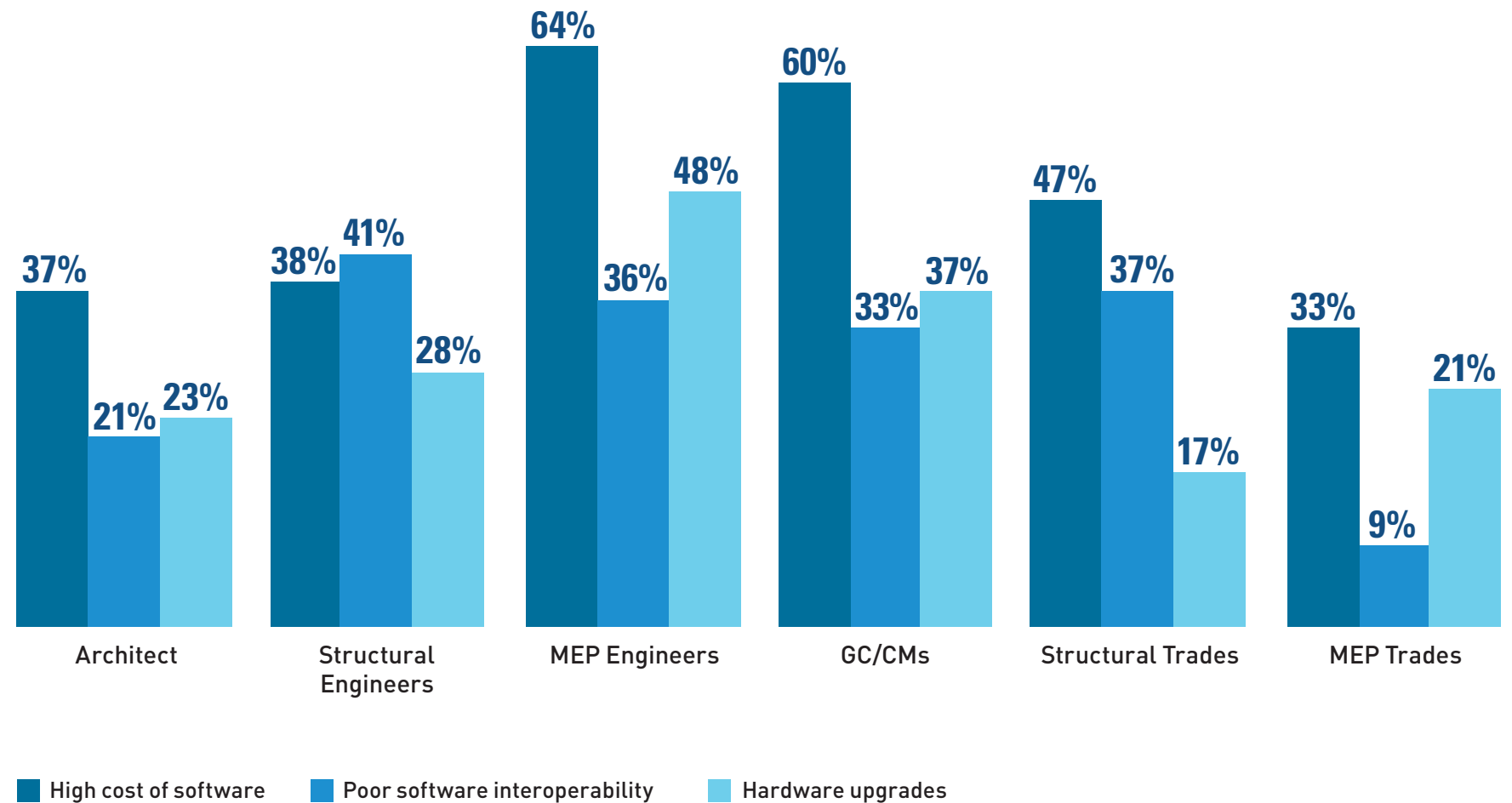

Perspectives on BIM

FUTURE IMPACT OF EMERGING BIM TRENDS AND CAPABILITIES

The matrix at right shows the percentage of each discipline that predicts high or very high positive impact for emerging BIM trends or capabilities over the next five years.

- Better, faster production of design alternatives ranks first with both designers and most builders, emphasizing its impact on the entire delivery cycle.
- Improved contract and shop deliverables, both key elements of integrated workflows, also score well.

VARIANCE BETWEEN DISCIPLINES

MEP engineers are least enthusiastic, aligning with all other findings in this part of the report. Architects are most optimistic about future capabilities, in spite of ranking next-to-last among all company types for current BIM value (see page 3).

CURRENT BIM ENGAGEMENT IMPACTS FUTURE VIEW

Respondents doing more than half their work with BIM rate the future impact of all the emerging capabilities more highly than less-engaged users, suggesting that greater BIM implementation generates higher expectations of future benefits from ongoing advancements.

Most Impactful BIM Trends and Capabilities in the Next 5 Years

Percentages of each discipline that predict high or very high positive impact for emerging BIM trends or capabilities over the next five years

	Architects	Structural Engineers	MEP Engineers	GC/CMs	Structural Trades	MEP Trades
Tools that allow visual and creative insight to produce better design alternatives in less time	83%	78%	45%	70%	70%	76%
Intelligent models that lead to more consistent and coordinated contract deliverables	77%	72%	52%	67%	67%	73%
BIM-based processes that produce better coordinated shop deliverables in less time	77%	72%	48%	73%	70%	67%
Single source of truth of project data, accessible anytime, anywhere in the office, shop or field	73%	66%	55%	53%	73%	70%
Integration of analysis and code-based design with 3D models*	63%	66%	48%	47%	53%	61%
Ability to visually simulate project delivery timelines for estimation and coordination	52%	63%	39%	53%	57%	61%

*Integration of analysis and code-based design may also be known as code-checking or design validation.

BIM for Engineers & Trades

BIM USE BY ENGINEERS, DETAILERS, FABRICATORS AND SPECIALTY CONTRACTORS

Broad industry adoption of BIM is a key requirement for the development and wide implementation of an effective integrated digital workflow for buildings projects. This section of the report addresses four key aspects related to expanding adoption and use of BIM.

BIM REQUIREMENT POLICIES BY ARCHITECTS AND GC/CM FIRMS

To understand how current BIM users are leveraging their influence in the team formation process to drive greater BIM adoption, this part of the research examines:

- Policies that architects put in place to require BIM from the engineers they retain on their design teams (structural, mechanical, electrical and civil)
- Policies that GC/CMs (general contractors and construction managers) use to require BIM capabilities from structural and MEP detailers, fabricators and specialty contractors they consider for their projects

To see the impact that respondents' current level of BIM use has

on their deployment of BIM requirement policies, these results are shown broken out into two groups:

- High BIM engagement (half or more of their current projects involve BIM)
- Low BIM engagement (fewer than half of their current projects involve BIM)

PERCEIVED LEVEL OF BIM ADOPTION BY STRUCTURAL/MEP ENGINEERS AND TRADES

The findings about BIM requirement policies are followed by architects' and GC/CMs' assessments of the current level of BIM adoption among structural/MEP engineers and trades.

BENEFITS OF BIM USE BY ENGINEERS AND TRADES

Proliferation of BIM requirements and adoption are both likely to be spurred by the measurement and publication of the tangible and repeatable benefits enjoyed by integrated project teams when engineers and trades use BIM. The third set of data in this section of the report cites:

- Architects' perspective on the positive impacts of having BIM-capable engineers on their projects
- GC/CMs' perspective on the positive impacts of having BIM-capable detailers, fabricators and specialty contractors on their projects

USE OF OUTSOURCED BIM SERVICES BY FABRICATORS

One approach to expanding BIM resources quickly in response to BIM requirements is to outsource BIM services to third parties. The fourth set of data addresses how many fabricators are currently using outsourced BIM services, and among those, what percentage are working offshore.

Architects' BIM Use Policies for Engineers

ARCHITECTS' BIM REQUIREMENTS POLICIES FOR MEP, STRUCTURAL AND CIVIL ENGINEERS

Architects were asked to identify their firm's BIM requirements policy for retaining consulting engineering firms. The chart at right compares the responses of architects at a high BIM engagement level (i.e. more than half of their current projects involve BIM) to the remaining lower-engagement firms.

BIM EXPERIENCE A KEY DRIVER FOR BIM POLICIES

The findings show that BIM experience is a key driver of demand for BIM skills on a project team.

- Highly engaged architects are much more likely to encourage and/or require BIM from MEP and structural engineers.
- Far more low-engagement architects have no BIM policy compared to their high-engagement peers.

CIVIL ENGINEERING BIM STILL EMERGING

BIM from civil engineers is still an emerging requirement for all architects, but as more infrastructure projects incorporate BIM, the capability level will increase among civil firms and their BIM skills will be in growing demand on buildings projects.

Architects' BIM Policies for Engineers

Percentages of architects reporting each of three levels of BIM requirements policy for engineering firms on their project teams

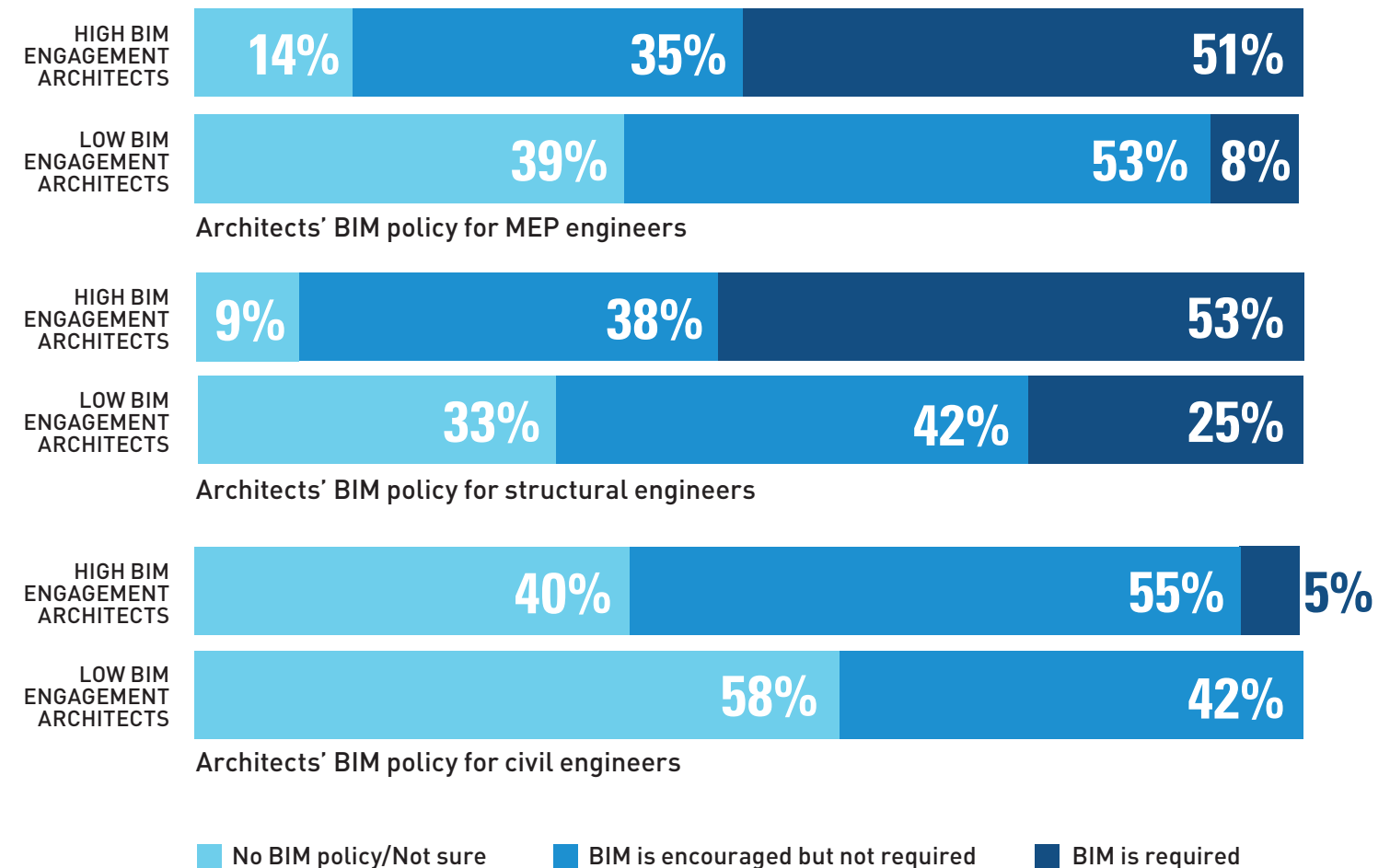

GC/CMs' BIM Use Policies for Trades (Specialty Contractors, Fabricators & Suppliers)

GC/CM BIM REQUIREMENTS POLICIES FOR MEP AND STRUCTURAL TRADES

General contractors and construction managers (GC/CMs) were asked to identify their BIM requirements policy relative to six trades (i.e. specialty contractors, fabricators) that are critical to an integrated digital workflow. Findings are presented on this and the next page. The charts compare the responses of GC/CMs at a high BIM engagement level (i.e. more than half of their current projects involve BIM) to the remaining lower-engagement GC/CMs.

GC/CM BIM REQUIREMENTS FOR MEP TRADES

High-engagement GC/CMs are even more emphatic than high-engagement architects in requiring BIM for MEP, and zero percent report having no policy. This reveals the ever-increasing importance of leveraging models for integrated MEP workflows.

Most low-engagement GC/CMs are at least encouraging BIM use by MEP trades, and requirements can be expected to grow as their BIM engagement increases.

GC/CMs' BIM Policies for MEP Trade Contractors

Percentages of GC/CMs reporting each of three levels of BIM requirements policy for MEP trade contractors on their project teams

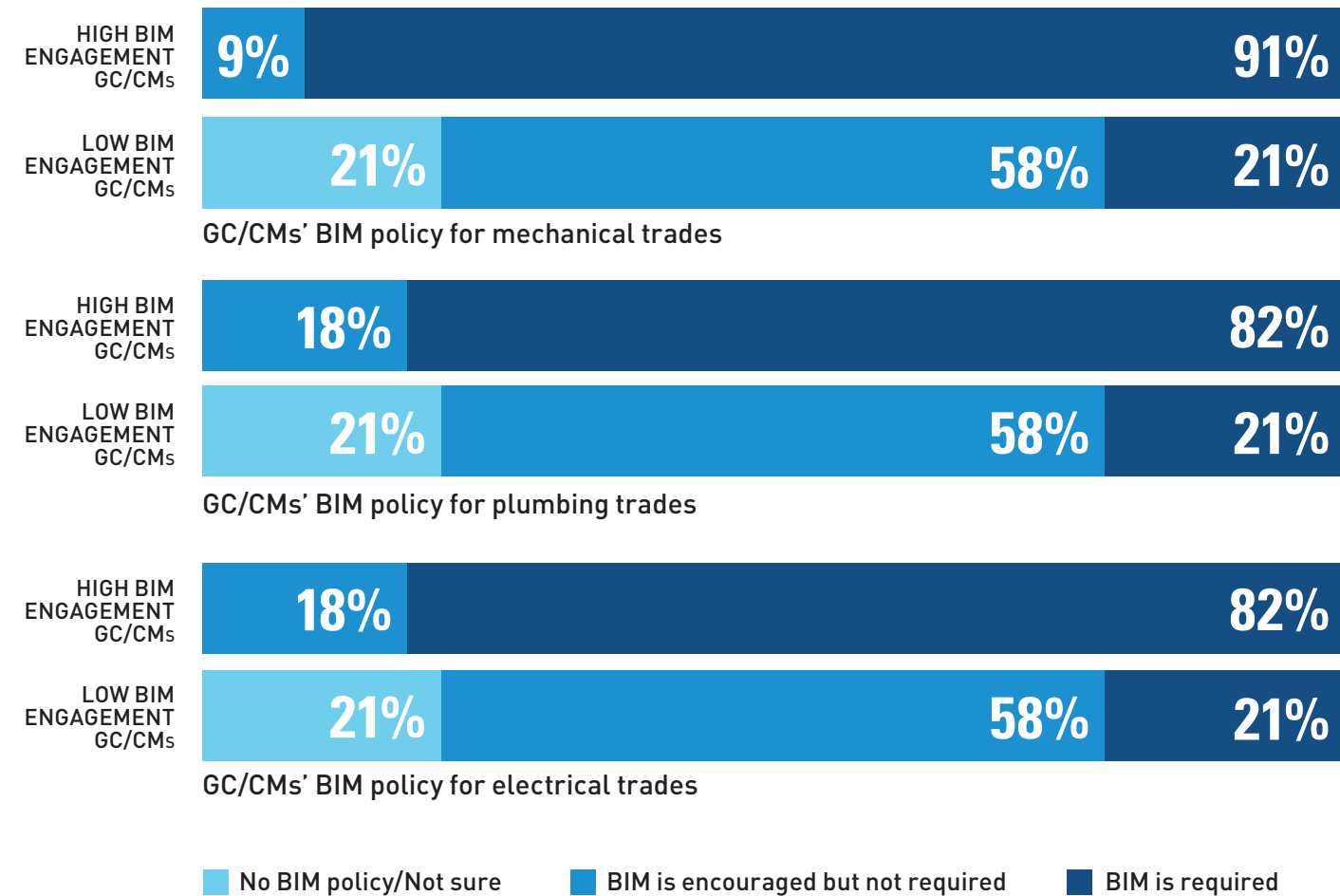

GC/CMs' BIM Use Policies for Trades (Specialty Contractors, Fabricators & Suppliers)

GC/CM BIM REQUIREMENTS POLICIES FOR MEP AND STRUCTURAL TRADES

GC/CM BIM REQUIREMENTS FOR STRUCTURAL TRADES

Although the majority (64%) of high-engagement GC/CMs require BIM from steel trades, and zero percent have no BIM policy, far fewer contractors at either engagement level are applying BIM requirement policies to concrete-related firms.

STANDARDS EXPECTED TO SPUR GROWTH

Pioneering work by the American Institute of Steel Construction (aisc.org) on developing BIM standards for steel has successfully accelerated implementation and significantly contributed to the growth of BIM requirements policies. Work is currently underway on BIM standards for concrete. These are likely to make a similarly powerful impact on engaging both designers and trades with BIM, and increase the frequency of BIM requirements throughout the supply chain.

GC/CMs' BIM Policies for Structural Trade Contractors

Percentages of GC/CMs reporting each of three levels of BIM requirements policy for structural contractors on their project teams

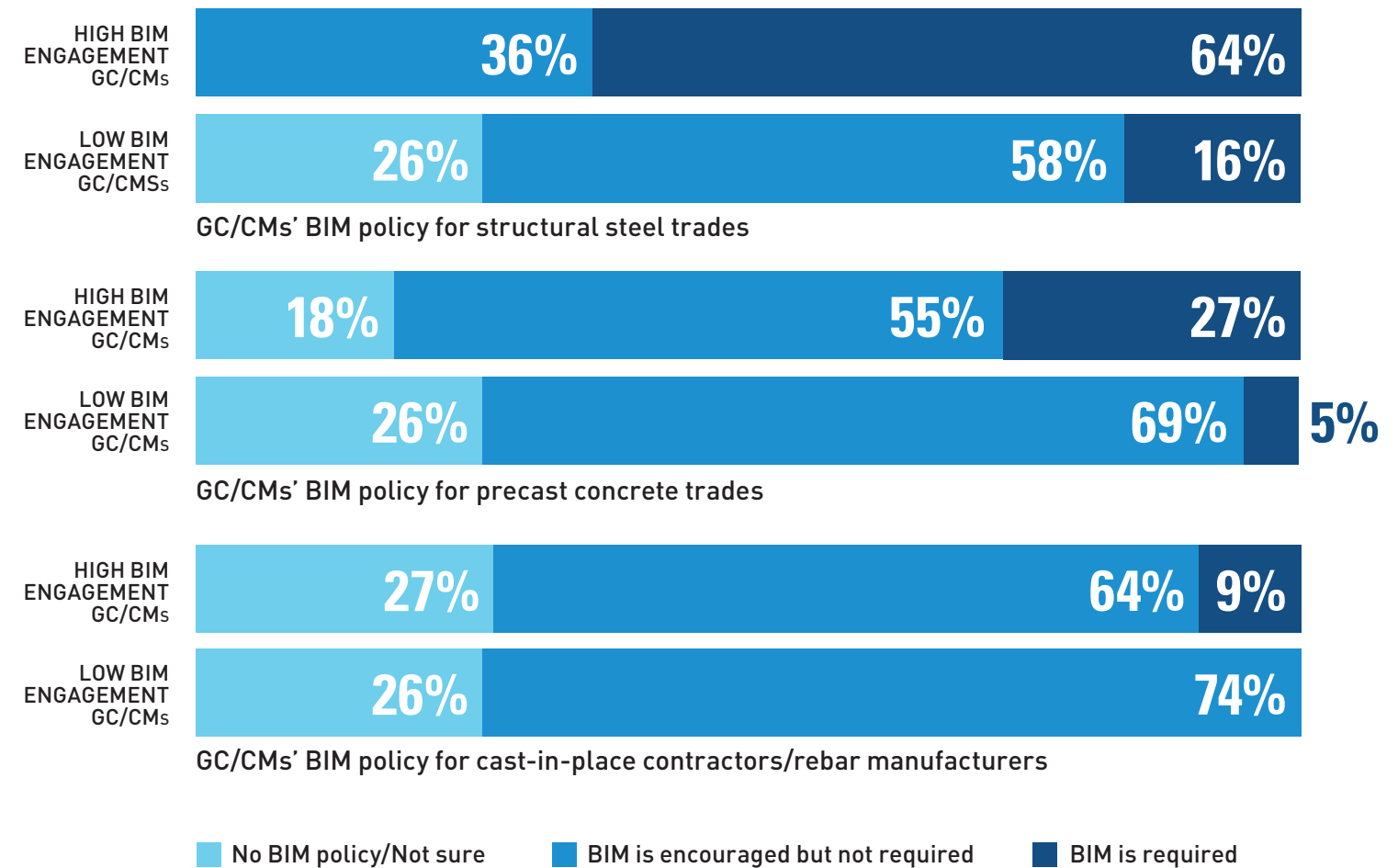

Architects' Perceived Level of BIM Adoption Among Engineers

ARCHITECTS' PERCEPTION OF BIM ADOPTION BY MEP, STRUCTURAL AND CIVIL ENGINEERS

Architects were asked about the level of BIM adoption they perceive among five types of engineering firms. The chart at right shows the percentages who perceive BIM adoption at one of three levels:

- No firms have adopted BIM (or they did not know).
- A low or medium number of firms have adopted BIM.
- A high or very high number of firms have adopted BIM.

Architects believe far more structural engineers are using BIM than the other disciplines, perhaps because of the length of time many of those firms have been working in various 3D design formats.

While very few architects report that no MEP engineers use BIM, many still indicate a low/medium adoption. This aligns with other findings in this study about MEP engineers and demonstrates a need to encourage deeper engagement by this group in order to optimize integrated workflows.

As with BIM policies, civil engineer engagement lags MEP and structural. This should improve as BIM skills become more widely entrenched in all civil realms.

Architects' Perception of BIM Adoption by Engineers

Percentage of architects who perceive each of three levels of BIM adoption in their market among five types of engineering firms

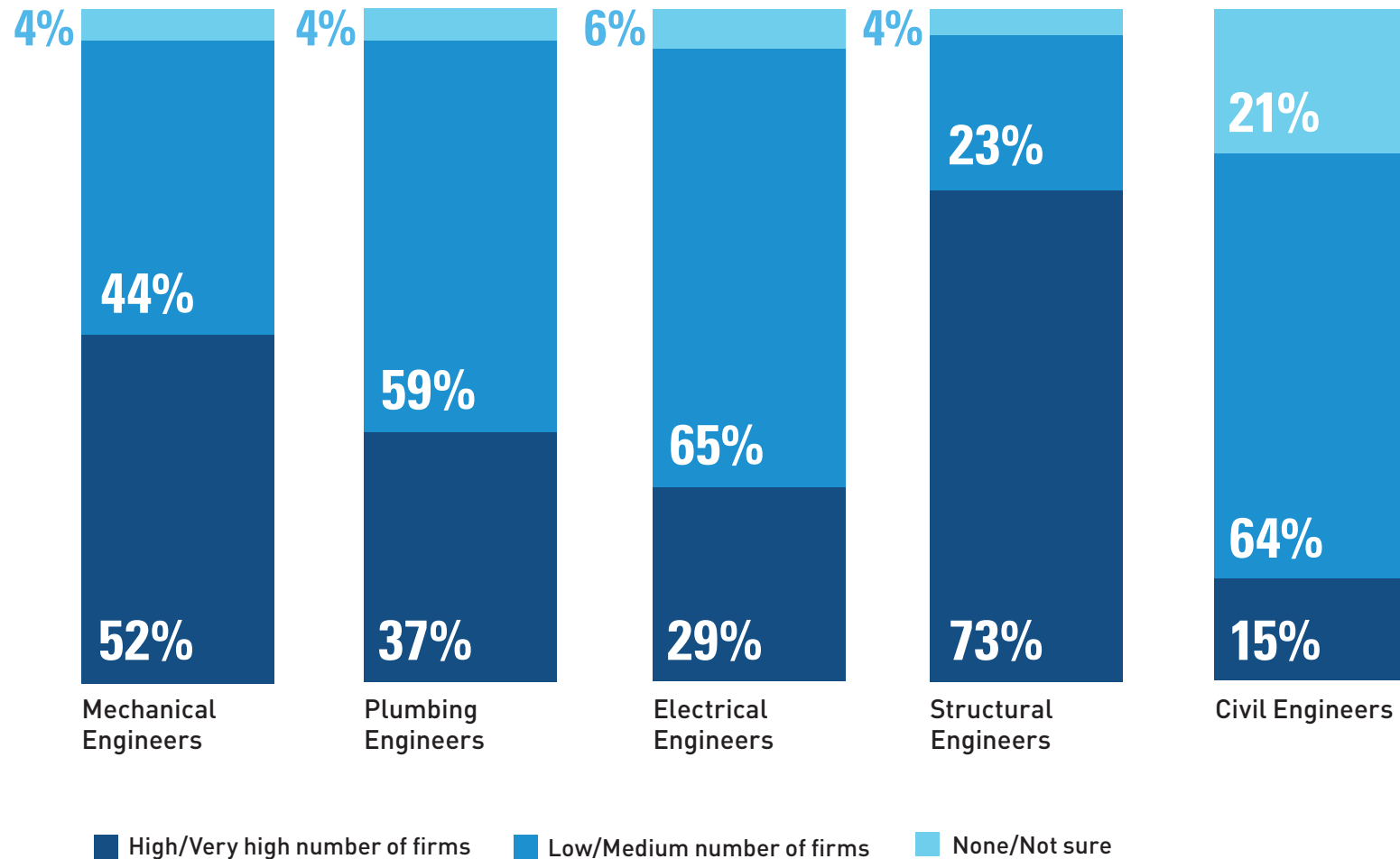

GC/CMs' Perceived Level of BIM Adoption Among MEP and Structural Trades

GC/CM PERCEPTION OF BIM ADOPTION BY MEP AND STRUCTURAL TRADES

General contractors and construction managers (GC/CMs) were asked for their perception about the level of BIM adoption among six types of trades in the areas where they build projects. The chart at right shows the percentages who perceive BIM adoption at one of three levels:

- No companies have adopted BIM (or they did not know).
- A low or medium number of companies have adopted BIM.
- A high or very high number of companies have adopted BIM.

GC/CMs perceive that mechanical contractors lead among trades for BIM adoption. This aligns with the finding that 91% of high-engagement GC/CM's require BIM from mechanical trades (see page 9).

The plumbing, electrical and structural steel trades do not lag far behind, with only a small fraction of GC/CMs citing no BIM capability for these specialties in their markets.

Much less adoption is perceived in both trade categories related to concrete. BIM standards currently under development will generate more integrated design and fabrication, thereby increasing demand and adoption.

GC/CMs' Perception of BIM Adoption by Trades

Percentage of GC/CMs who perceive each of three levels of BIM adoption in their market among six types of MEP and structural trades

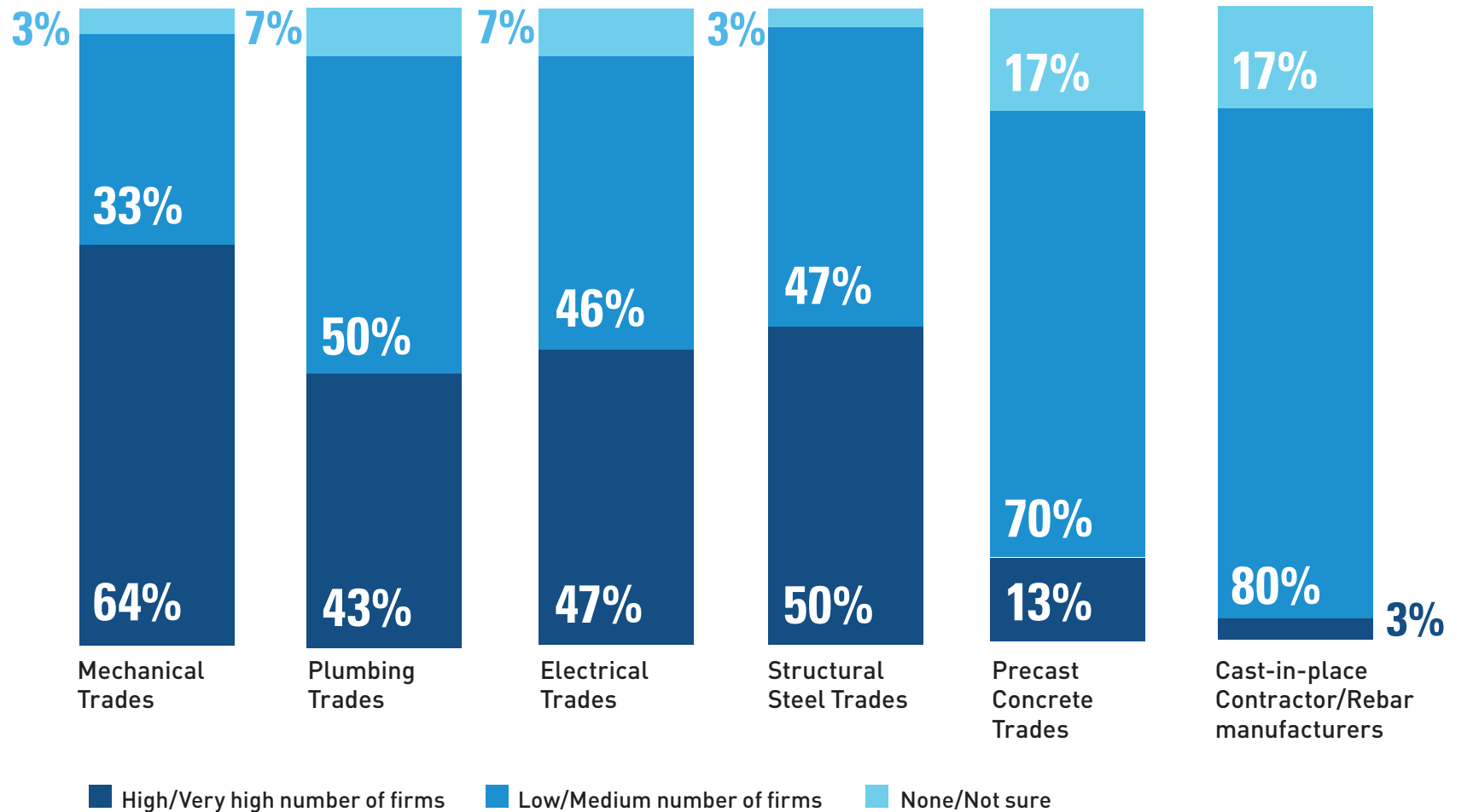

Improved Project Outcomes When BIM is Used by Engineers and Trades

BENEFITS RECEIVED BY ARCHITECTS AND GC/CMs BECAUSE OF BIM USAGE BY ENGINEERS AND TRADES

High engagement architects and GC/CMs (i.e. engaged with BIM on more than half of their projects) were asked to identify which of five benefits they receive at either a high or very high level due to other team members also being engaged with BIM.

- GC/CM's are unanimous in their top rating of improved onsite coordination of materials and installation when trades use BIM. This practical benefit can reduce waste and rework, and improve materials management and productivity. Architects also score it as the most impactful benefit of engineers using BIM, validating the importance of virtual systems coordination.
- Following close behind for engineer BIM use is improved building quality and performance, a coveted goal for design professionals, and also second-highest rated by GC/CMs.
- Cost and schedule improvements also score well with two thirds of GC/CMs, reflecting the improved efficiency of project execution that is possible with integrated BIM workflows.
- Safety is still an emerging benefit but is likely to improve, especially as BIM enables more off-site prefabrication.

Benefits of BIM (High Engagement Users Only)

Percentage of highly engaged BIM users who cite each of five benefits generated by having other key team members engaged with BIM

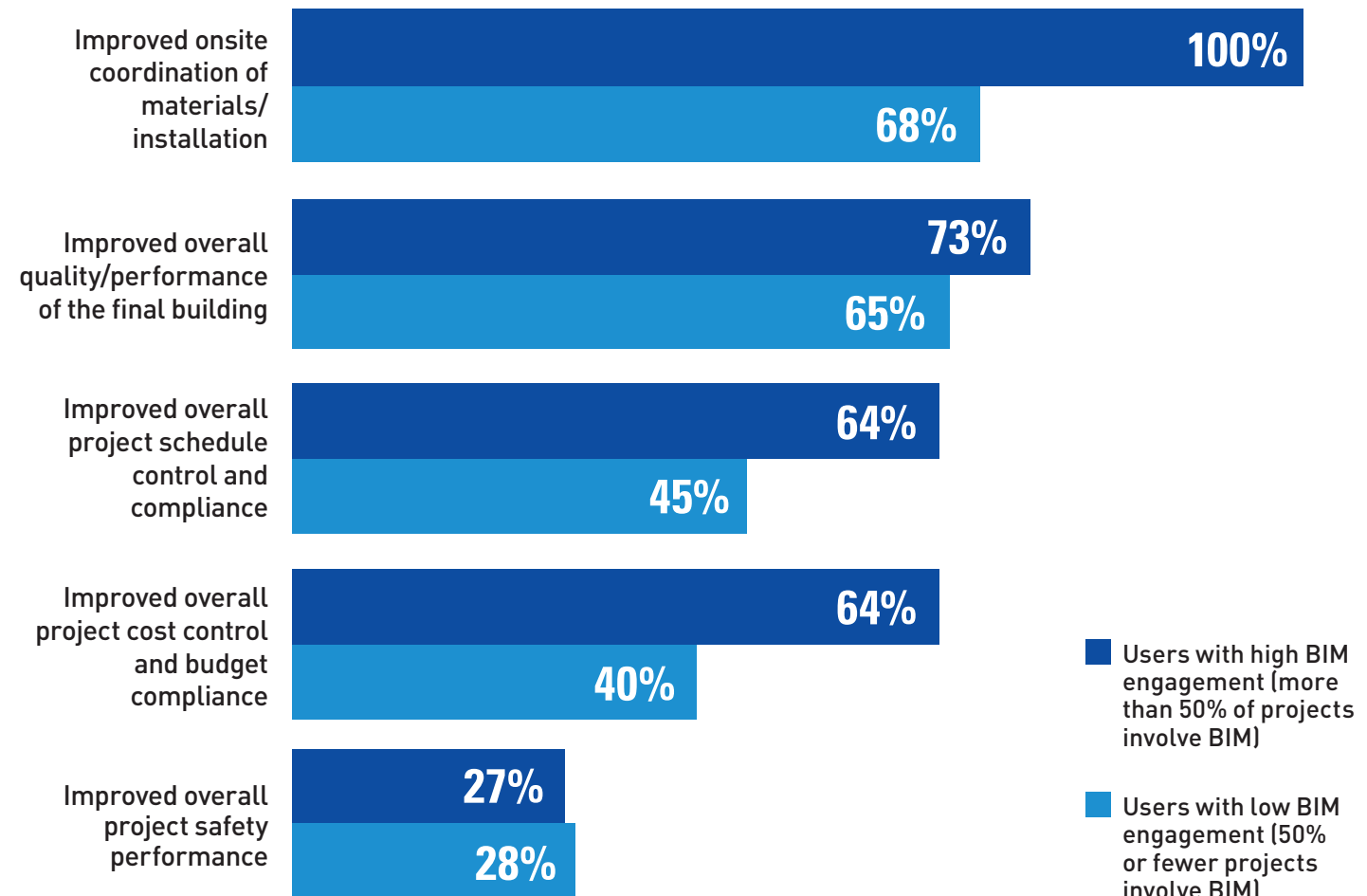

Outsourcing of BIM Work by MEP and Structural Trades

USE OF OUTSORCED BIM SERVICES BY STRUCTURAL AND MEP DETAILERS, FABRICATORS, CONTRACTORS

Access to labor with adequate BIM skills is a major challenge for structural and MEP trades (see page 4). As a potential alternative, these companies were asked how frequently they use outsourced BIM services. The chart at upper right shows their responses, comparing trades at a high level of BIM engagement (i.e. more than half of their current projects involve BIM) to the remaining, currently lower engagement ones.

That analysis shows significantly more low engagement trades using outsourced BIM services, which makes sense considering the time and resources required to recruit and nurture internal BIM capabilities.

OFFSHORE RESOURCES FOR OUTSOURCING

Overall, 63% of the trades surveyed report doing some amount of outsourcing. These companies were asked a follow-up question about how much of that work is done through offshore resources. The chart at lower right shows their responses.

- While 95% of respondents using outsourcing rely on some offshore resources, 67% are doing more than half, and among those, the majority are doing less than a quarter.
- Analysis of the respondents by their BIM engagement level does not reveal a significant difference in this basic pattern.

Frequency of BIM Outsourcing (by BIM Engagement Level)

Percentage of structural and MEP trades that outsource BIM work

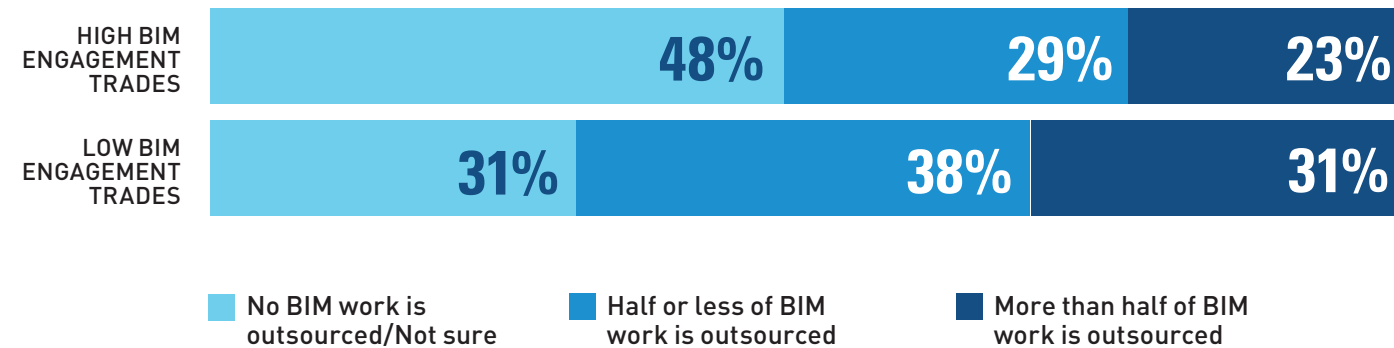

Frequency of BIM Outsourcing to Offshore Resources

Percentage of structural and MEP trades that outsource BIM and that use offshore resources

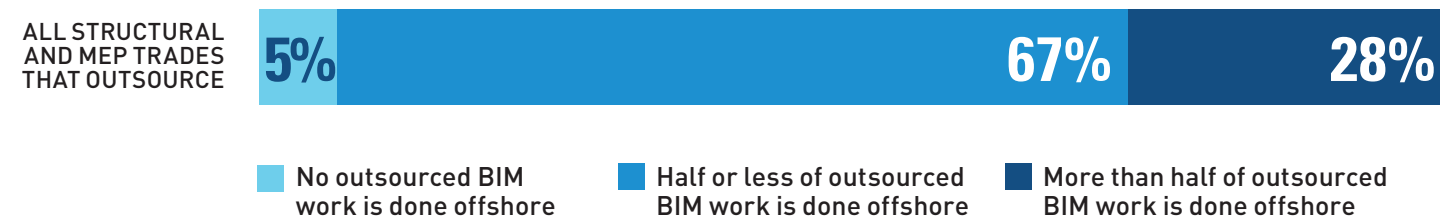

Integrated Workflow for Structural & MEP

DESIGN DETAILING, FABRICATION AND INSTALLATION

This section of the report focuses on the integrated workflow for structural and MEP systems, which is based on the sharing of model information throughout the design, detailing, fabrication and installation stages to enhance project communication and documentation.

DEFINITION OF THE INTEGRATED WORKFLOW

The integrated workflow, as defined for the purposes of this research, involves four key sets of coordinated, multi-party activities:

- It starts with engineers using the 3D design model to create a 3D structural or MEP model. Engineers use modeling tools to perform code check and analysis to ensure an optimized design. They also produce design documents and coordinate the design with other disciplines.

- This model is then shared with detailers, who generate shop drawings and erection/installation plans.
- As the integrated workflow continues, NC files, shop drawings and reports are automatically transferred into a fabricator's Material Information System (MIS) for shop floor production and shipping activities.
- To complete the integrated workflow, the detailer's 3D model is transferred back into the design model and used by installers at the jobsite to validate accuracy and confirm installation activities.

At any time during this process, the 3D model may be shared back and forth between disciplines for review and revision to ensure a clear understanding both upstream and downstream in the process.

RESEARCH ABOUT THE INTEGRATED WORKFLOW

For this research, GC/CMs (general contractors and construction managers) and the engineers and trades (structural and MEP) were asked about:

- **Frequency:** How frequently they engage in the integrated workflow on their current and recent projects
- **Phase-Specific Benefits:** The benefits of the integrated workflow on specific project phases:
 - *Design, detailing and fabrication*
 - *Installation and handover*
 - *Project performance outcomes*
- **Future Benefits:** What they believe will be the most impactful benefits of the integrated workflow in the future

Integrated Workflow: Frequency of Implementation

FREQUENCY AND LEVEL OF ENGAGEMENT WITH THE INTEGRATED WORKFLOW FOR STRUCTURAL AND MEP

To determine the penetration of the integrated workflow, GC/CMs, and structural and MEP engineers and trades were asked to identify the percentage of recent and current projects where the relevant project team companies were “engaged to some degree.” Those who say it is more than 50% of their projects were asked on what percentage of their projects the relevant companies were “fully or nearly fully engaged” with the integrated workflow.

With the responses divided by company-type, the chart at right shows that overall, MEP has the greatest engagement.

- 100% of MEP trade firms do at least some level of the integrated workflow, and 36% report full/nearly full workflow on over half of their work.
- 24% of MEP engineers report full/nearly full engagement over half the time.

34% of structural engineers report full/nearly full integration versus just 20% of structural trades, who also have the highest level of no integration (23%). This category may be impacted by the relatively low use of BIM for concrete.

GC/CMs currently show the most respondents (77%) in the “some level/less than half the time” tier, but fewest in full/nearly full (16%). This should increase as more benefits are quantified.

Frequency of Integrated Workflow

Percentage of GC/CMs, and of structural and MEP engineers and trade contractors who report participating in several levels of workflow integration on their current and recent projects

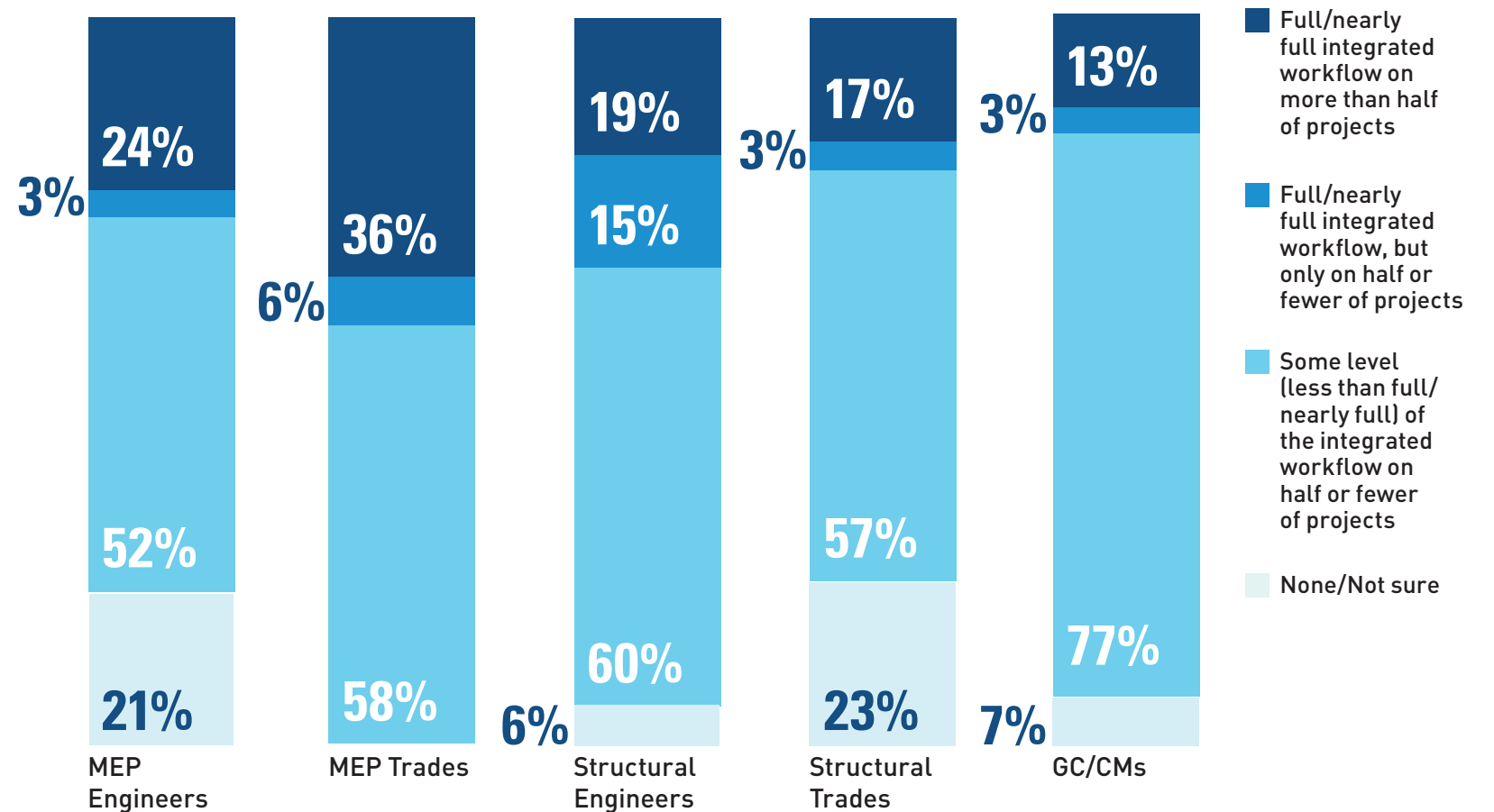

Integrated Workflow: Impact on Design, Detailing and Fabrication

IMPACT OF THE INTEGRATED WORKFLOW ON DESIGN, DETAILING AND FABRICATION FOR STRUCTURAL AND MEP

GC/CMs, and structural and MEP engineers and trades rated the positive impact of the integrated workflow on seven specific aspects of the design, detailing and fabrication workflow.

The percentages in the chart at right are just the high or very high (i.e. 4 or 5 on a scale of 5) impact ratings across all respondent types. The average percentage of those ratings across all seven design, detailing and fabrication impacts is 55%.

- The above-average ratings for improved communication, and faster/better coordinated designs and shop drawings suggest that the integrated workflow should generate those benefits for any team that engages with it.
- The other four benefits can be categorized as still maturing, but with the lowest rating at a respectable 42%, each is certainly achievable.

BIM ENGAGEMENT INCREASES PERCEPTION OF IMPACT

Users at a high level of BIM engagement (over half of their projects involve BIM) are well above the average for improved communication (82%), and faster/better coordinated shop drawings (66%).

Impact on Design, Detailing and Fabrication

Percentage of high or very high impact ratings for seven positive impacts of the integrated workflow on design, detailing and fabrication

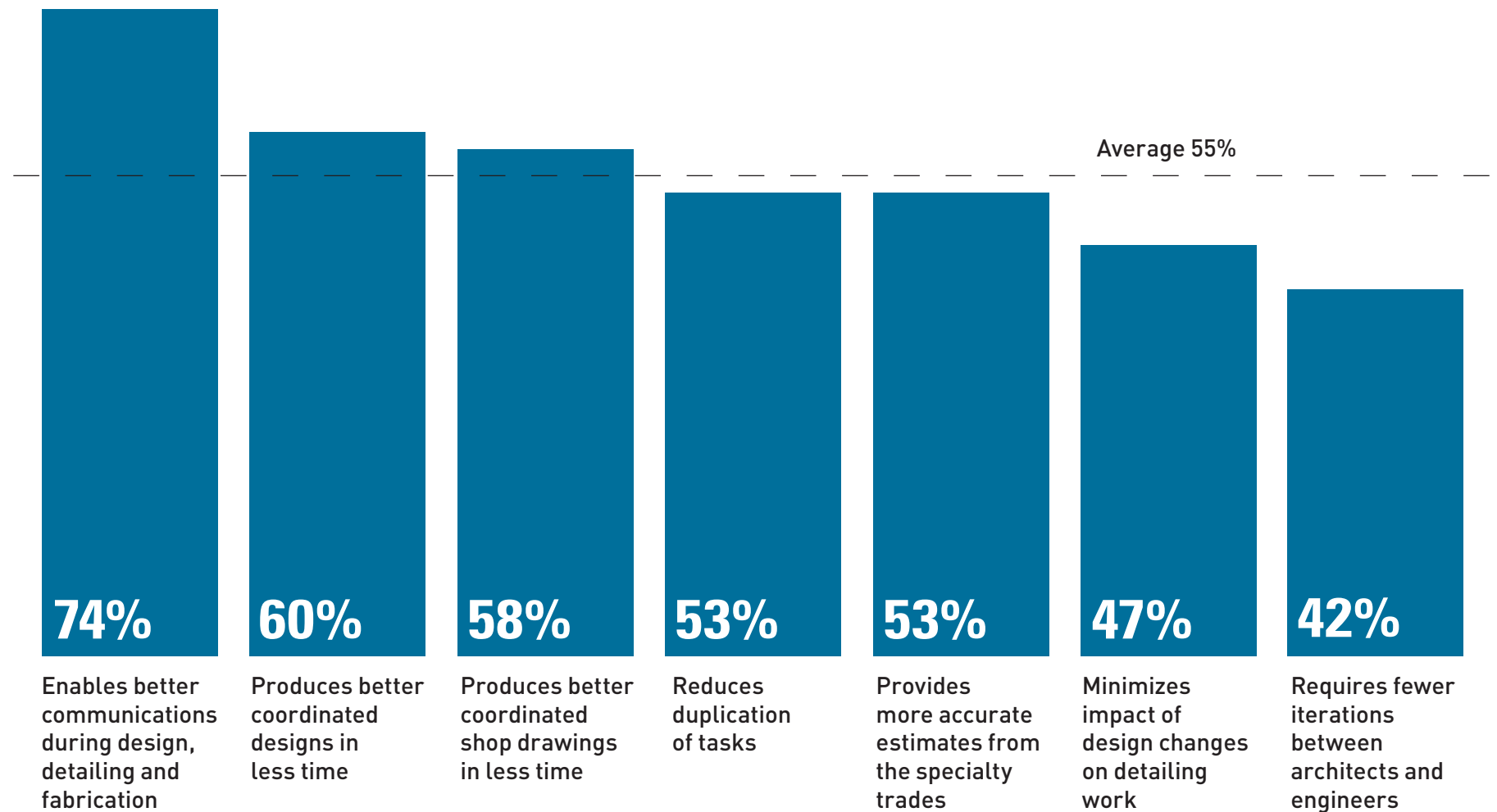

Integrated Workflow: Impact on Installation and Handover

IMPACT OF THE INTEGRATED WORKFLOW ON INSTALLATION AND HANDOVER FOR STRUCTURAL AND MEP

The GC/CMs, engineers and trades also rated the positive impact of the integrated workflow on three benefits related to installation of work and handover of the project to the client.

The percentages in the chart at right are totals of the high or very high impact ratings across all respondents. The average percentage of those ratings across all three installation and handover impacts is 39%.

- The majority of respondents cite fewer field installation errors as a top benefit, which has enormous implications for reducing rework and material waste, as well as improving productivity and schedule compliance. MEP trades (88%) are especially enthusiastic, although interestingly, MEP engineers are least so (38%).
- 55% of MEP trades give a top rating to field material updates and as-builts for client handover. Their support should encourage other trades to follow.
- Although a significant percentage of MEP trades (39%) acknowledge it, improved safety, as shown elsewhere in this report (see page 13), is still an emerging benefit.

Impact on Installation and Handover

Percentage of high or very high impact ratings for three positive impacts of the integrated workflow on installation and handover

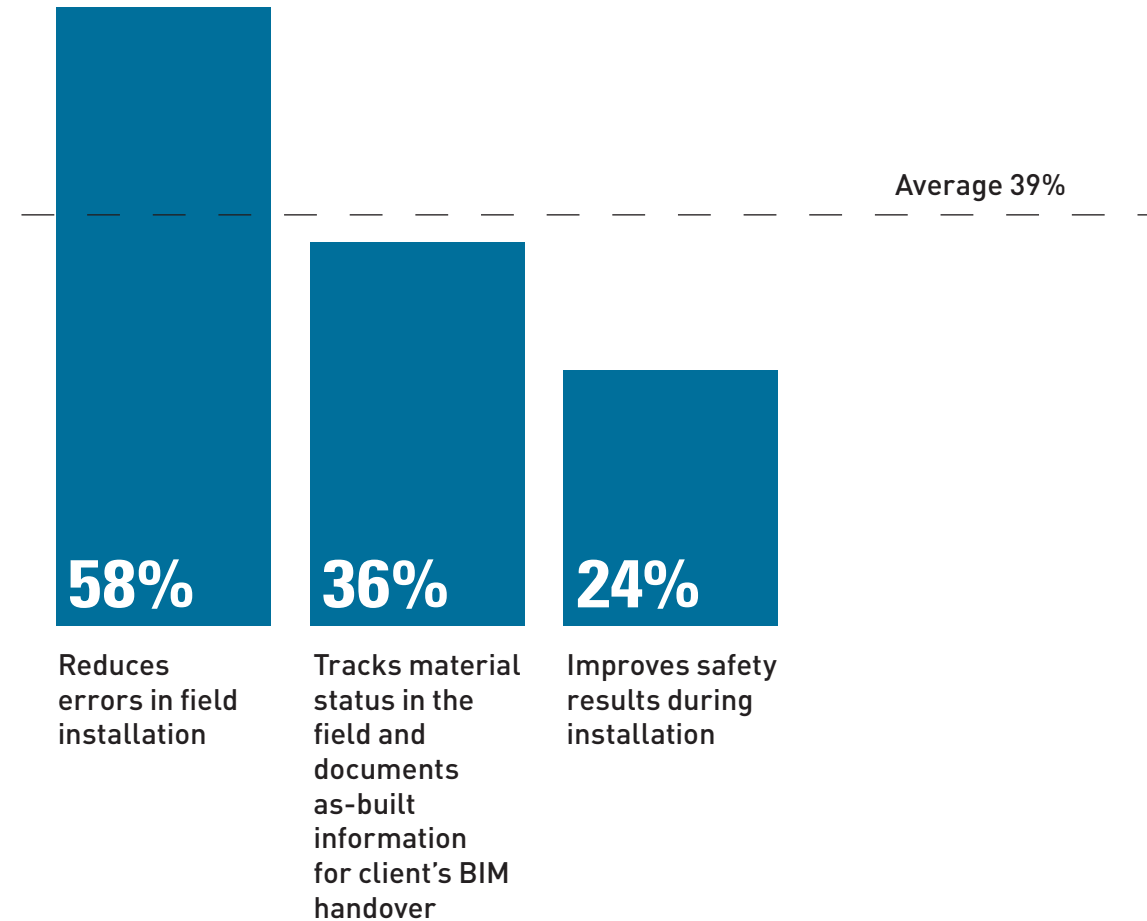

Integrated Workflow: Impact on Outcomes

IMPACT OF THE INTEGRATED WORKFLOW ON PROJECT OUTCOMES FOR STRUCTURAL AND MEP

The GC/CMs, engineers and trades rated the overall impact of the integrated workflow on three classic metrics of project performance (cost, schedule, quality), one sustainability metric (material waste) and one internal benefit (company profitability).

The percentages in the chart at right are totals of the high or very high impact ratings across all respondents. The average percentage of those ratings across all five project outcome impacts is 49%.

- Schedule (61%) and quality (59%) benefits are far higher rated than cost (39%), even by the respondents who are highly engaged with BIM (41%).
- Among company-types, MEP trades show the most enthusiasm for schedule (76%), quality (70%), reduced waste (58%) and improved profitability (58%). GC/CMs are above average for all but profitability.

BIM ENGAGEMENT INCREASES PERCEPTION OF IMPACT

While the average for reduced material waste is just 44%, encouragingly, 53% of highly engaged BIM users give it top ratings, so it definitely correlates positively with BIM experience.

Improved profitability similarly tracks to BIM experience, being cited by nearly half (47%) of high-engagement firms.

Impact on Project Outcomes

Percentage of high or very high impact ratings for five positive impacts of the integrated workflow on project outcomes

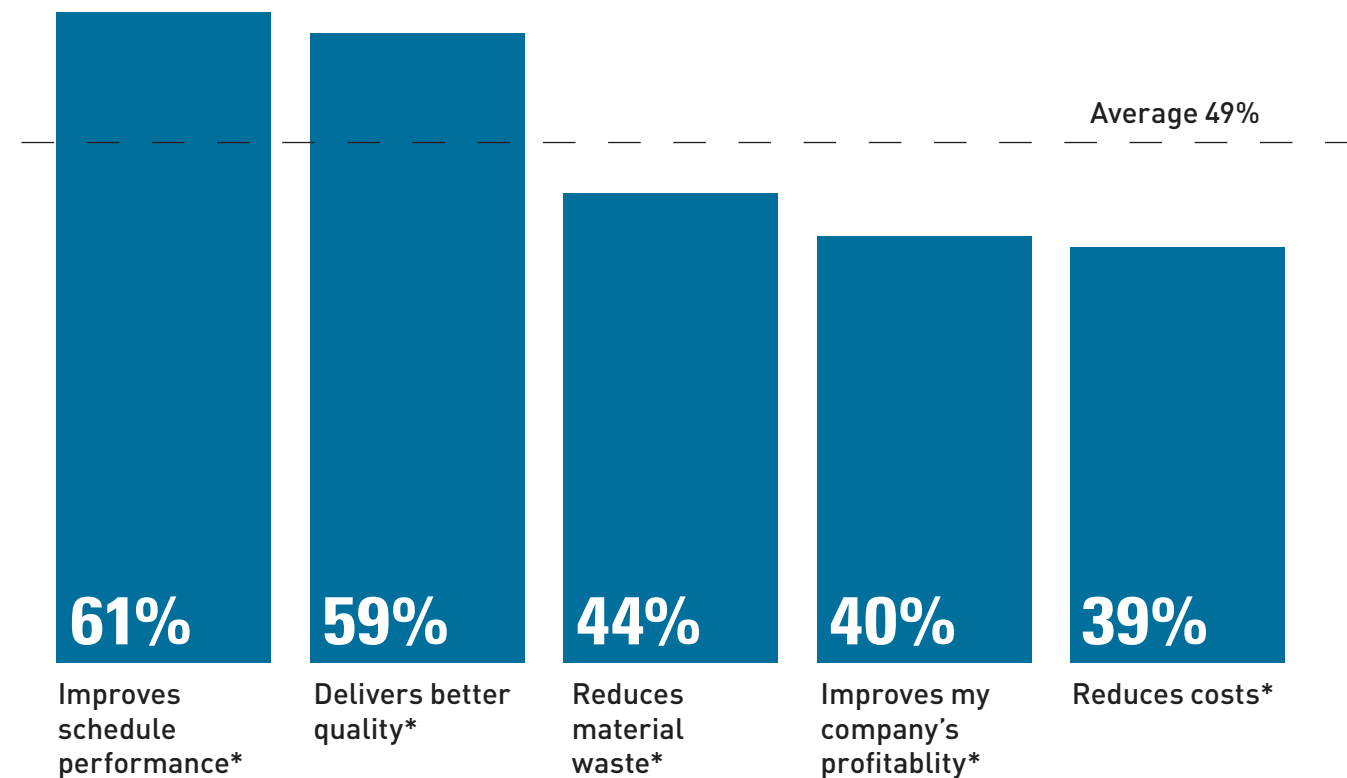

*Specifically related to the systems/aspects of the buildings addressed by the integrated workflow

Integrated Workflow: Top Current Benefits

COMPANY-TYPE PERSPECTIVES ON THE INTEGRATED WORKFLOW FOR STRUCTURAL AND MEP

This research studies a total of 15 benefits that the integrated workflow may generate for those who are engaging in it (see pages 17–19). Responses vary between the five company-types surveyed regarding how they prioritize the relative impact of each of the 15 benefits.

The matrix at right shows the top four most positively impactful benefits of the integrated workflow according to each of the five company types surveyed about it.

Top 4 Benefits of the Integrated Workflow by Company Type

Top benefits of the integrated workflow according to each of the five company-types surveyed

	Structural Engineers	MEP Engineers	GC/CMs	Structural Trades	MEP Trades
#1 Most Impactful Benefit	Enables better communication*	Enables better communication*	Enables better communication*	Enables better communication*	Reduces errors in field installation
#2 Most Impactful Benefit	Produces better coordinated designs in less time	Minimizes accurate estimates from the specialty trades	Improves schedule performance**	Produces better coordinated shop drawings in less time	Improves schedule performance**
#3 Most Impactful Benefit	Delivers better quality**	More accurate estimates from the speciality trades	Reduces duplication of tasks	Improves schedule performance**	Enables better communication*
#4 Most Impactful Benefit	Improves schedule performance**	Delivers better quality**	Produces better coordinated shop drawings in less time	Reduces errors in field installation	Produces better coordinated designs in less time

* during design, detailing, and fabrication ** related to the systems/aspects of the buildings addressed by the integrated workflow

Integrated Workflow: Most Important Future Beneficial Impacts

FUTURE BENEFITS OF THE INTEGRATED WORKFLOW FOR STRUCTURAL AND MEP

GC/CMs and the engineers and trades rated how much future impact they believe the integrated workflow will have on each of six major benefits. The percentages in the chart at right are totals of the high or very high impact ratings across all respondents.

Over half of all respondents predict high or very high future impact for five of the six benefits of the integrated workflow, indicating a strong optimism for their contributions to improving project delivery.

ROLE-SPECIFIC VARIANCES

- Structural engineers help to put better realization of design intent into the top spot with 90% rating this highly, and also help owner confidence take third place with a 76% affirmation.
- GC/CMs' above-average ratings for improved collaboration in distributed teams (89%), and attracting/retaining talent (64%), help to move them into 2nd and 4th places respectively.
- MEP trades weigh in most strongly (64%) for completing more work with less labor, aligning directly with other findings in this report about their challenges finding BIM-skilled labor (see page 4).

Predicted Future Benefits of Integrated Workflow

Percentage of respondents who predict high or very high impact in the future for each of 6 positive impacts of the integrated workflow

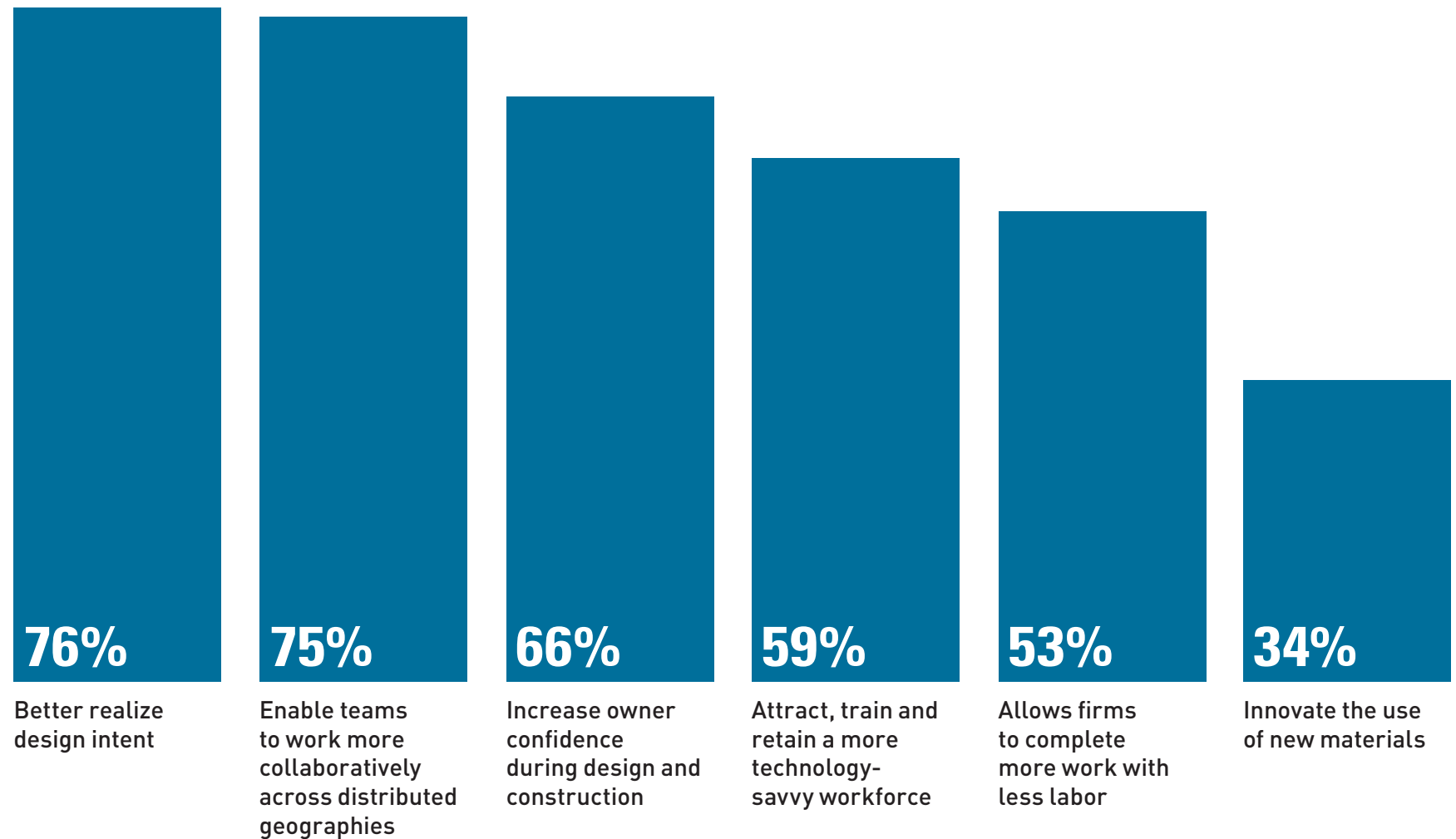

Industry Leaders

CONNECTING DESIGN AND CONSTRUCTION EXAMPLES

LEVERAGING TECHNOLOGY TO EMBRACE COMPLEXITY

The 40-story Morpheus Hotel is the fifth tower in Macau's City of Dreams complex, a premier leisure and entertainment destination. Designed by Zaha Hadid as a monolithic block encased in a striking steel and glass lattice shell, BuroHappold Engineering was retained to develop the unique exposed exoskeleton which can also be seen from inside the building, lending a delicate beauty to the vast, 40-metre high lobby and flooding it with natural light.

BuroHappold had just 12 months to complete the detailed design and documentation, within the constraints that the exoskeleton has to withstand the region's typhoon climate, and fabrication and installation would be challenged because the hotel's aluminum cladding greatly limits available locations for connections. Their team quickly decided to apply finite element (FE) analysis to determine the structural accuracy of the links needed to achieve the complex geometry. They customized software to enable processing of a huge number of models and creation of 3D visualizations of every connection for the fabricators and installers. As such, the team could focus its valuable time on the engineering solution rather than manually dealing with the data for each element.

This methodology allowed BuroHappold to deliver the project on time and at a high level of quality and coordination with the fabricators and installers.

Source: *BUROHAPPOLD*

Structural Design Integrated with Fabrication/Installation

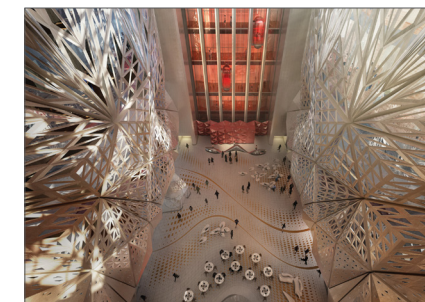

Industry Leaders: Connected Design and Construction

CONNECTING DESIGN AND CONSTRUCTION EXAMPLES

MODEL-DRIVEN DESIGN TO FABRICATION

For a large data center, The Hill Group leveraged engineering models to prefabricate major sections of air movers, a structural framework that also functioned as an external access catwalk, and 15 foot wide ductwork assemblies. Hill initially modeled feasibility, safety and pricing studies, then assembly sections and details to break work into sheet metal and structural shop orders. Finally the model was used to plan lifts and site logistics as the structural, ductwork, access and air mover sections were positioned and installed on site.

Source: HILL GROUP

DESIGN AND CONSTRUCTION TEAM COORDINATION

Coordination is critical for healthcare facilities. ENGworks provided consulting services to the mechanical contractor on an 80-bed Florida project, including mechanical and plumbing modeling, BIM coordination with the architect, engineers and other trades, and spool drawings that enabled prefabrication of racks, reducing material waste to almost zero. ENG also added Total Station points to their models allowing efficient pre-installation of hangers, sleeves and underground pipe.

Source: ENGworks

BIM-to-Fabrication/Installation Workflow

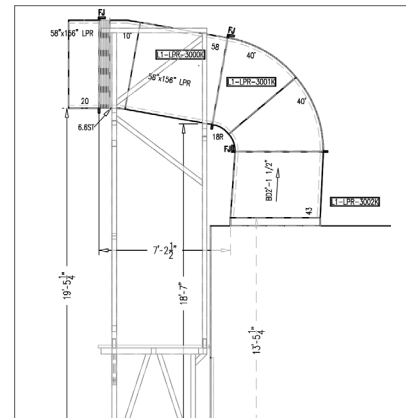

Modeled

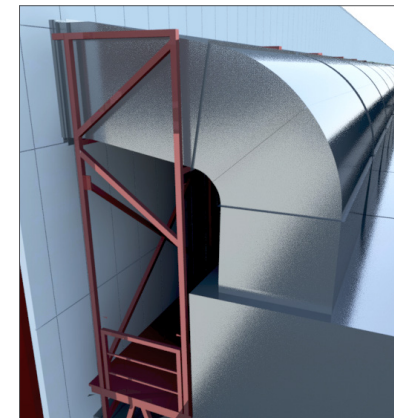

Rendered



Installed

Design and Construction Team Coordination

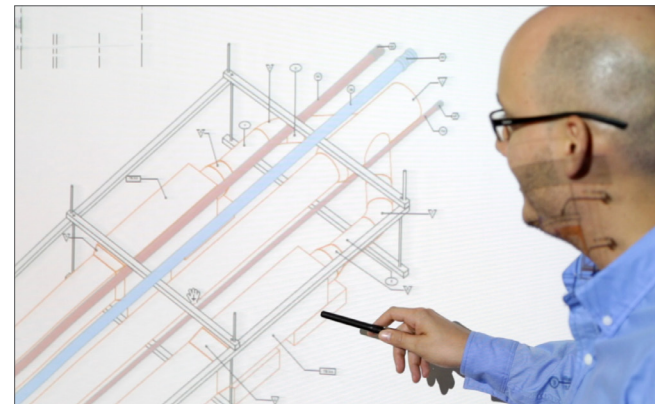

Industry Leaders: Connected Design and Construction

CONNECTING DESIGN AND CONSTRUCTION EXAMPLES

MODELING EXPEDITES COMPLEX DETAILING

A unique curved roof that mirrors a breaking wave is the signature design element for this small library in coastal California. But the steel detailing, incorporating three different rolled-steel sections with three different radiuses, had to be completed in less than a month to keep on schedule.

To meet that deadline, Colorado-based Steel Detailing Online, Inc. imported the design team's BIM into its modeling software to help generate Level 400 fabrication documents, as well as referencing the 2D contract documents provided by the contractor. This hybrid approach helped the detailer to visualize the building's complexity. "When you have a design team model, you can just rotate it and zoom into the exact spot you're looking for. You can think of a model as almost infinite pictures," says CEO Bart Rohal. BIM viewpoints also helped him work closely with the design team to greatly expedite the RFI process. "That kind of collaboration expedited the whole project," he says.

Rohal believes the BIM process and the collaborative efforts of the project team reduced the complete detailing process to five weeks from what he initially thought would be six to eight, avoiding potential liquidated damages for the general contractor.

Source: STEEL DETAILING ONLINE

Integration Achieves Design and Delivery Goals

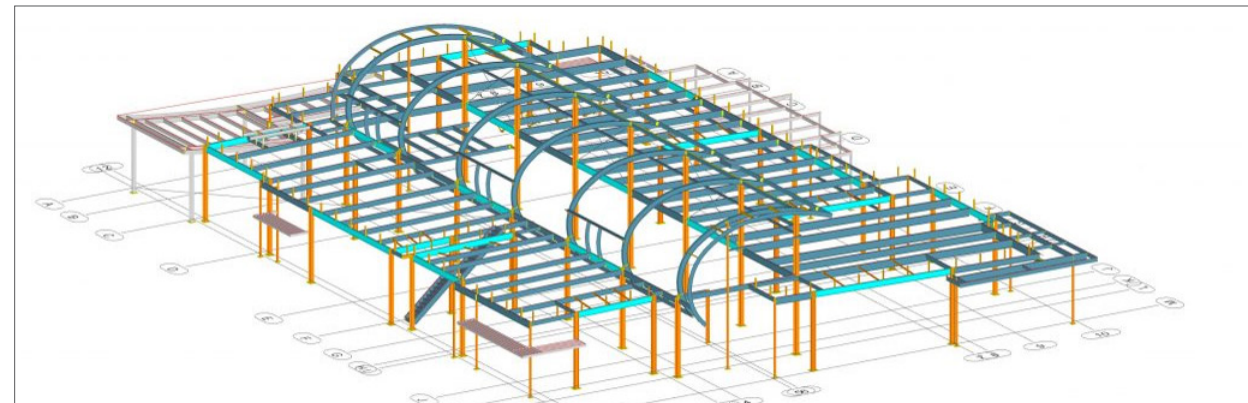

Level 400 model for steel fabrication

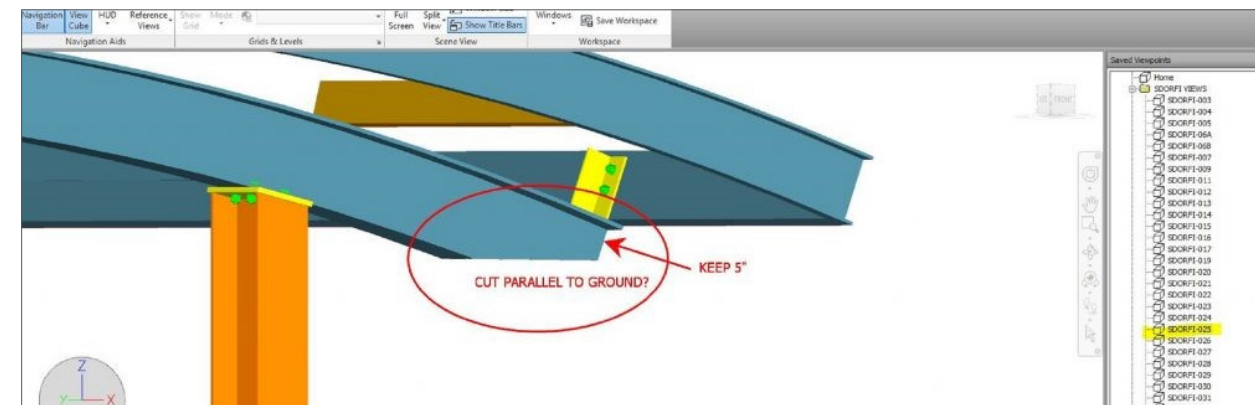

Model viewpoint used for RFI

Industry Leaders: Connected Design and Construction

CONNECTING DESIGN AND CONSTRUCTION EXAMPLES

REALITY CAPTURE TO INTEGRATE DESIGN AND CONSTRUCTION

Structural firm Ikerd Consulting was called into a challenging situation where a concrete contractor had installed anchor rods and poured the concrete for a large building on a military base, but when the steel fabricator delivered the columns, it was discovered that almost all of the rods were misplaced, thereby stopping the entire job. Compounding the problem, the client did not allow field torching of structural steel to modify the column base plates, and the fabrication facility was a six-hour drive from the site.

Ikerd Consulting CEO Will Ikerd quickly dispatched a laser scanning team to identify the angle and the location of the base of every rod at the concrete surface. “You need to know how it’s sloping,” Ikerd says. After scanning, his team used a software that extracts intelligent piping models from point cloud data and designed remedial details for every condition. Because of the accuracy of the scan, Ikerd convinced the client to allow plasma cutting so that column base plates could be efficiently adapted on site by the fabricator, allowing the job to be re-mobilized much faster than with a conventional approach.

Describing the effectiveness of this model-based solution, Ikerd says, “There is a common myth that 3D modeling takes longer than doing work in 2D, but that has all changed with laser scanning and reality capture.”

Source: IKERD CONSULTING

Laser Scanning to Develop Remedial Details in the Field

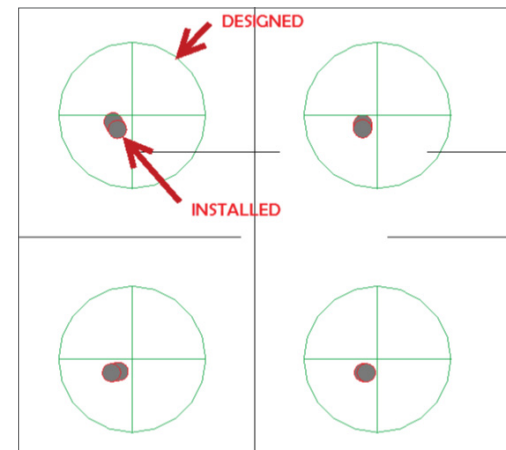

Analysis based on as-built scans

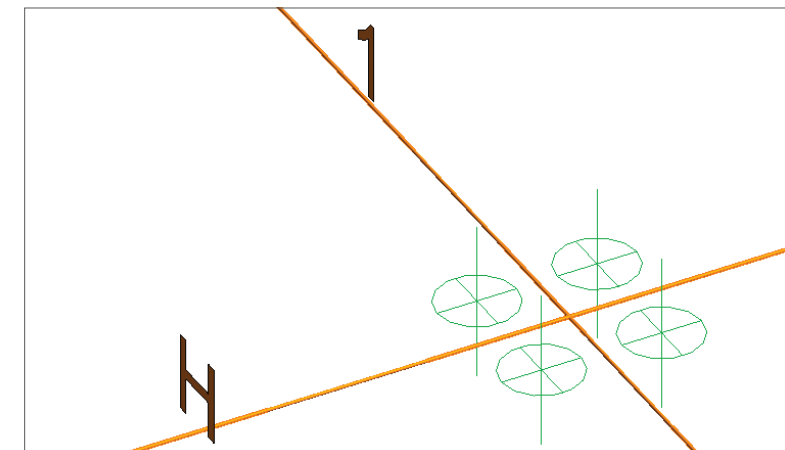

Scan imagery of misaligned rods

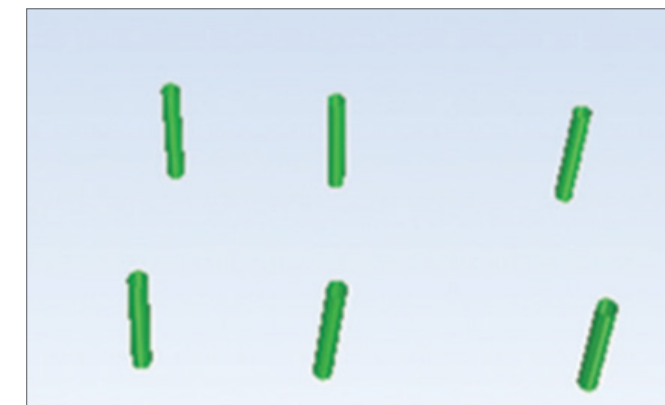

Key Takeaways

CONNECTING DESIGN AND CONSTRUCTION

FREQUENCY OF THE INTEGRATED WORKFLOW

Almost all respondents report engaging in at least some level of the integrated workflow.

- 100% of MEP trade contractors report having participated in it, with over a third (36%) saying they currently engage in a fully/nearly fully integrated workflow on more than half of their projects.
- Over 90% of the GC/CMs and structural engineers also report participating at some level.

BENEFITS OF THE INTEGRATED WORKFLOW

Over 60% of firms give top ratings to improved communication during the entire design-detailing-fabrication workflow, and faster/better coordinated designs and shop drawings. This suggests that any project team engaging in the integrated workflow can reasonably expect to achieve those benefits.

And over 58% cite fewer field installation errors as a top benefit, which has enormous implications for reducing rework and material waste, as well as improving productivity and schedule compliance.

BIM ENGAGEMENT LEVEL IMPACTS BENEFITS AND TEAM FORMATION

Significantly greater percentages of the highly engaged respondents (i.e. doing more than half their work with BIM) report receiving important benefits from their BIM use, including:

- Improved coordination
- Better cost and schedule control
- Higher quality and performance of completed building

Realizing the importance of a BIM-capable project team:

- Half of the high-engagement architects require BIM from MEP and structural engineers.
- Over 80% of high-engagement GC/CMs require BIM from MEP and structural steel trades.

CHALLENGES OF GROWTH

As BIM use and demand grows, over half of architects, engineers and trade contractors cite finding BIM-skilled personnel as a major challenge. 63% of trade contractors report using outsourced BIM services to help fill this gap.

Lack of BIM-skilled talent may influence the degree to which engineers generally lag contractors in BIM use and involvement in the integrated workflow. As BIM requirements proliferate, the industry needs to help these firms become more proficient.

EXCITING FUTURE

Respondents report high anticipation for future benefits of BIM use, including:

- Intelligent models that lead to more consistent and coordinated contract deliverables
- BIM-based processes that produce better coordinated shop deliverables in less time
- BIM as the single source of truth for project data, that is accessible anytime, anywhere in the office, shop or field

Research Demographics

SURVEY

An online survey was fielded between August and October 2016.

RESPONDENTS

Total of 210 respondents include: 52 architects; 32 structural engineers; 33 MEP engineers; 30 GC/CMs (general contractors or construction managers); 30 structural trades (detailers, fabricators, contractors); 33 MEP trades (detailers, fabricators, contractors).

All respondents:

- Do mostly buildings projects.
- Are currently involved with BIM on their projects. The chart on the upper right shows how many are highly engaged (i.e. involved with BIM on more than half of their projects).

The chart on the lower right shows the proportion of large and small firms among the respondents.

ANNUAL REVENUE TIERS

	SMALL	LARGE
Architects and Engineers	Less than \$5M	\$5M or more
Trade Contractors	Less than \$20M	\$20M or more
General Contractors Construction Managers	Less than \$100M	\$100M or more

BIM Engagement of Respondent Companies

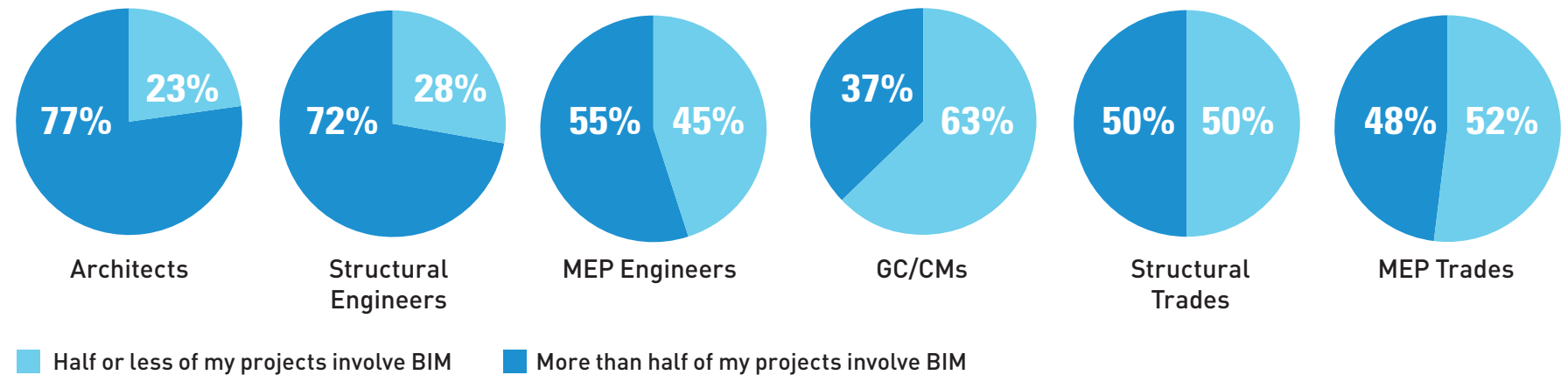

Size of Respondent Companies

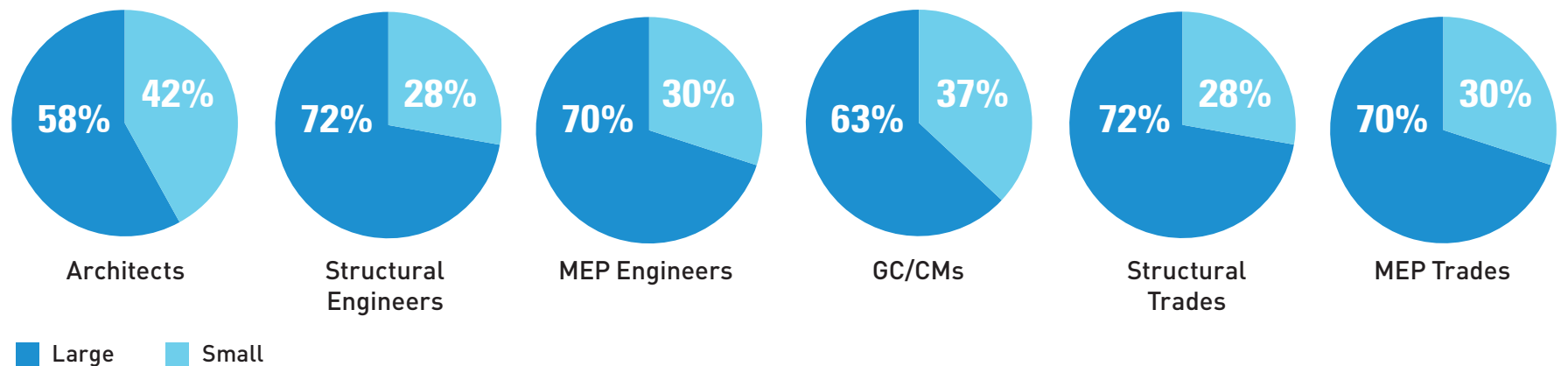

Contacts & Resources

DD&A EDITORIAL TEAM

Stephen A. Jones leads DD&A's Industry Insights Research division and is the primary author of this report. He is active in numerous industry organizations and frequently speaks at industry events around the world. Before DD&A, Jones was a vice president with Primavera Systems (now part of Oracle). Prior to that, he was principal and a Board of Directors member with Burt Hill, a major A/E firm (now Stantec). He holds a BA from Johns Hopkins and an MBA from Wharton. steve.jones@construction.com

Donna Laquidara-Carr currently provides editorial direction, analysis and content to DD&A's SmartMarket Reports. Prior to this position, she worked for nearly 20 years with DD&A's Dodge editorial team, where she gained detailed insight into the construction industry. She holds a PhD from Tulane University, an MA from Boston University and a BA from Middlebury College. donna.laquidara@construction.com



Stephen A. Jones
Senior Director
Industry Insights
Research



Donna Laquidara-Carr
PhD, LEED AP
Research Director
Industry Insights
Research



Dodge Data & Analytics: Main Website: construction.com Dodge: construction.com/dodge
Research & Analytics: www.construction.com/products/dodge-research-analytics Sweets: sweets.com
SmartMarket Reports: analyticsstore.construction.com

ADDITIONAL RESOURCES



Technology is radically disrupting the way buildings and infrastructure are designed, built and used. Disruptive innovation is transforming markets, and traditional methods of working are being displaced. Tools and processes are evolving rapidly, blurring the lines between physical and digital, and creating a new landscape for innovation and competition.

Autodesk understands the challenges our customers face today and in the future because we have a history of leading through change. Beginning 30 years ago, Autodesk led the shift from the drafting table to the computer (CAD) through the era of documentation. When 2D moved to 3D, Autodesk invested strongly, with BIM technologies that helped visualize, simulate and analyze the physical and functional performance of buildings and infrastructure before breaking ground; and now we are leading the industry's transformation to BIM during the era of optimization. Today, as new technology is disrupting the way things are designed and made, Autodesk will lead again, building upon our BIM portfolio with technology and platforms that connect designers and builders not just through the model, but through connected projects, teams, insight and outcomes that will enable a new means of creating, using, and measuring building and infrastructure systems in the era of connection.

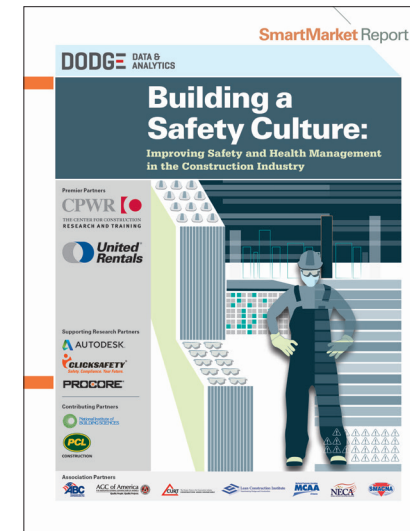
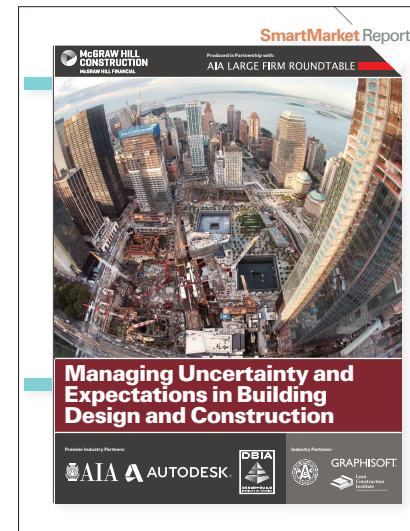
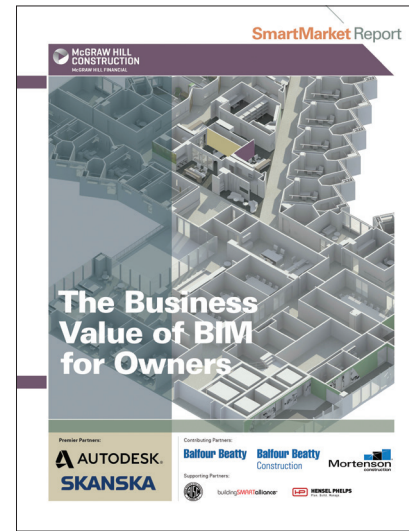

Get Smart About the Latest Trends.

About Dodge Data & Analytics Dodge Data & Analytics is North America's leading provider of analytics and software-based workflow integration solutions for the construction industry. Building product manufacturers, architects, engineers, contractors, and service providers leverage Dodge to identify and pursue unseen growth opportunities and execute on those opportunities for enhanced business performance. Whether it's on a local, regional or national level, Dodge makes the

hidden obvious, empowering its clients to better understand their markets, uncover key relationships, size growth opportunities and pursue those opportunities with success. The company's construction project information is the most comprehensive and verified in the industry. Dodge is leveraging its 100-year-old legacy of continuous innovation to help the industry meet the building challenges of the future. To learn more, visit www.construction.com.

For more information on these reports and others, visit analyticsstore.construction.com.