

Safe Harbor Statement

The presentations during this event may contain forward-looking statements about our outlook, future results and related assumptions, total addressable markets, acquisitions, products and product capabilities, and strategies. These statements reflect our best judgment based on currently known factors. Actual events or results could differ materially. Please refer to our SEC filings, including our most recent Form 10-K and Form 10-Q filings available at www.sec.gov, for important risks and other factors that may cause our actual results to differ from those in our forward-looking statements.

The forward-looking statements made in these presentations are being made as of the time and date of their live presentation. If these presentations are reviewed after the time and date of their live presentation, even if subsequently made available by us, on our website or otherwise, these presentations may not contain current or accurate information. We disclaim any obligation to update or revise any forward-looking statements.

Statements regarding planned or future development efforts for our products and services are not intended to be a promise or guarantee of future availability of products, services, or features but merely reflect our current plans and based on factors currently known to us. Purchasing decisions should not be made based upon reliance on these statements.

All Autodesk content is proprietary. Please Do Not Copy, Post or Distribute without authorization.

Daniel Liu **Rivian**
Crafted Quality Engineer

Jeff Higgins **Autodesk**
Senior Solutions Engineer

Dan Lincoln **Autodesk**
Technology Consultant

Digital DVAC

Visualizing Parts, Realistically



About Daniel

Taiwan → Illinois → California

Mechanical Engineer

University of Illinois Urbana-Champaign '24
FSAE, Robotics, Human-centered Design

Rivian Career

Manufacturing, 2023
Perceived Quality, 2024
Full time Perceived Quality, 2025



About Jeff



Pennsylvania → Kentucky → Michigan

Mechanical/Plastics Engineering Tech
Penn State University – The Behrend College

Background

Plan A Development - Trinity Industries
Process Engineer – Adam Mfg.
Senior Solutions Engineer - Moldflow



What Is Perceived Quality?



Craftsmanship



Voice of the Customer



Making a
product that
capture the
5 senses



Enhancing & Defining the Brand



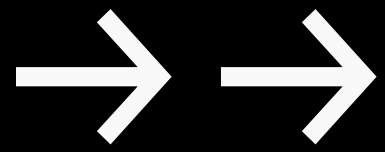

Turning the
subjective into
engineering
objectives



What is
DVAC?





What is
DVAC?

Design
Validation
Appearance
Certificate





What is
DVAC?

Design
Validation
Appearance
Certificate

Also known as AAR
(Appearance Approval Report)

Approve part appearances for
production use



Downsides & Limitations of DVAC



Time Consuming Process

Every customer-facing part

Pre-texture & Post-texture assessments

Fixing defects after-the-fact

Unavoidable but costly process!

Time consuming as well

Tooling change, supplier loops, etc.



How do we predict defects and fix them before production?



Digital DVAC

New Technology for Virtual Review

Review parts during design
process with photo-realistic
visualizations

Allows us to catch defects
before tooling kickoff

Sets expectations & improves
part approval rates
→ Reduces Cost
→ Reduces Development time



Digital DVAC Examples

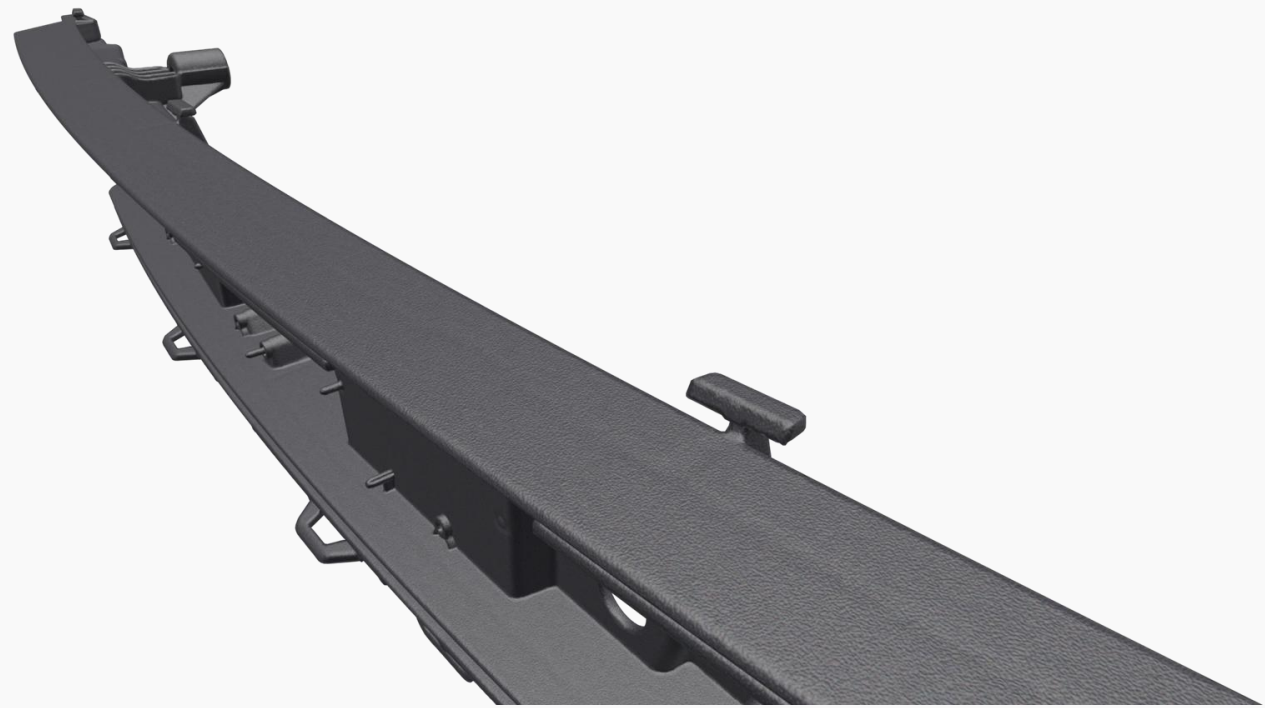

Digital DVAC Examples



Digital DVAC Examples



What causes this?

Definition: Indentations on the surface of a plastic part typically found opposite a feature on the opposing side

- Trade-offs
- Appearance
 - Rigidity
 - Mass/Cost

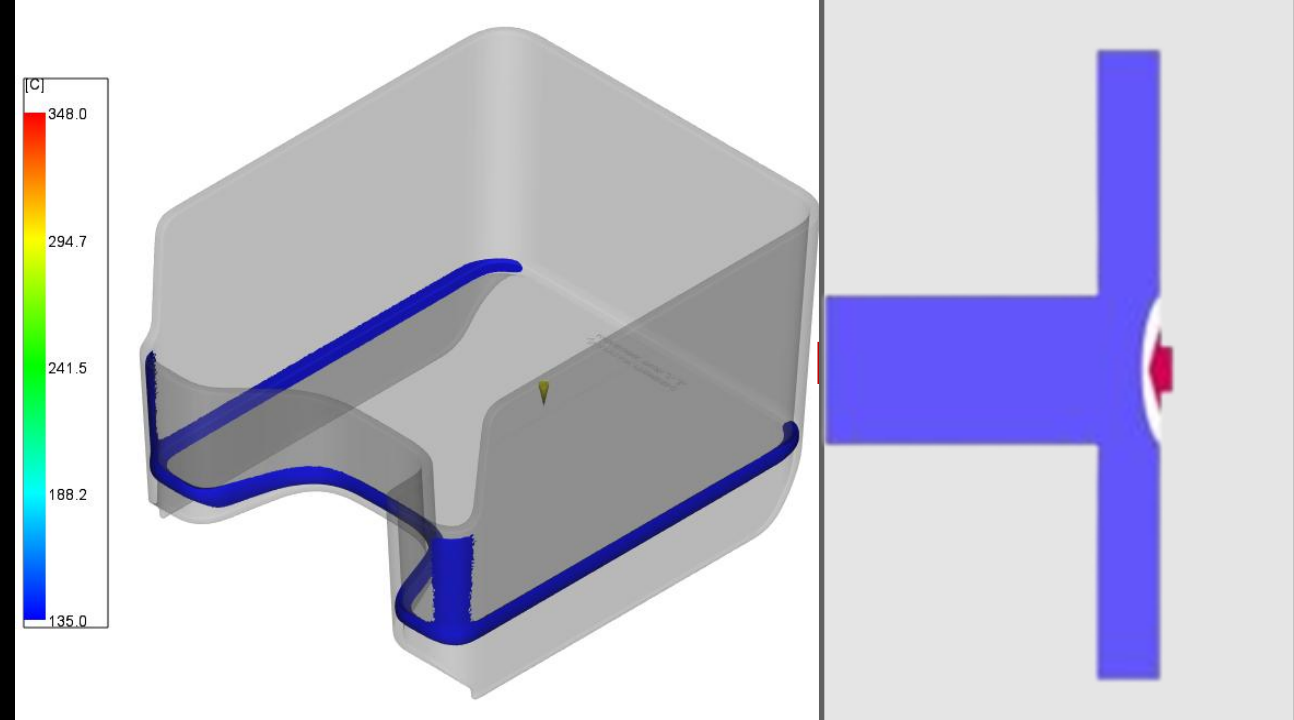

Workflow 1

Direct Moldflow Method |
Moldflow VRED

Run Moldflow
simulations with a fine
mesh that can directly
be exported into VRED



12+ Million Mesh Elements

Pros

Most straightforward

Cons

Time consuming to generate fine mesh
Time consuming to run simulation
→ Suppliers aren't willing to run these studies



Moldflow Analysis

Real world measurement: 0.08mm
The finer the mesh, the finer the result

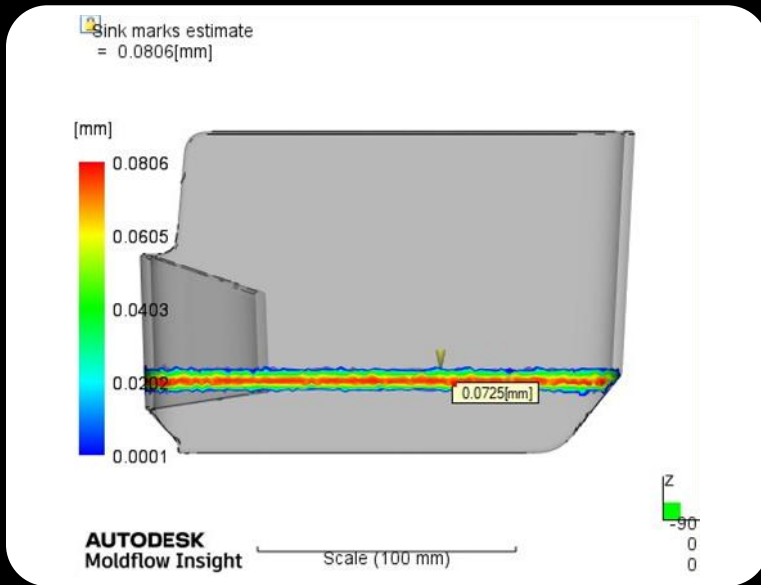

1.5M Elements
Sink = 0.0725 mm

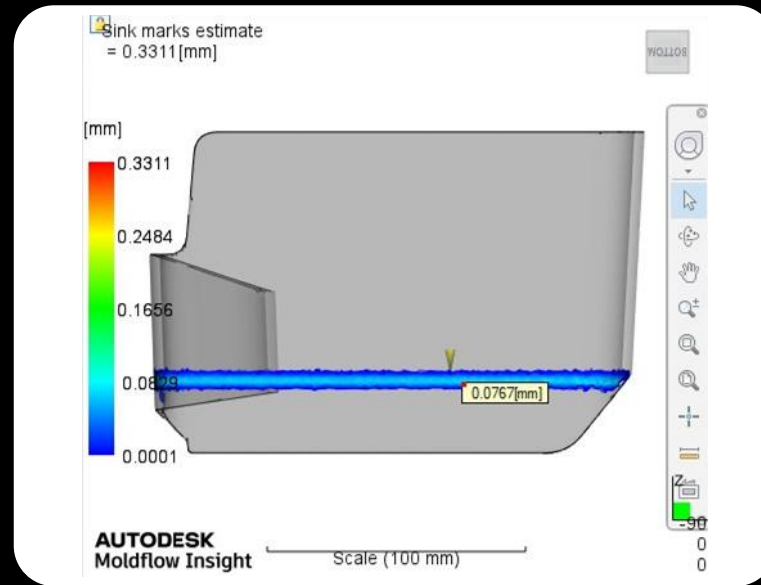

3.2M Elements
Sink = 0.0767 mm

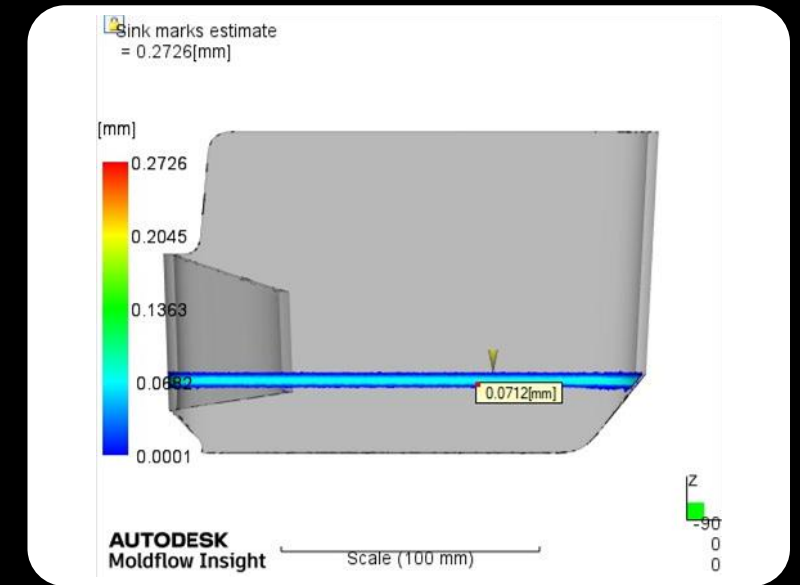

12.8M Elements
Sink = 0.0712 mm



VRED Visualization

The limitations of this method



That's **not** what an accurate sink mark looks like

The fine-mesh Moldflow study took
24+ hours!



If the supplier is
already running
Moldflow, why re-
run it?



Workflow Option 2

Defect Mapping Method



Moldflow

Leverage production level
Moldflow studies being run by
engineering & suppliers

Fusion

Take defect heat maps and map
onto solid model in Fusion using
Texture Extrude feature,
generating deformed bodies

VRED

Take deformed mesh into VRED
for visualization, applying texture
and color to match real world
expectations



Workflow Option 2

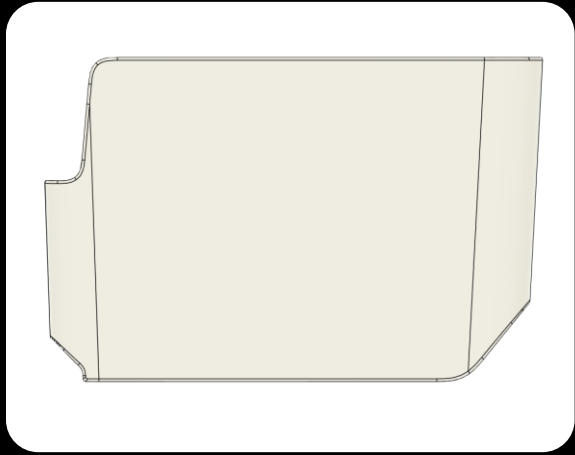

CAD

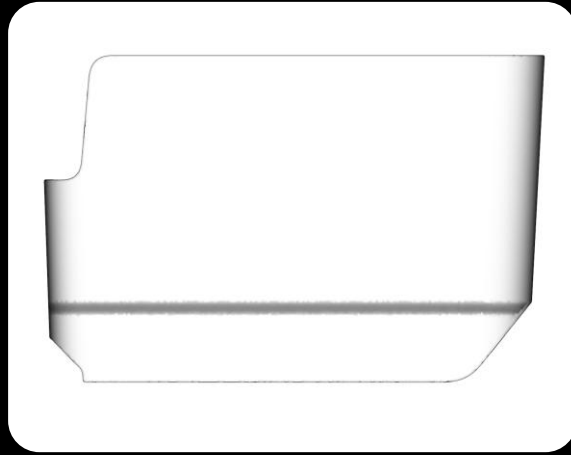

Moldflow

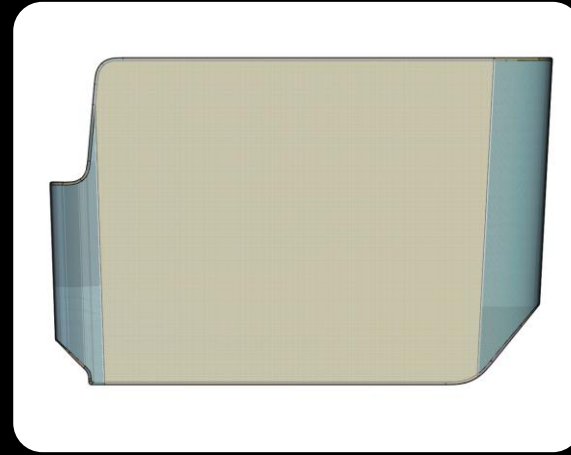

Fusion



VRED



Process Demonstration

Process in Action

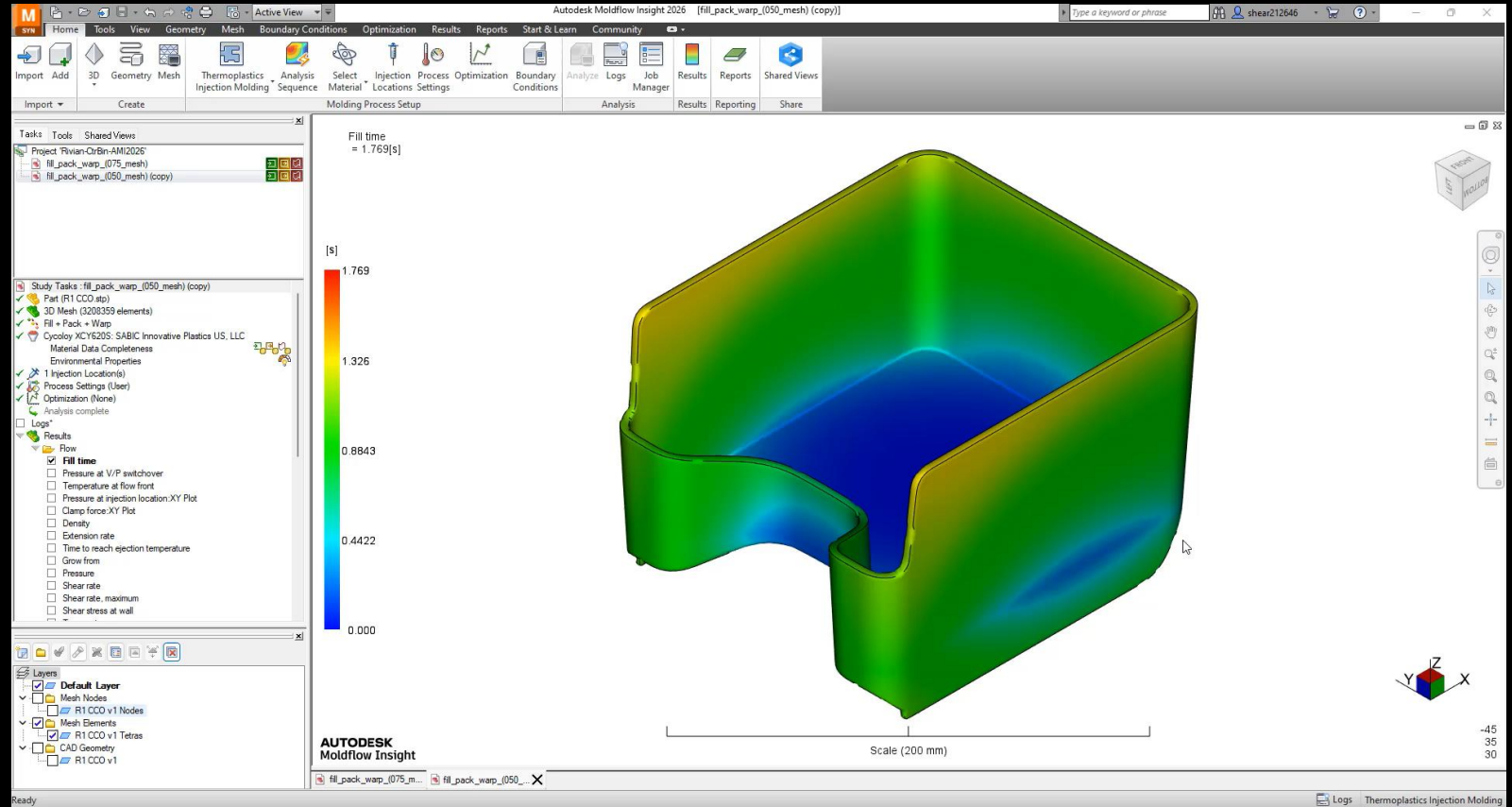

VRED Visualizations Studio Review

Sample different
textures to hide defects

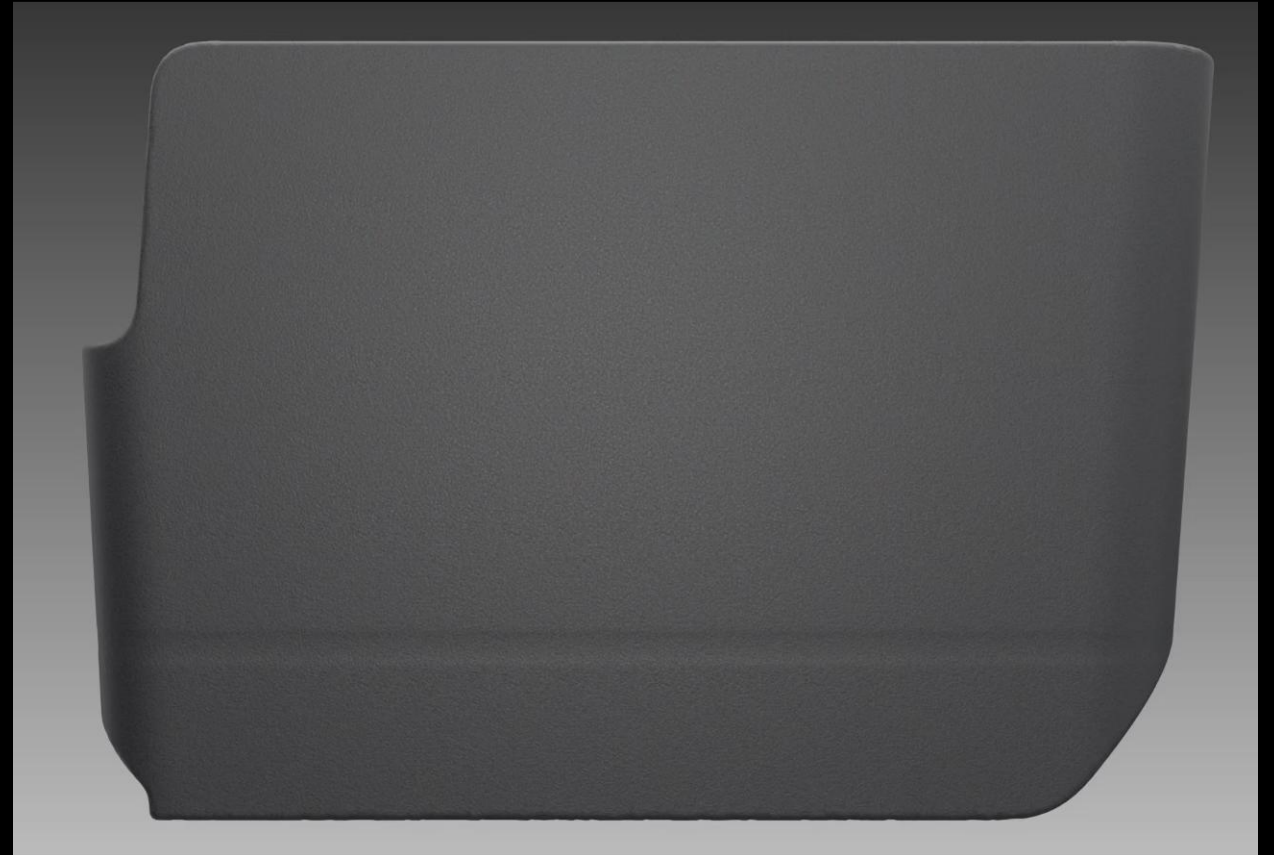

Process Recap Pros & Cons

Direct Moldflow Method

- +** Most accurate, full body result
- Have to re-run Moldflow studies
- Moldflow mesh isn't designed for visualization

Defect Mapping Method

- +** Can export from any Moldflow study
- More manual mapping work
- Fusion meshing & export limitations



Potential Next Steps

Ideas Worth Exploring

Could a fully deformed body (FBX) be exported directly out of Moldflow?

Could a fully unwrapped sink-heat map be exported?



Potential Next Steps

More Thoughts

Texture Extrude

- Function Enhancements
- Autosizing Images

Meshing

- Alternative Formats (Quads)
- Surface Deformation



The Impact Benefits of Digital DVAC



The Impact Benefits of Digital DVAC

A white Rivian SUV is parked on a cobblestone street. The car has a blue stripe along the side and the word 'RIVIAN' on the front fender. The background shows a city skyline with several tall buildings under a clear sky.

Integrate into Ok-to-tool process

→ Catch issues before ever cutting steel

Improve DVAC Efficiency

→ Set realistic expectations, from virtual to physical





AU 2025

THE DESIGN & MAKE CONFERENCE

Autodesk and the Autodesk logo are registered trademarks or trademarks of Autodesk, Inc., and/or its subsidiaries and/or affiliates in the USA and/or other countries. All other brand names, product names, or trademarks belong to their respective holders. Autodesk reserves the right to alter product and services offerings, and specifications and pricing at any time without notice, and is not responsible for typographical or graphical errors that may appear in this document.

© 2025 Autodesk. All rights reserved.