

Moldflow 2027

What's new

Hanno van Raalte, Product Manager for Moldflow



Agenda

Moldflow 2027

Moldflow Scandium 2027 Update

Final Thoughts



Moldflow 2027



Moldflow 2027 | Release overview

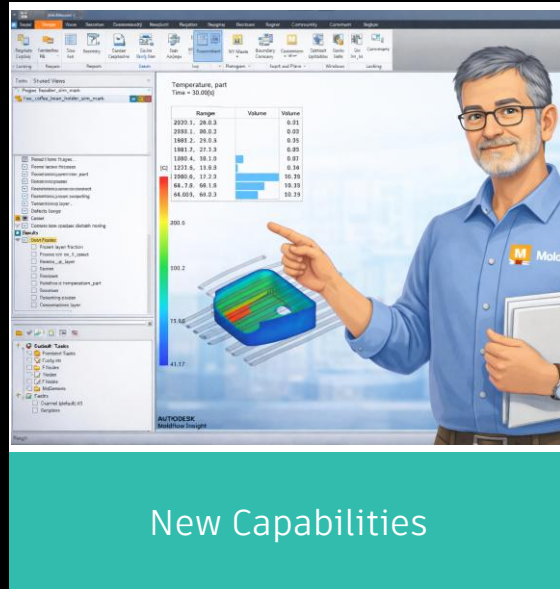

New Capabilities

- Graphics performance improvements
- Export Moldflow results in VTK format
- Autodesk Assistant powered AI
- Cooling Optimization if for Drill and Plug molds

Tech Preview (Scandium)

- New cooling Solver (Cool FAME)
- Mixed valve gate triggers for MP/DD and 3D
- 2 shot and Insert over molding improvement

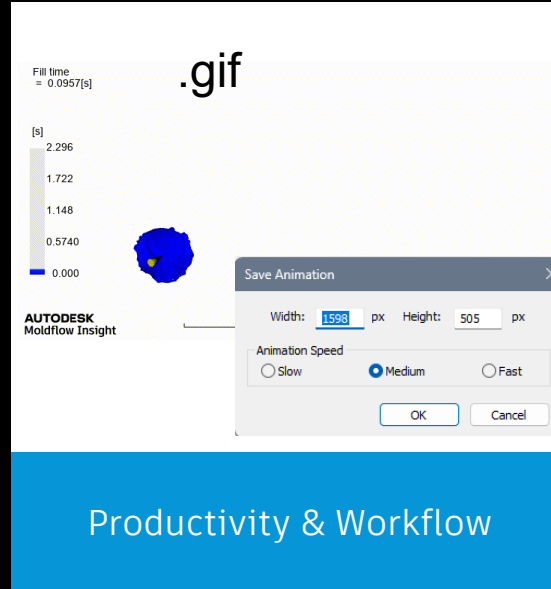

Productivity & Workflow

- API Improvements:
 - New and Improved Command window to support the Python API.
 - New StudyRlt and API options
 - AiAssistant utility extracts summary data
- Animation Export improvements:
 - .gif file is available again
 - New options
- Component updates:
 - CAD translator updates
 - Material database update

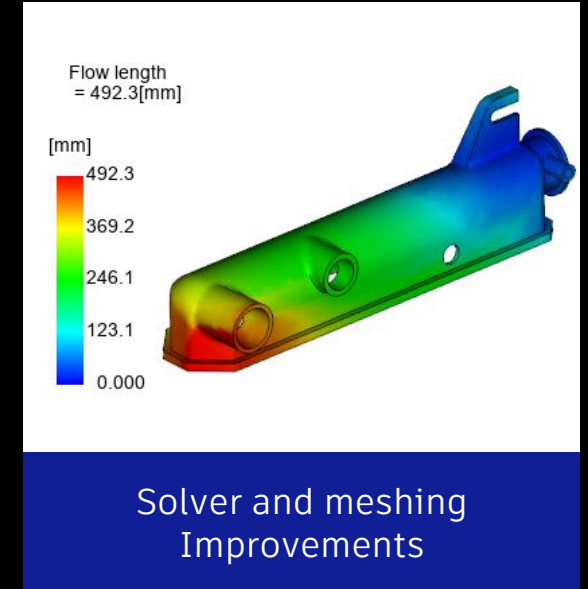

Solver and meshing Improvements

- Accuracy improvements:
 - 3D corner effects (off by default)
 - Improved residual Stress calculation for Midplane and Dual Domain.
- 3D mesh refinement around the gate
- New Flow length result for 3D
- Hershell-Buckly cross WLF viscosity model for thermoplastic (MP/DD/3D)
- Various solver improvements:
 - Influence of outer heater temp. on hot runner temperature
 - “Time to reach ejection temperature” improvement for 3D
 - Cavity weight result

Moldflow 2027 | Graphics Performance Improvement

- Moldflow 2026's graphics pipeline is upgraded and will give you a higher refresh rate when working with large models.

2026

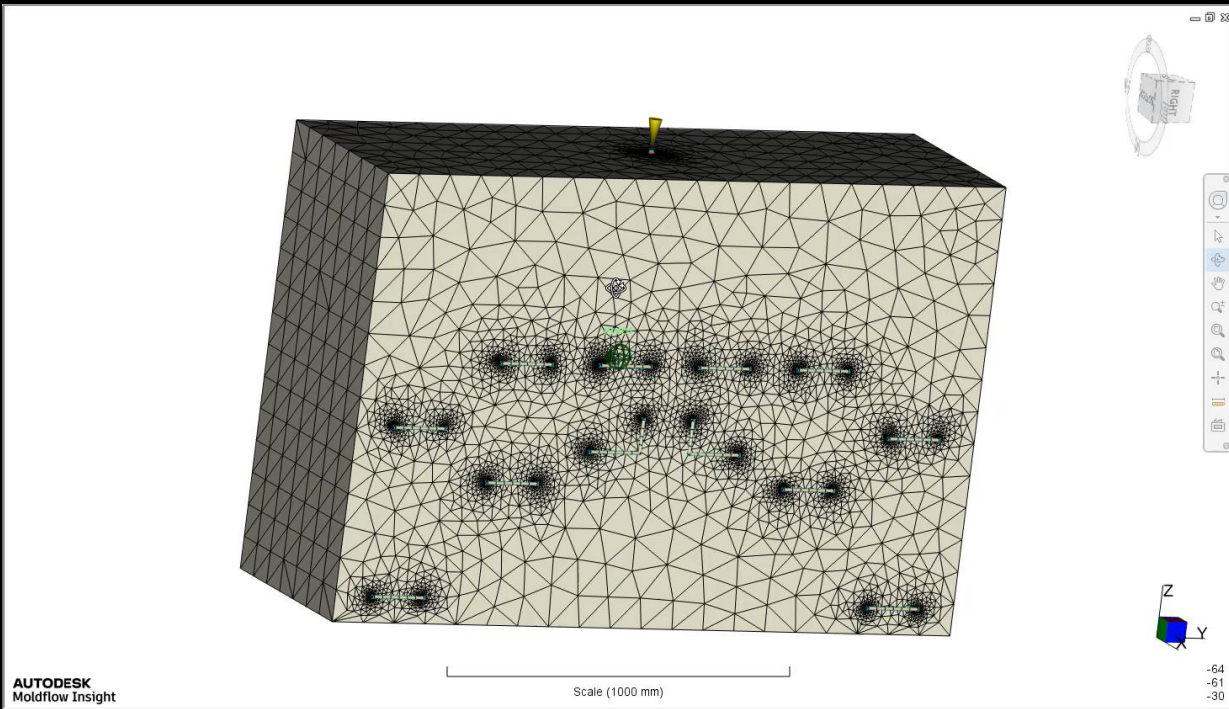

2027

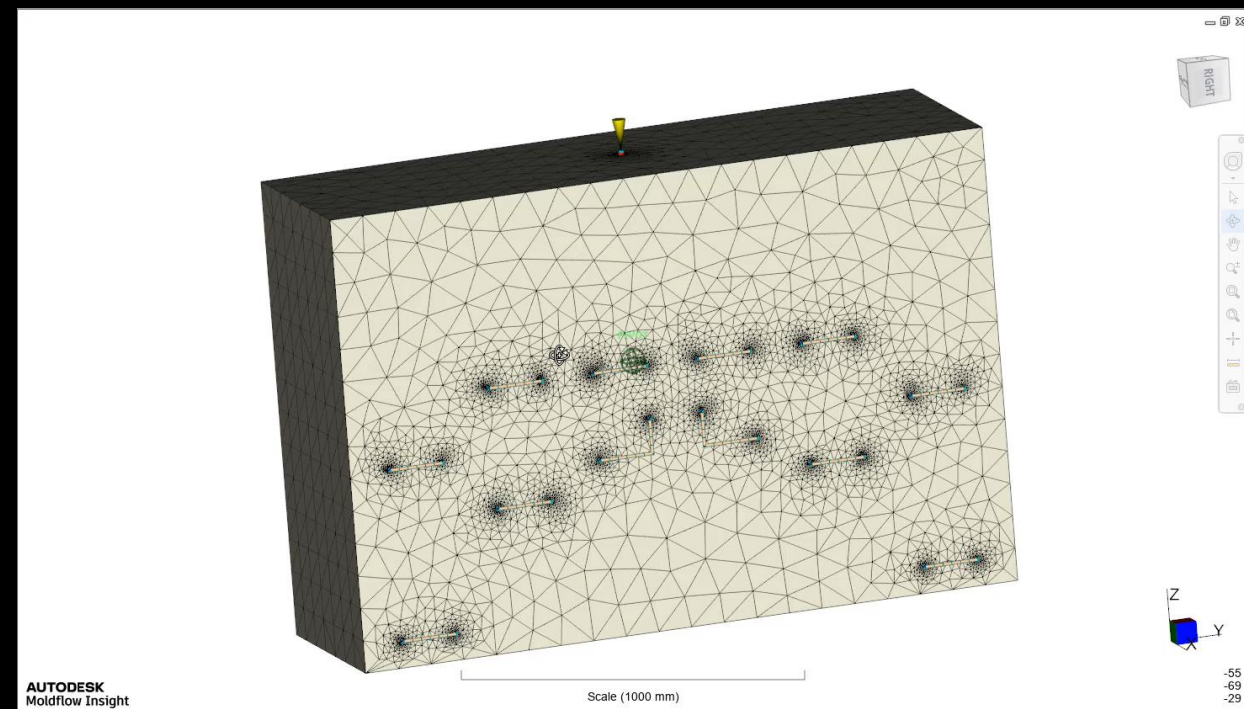

Moldflow 2027 | Graphics Performance Improvement

- Moldflow 2026's graphics pipeline is upgraded and will give you a higher refresh rate when working with large models.

2026

2027

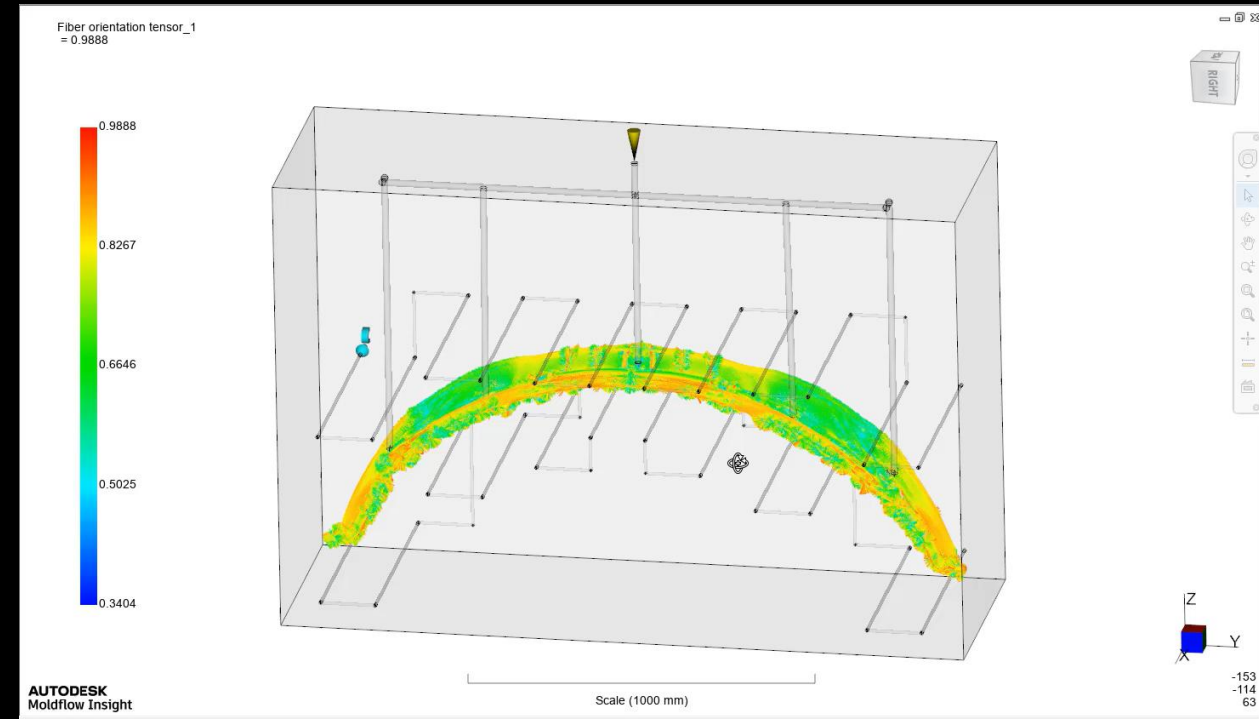
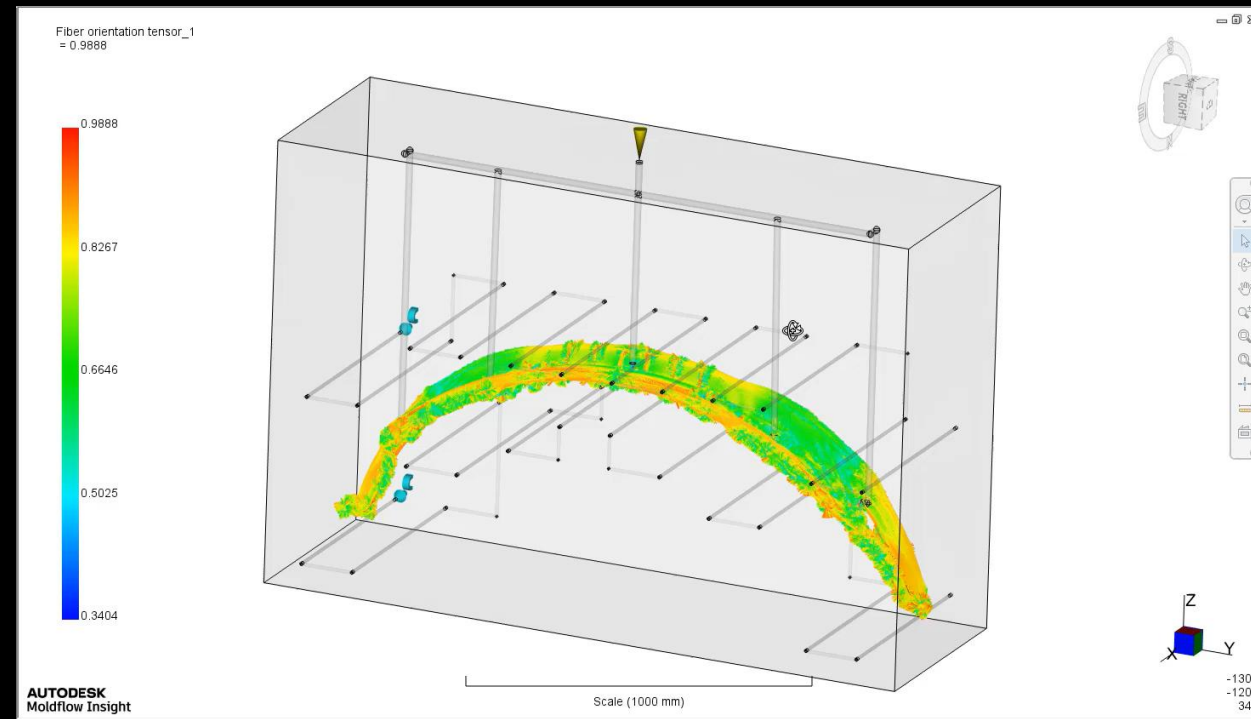

Moldflow 2027 | Graphics Performance Improvement

- Moldflow 2027 can now tap into GPU for graphics taps into modern GPU.
- Nvidia Control Panel workflow

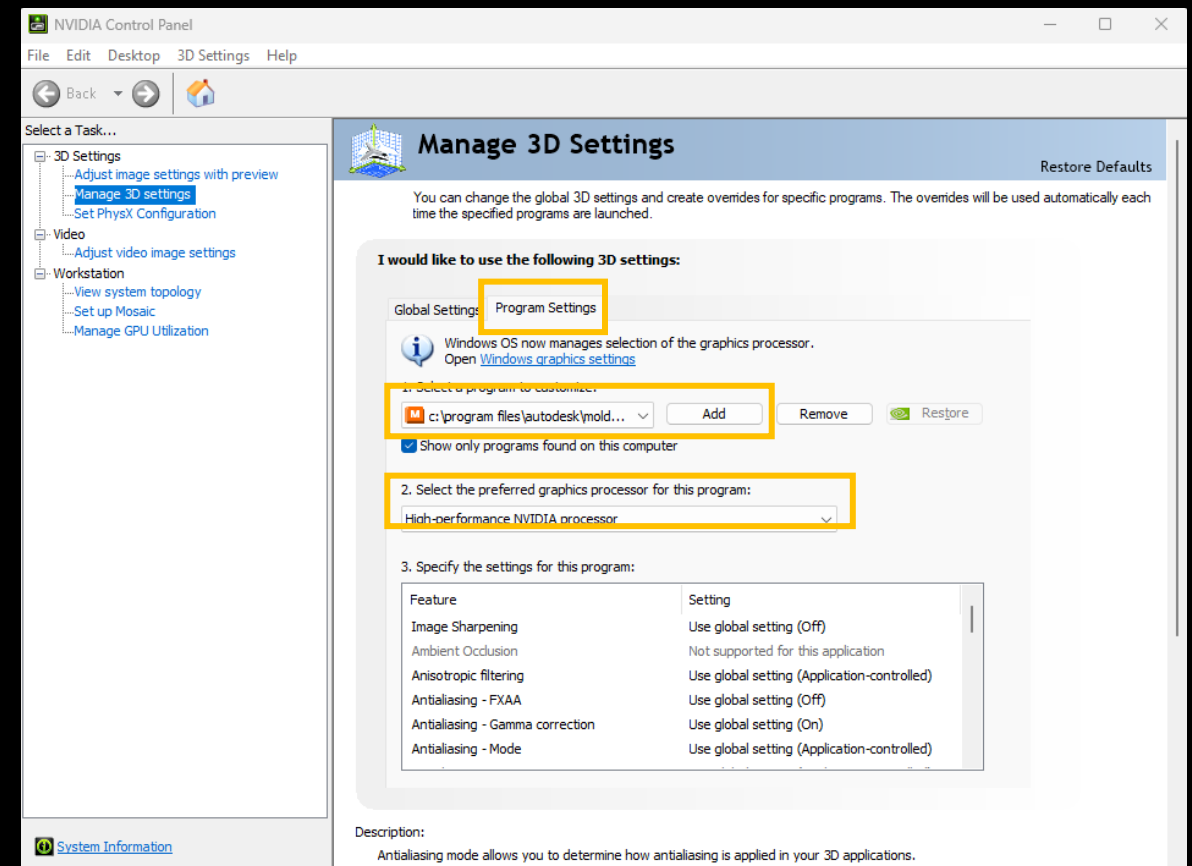
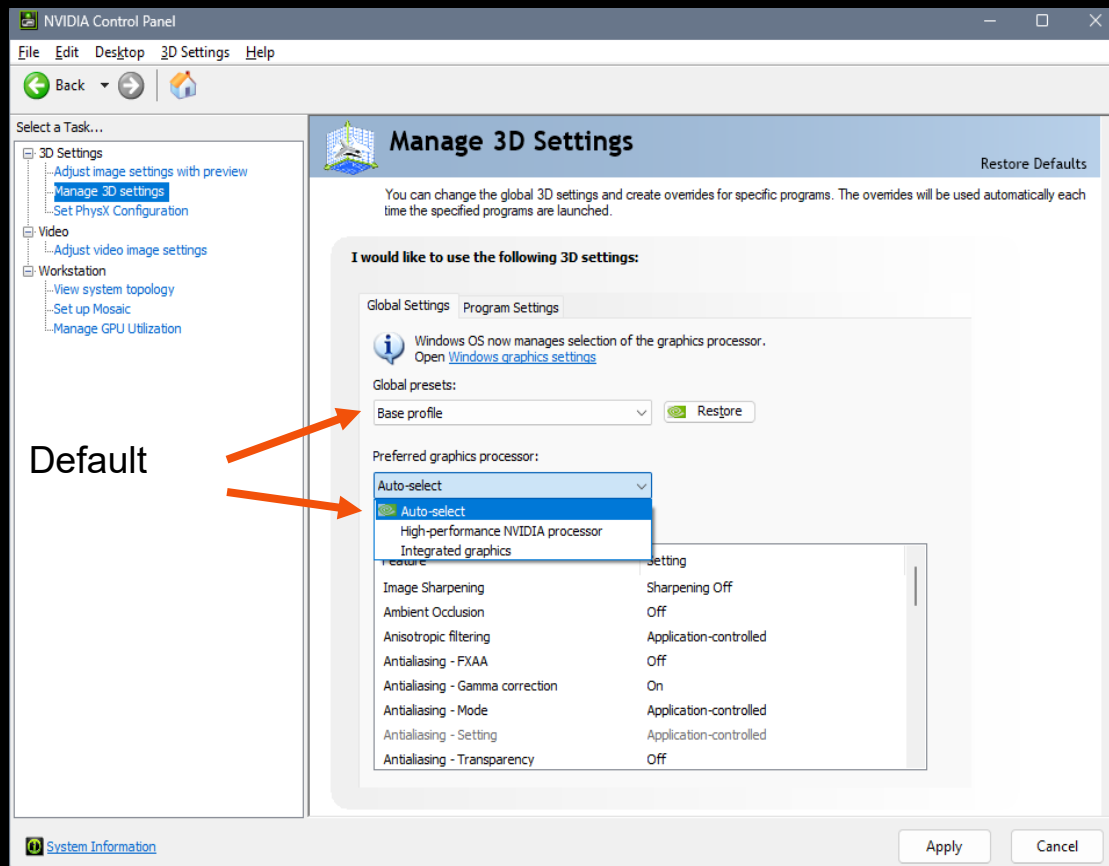

Moldflow 2027 | Graphis Performance Improvement

- Windows 11 workflow. Right click on Desktop > Display Settings

The image shows a Windows 11 workflow for adding a desktop application to the performance settings. It consists of three overlapping windows:

- Custom settings for applications:** A settings window with a search bar and a filter dropdown set to "All apps". Two buttons are visible: "Add desktop app" (highlighted with a red box) and "Add Microsoft Store app".
- File Explorer:** A window showing the path `OS (C:) > Program Files > Autodesk > Moldflow Synergy 2027 > bin`. A table of files is displayed with columns for Name, Date modified, Type, and Size. The file `synergy.exe` is selected.
- Application Performance Settings:** A window showing the settings for the application `airsyn_synergy.exe`. The "GPU preference" is set to "High Performance (NVIDIA RTX A1000 6GB Laptop GPU)". There is also a toggle for "Optimizations for windowed games" which is turned on, and a "Reset" button.

Name	Date modified	Type	Size
mlc.exe	3/10/2026 3:43 PM	Application	1,184 KB
mpi2str.exe	3/10/2026 3:43 PM	Application	10,113 KB
network-licensing-configuration.exe	3/10/2026 3:43 PM	Application	302 KB
sdytocad.exe	3/10/2026 3:43 PM	Application	732 KB
senddmp.exe	3/10/2026 3:43 PM	Application	2,626 KB
studymod.exe	3/10/2026 3:43 PM	Application	2,550 KB
studyrft.exe	3/10/2026 3:43 PM	Application	10,210 KB
synergy.exe	3/10/2026 3:43 PM	Application	36,000 KB
synergycleanreg.exe	3/10/2026 3:43 PM	Application	28,000 KB
synmesh.exe	3/10/2026 3:43 PM	Application	10,000 KB
tess2cad.exe	3/10/2026 3:43 PM	Application	5,000 KB

Moldflow 2027 | Graphis Performance Improvement

- Now taps into GPU efficiently

2026

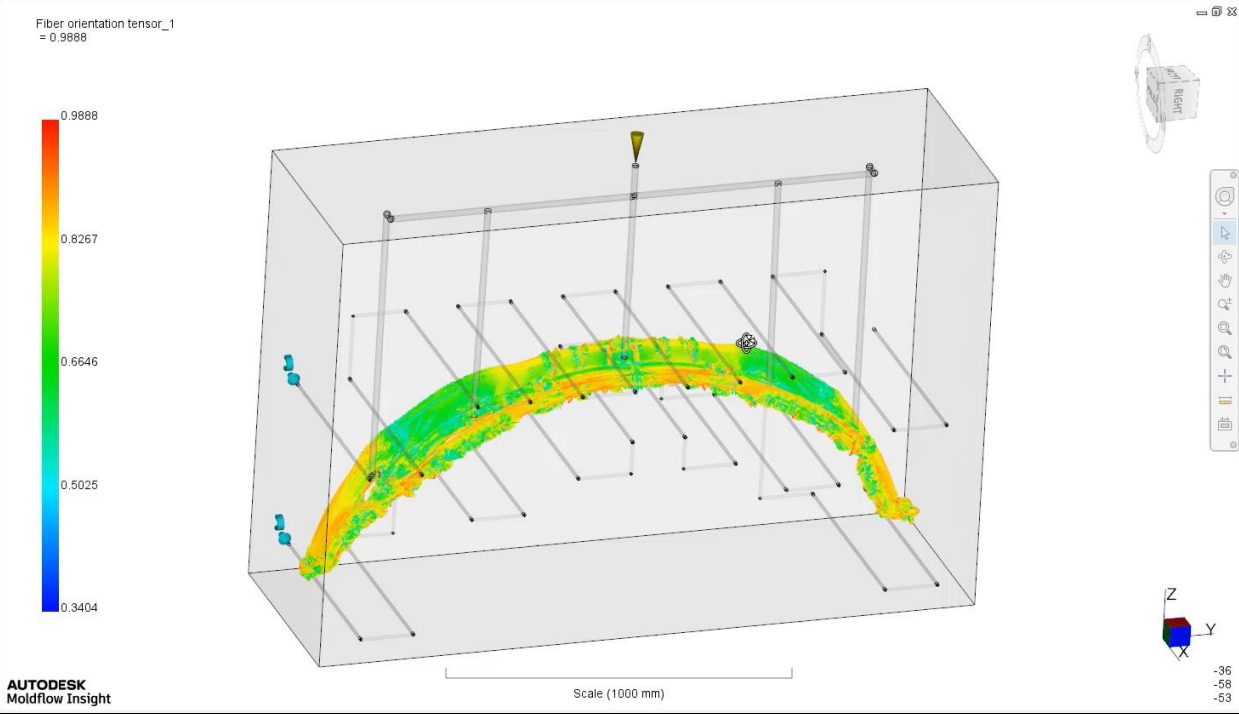

2027

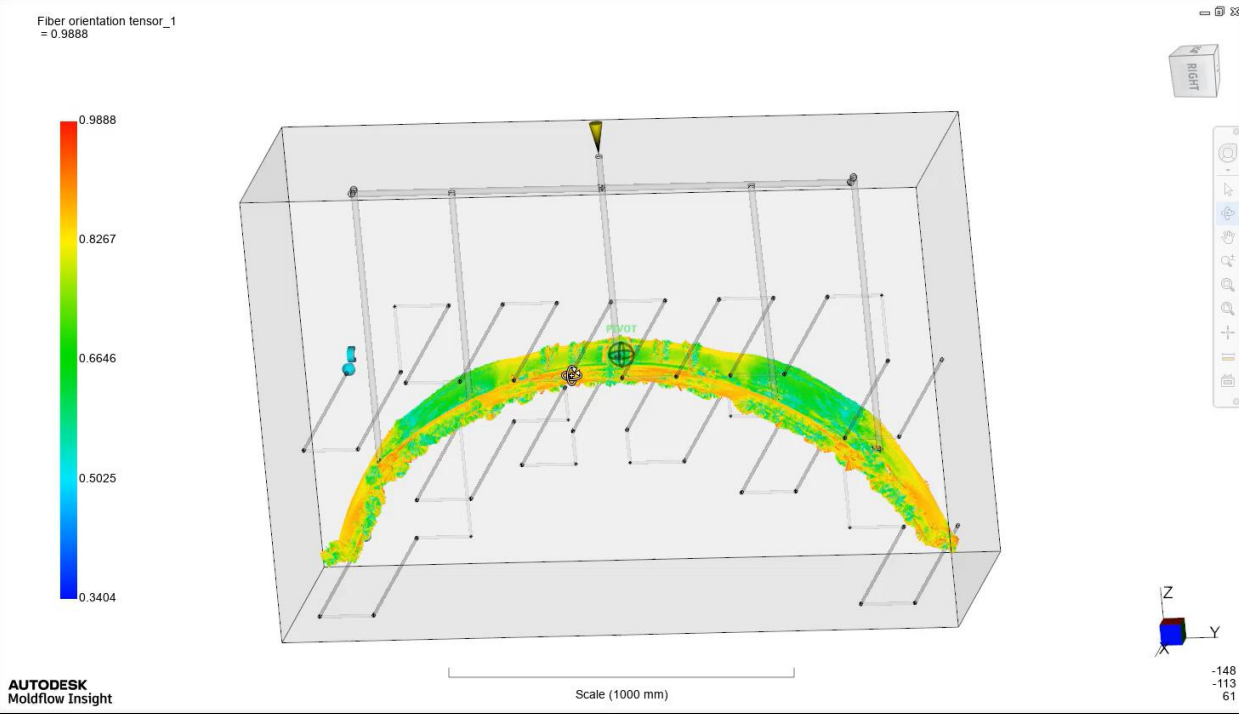

Moldflow 2027 | Graphis Performance Improvement

- This major development fixes a lot of long-standing graphics issues:
 - 'box' around the legend is gone.

Before

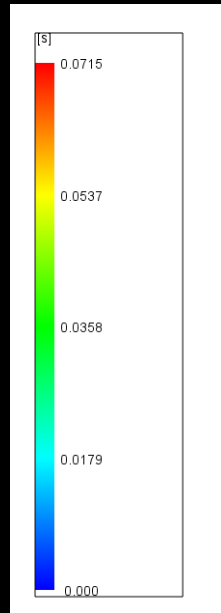

2027

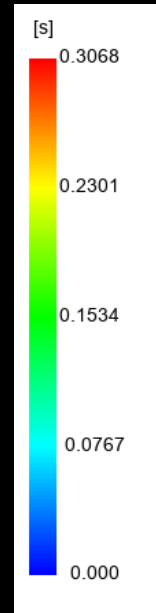

Moldflow 2027 | Graphics Performance Improvement

- This major development fixes a lot of long-standing graphics issues:
 - 'box' around the legend is gone.
 - Split/multi-study results display problem.

Before

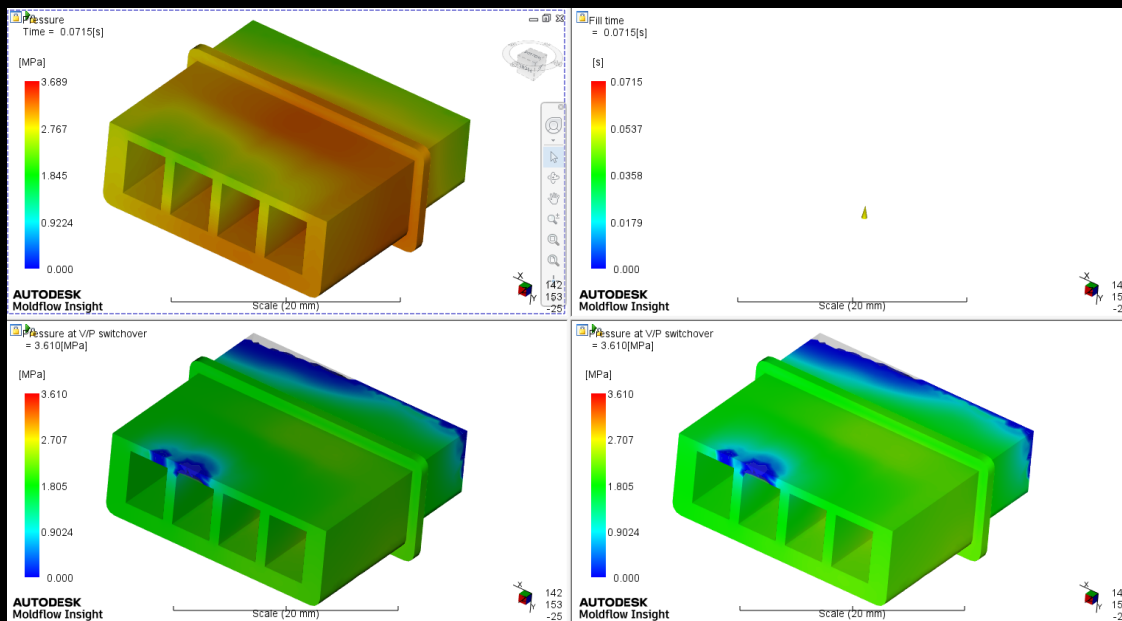

2027

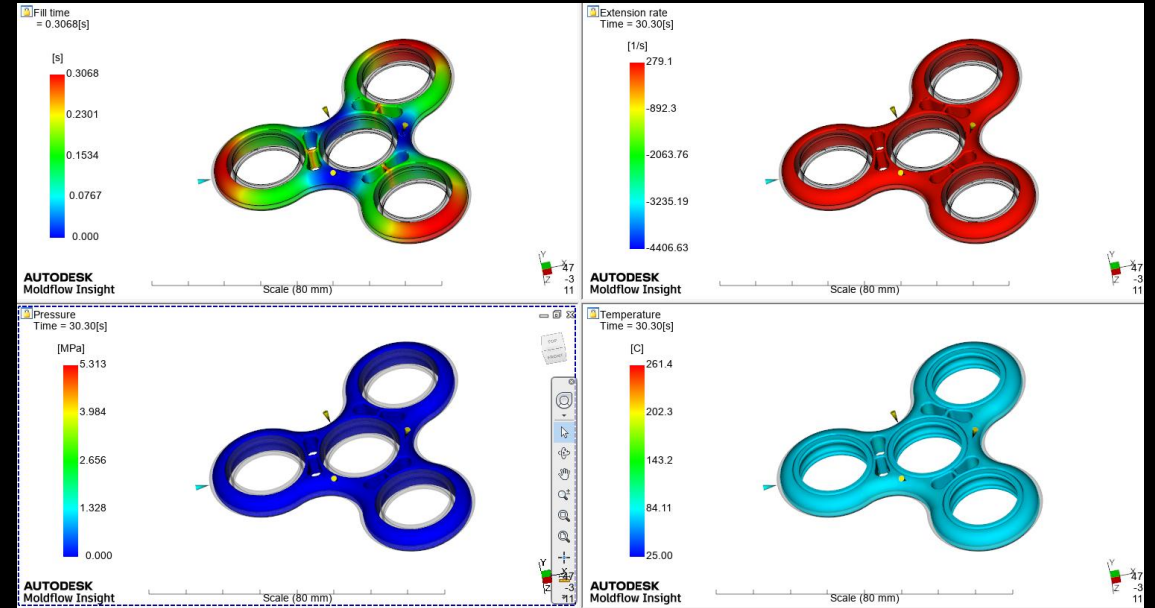

Moldflow 2027 | Graphics Performance Improvement

- This major development fixes a lot of long-standing graphics issues:
 - 'box' around the legend is gone.
 - Split/multi-study results display problem.
 - Path line termination selection.

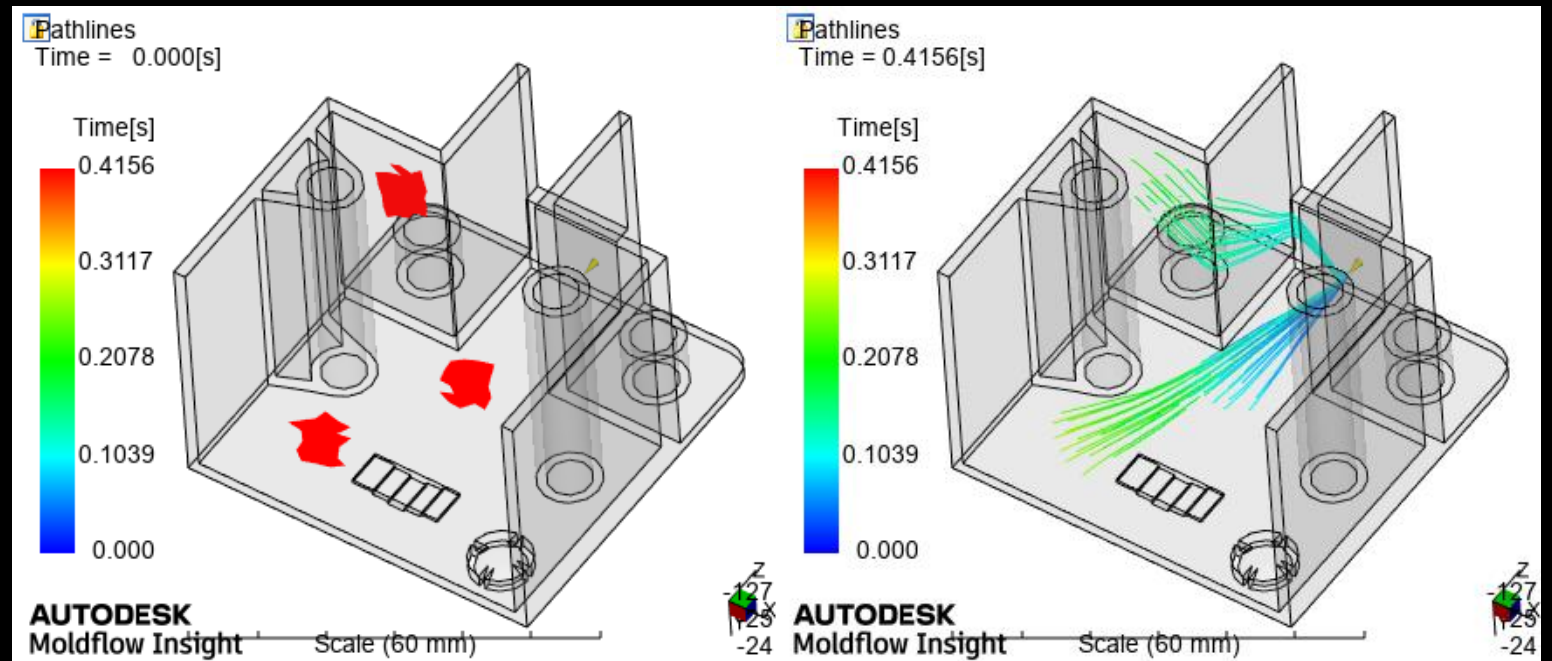

Moldflow 2027 | Graphis Performance Improvement

- This major development fixes a lot of long-standing graphics issues:
 - 'box' around the legend is gone.
 - Split/multi-study results display problem.
 - Path line termination selection.
 - New 'drag' examine

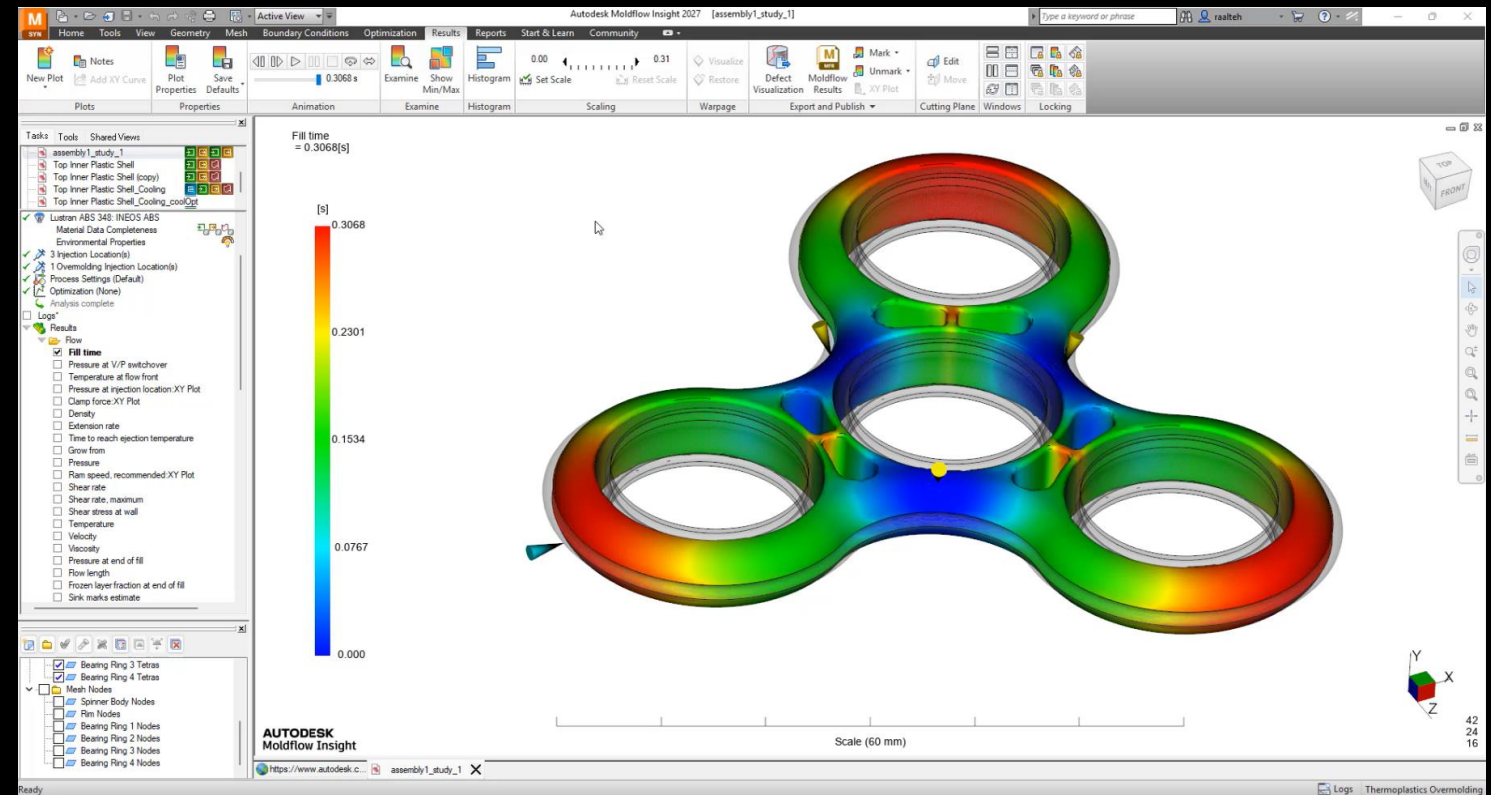

Moldflow 2027 | Graphis Performance Improvement

Tools > Rotate Performance Tool

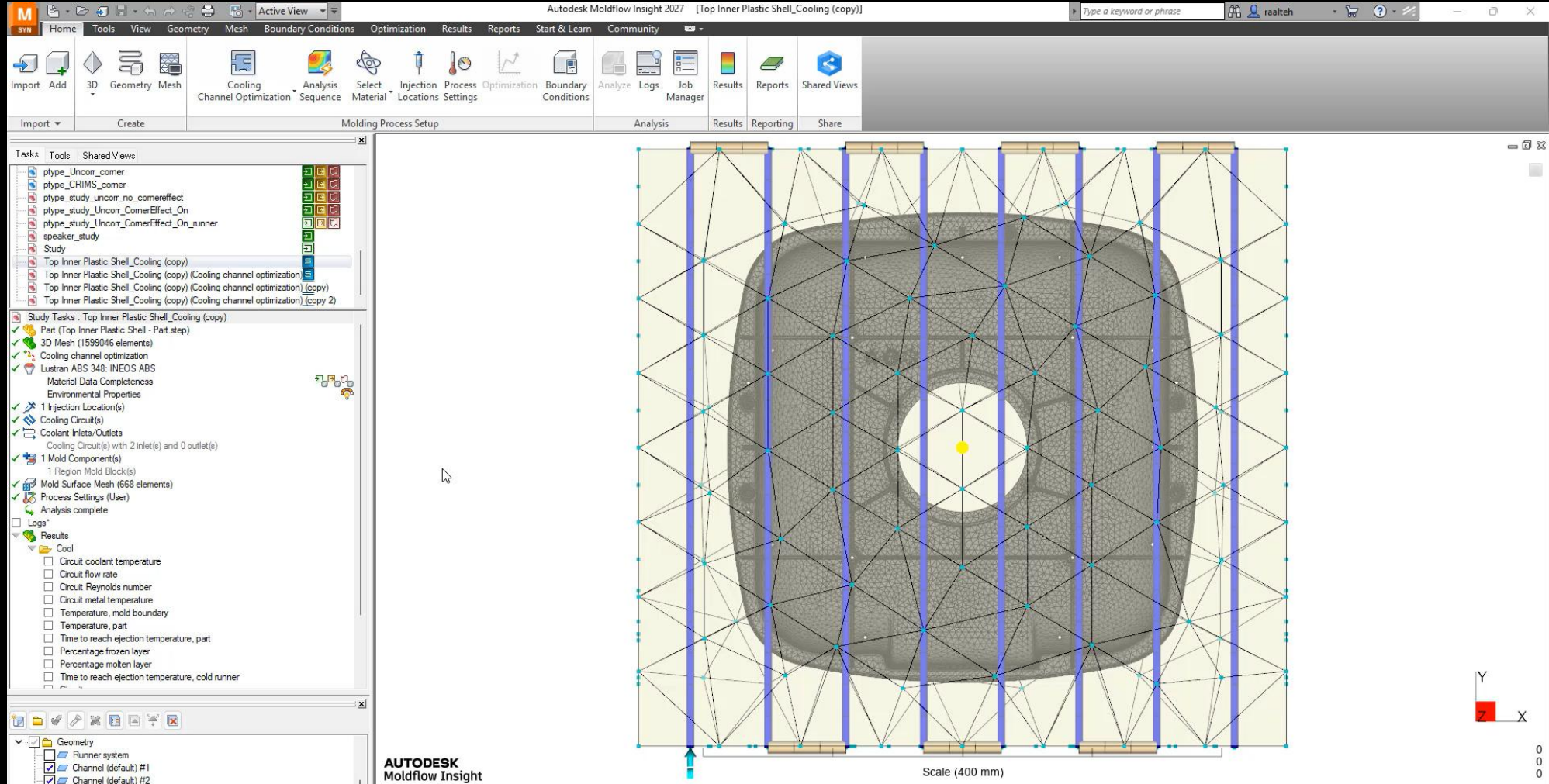

Moldflow 2027 | Export results in VTK format

- VTK is then a widely used open-source visualization tool kit and is used in Moldflow Synergy to view data.
- Results exported in VTK format can be used to be used in 3rd party viewers like ParaView and other applications.

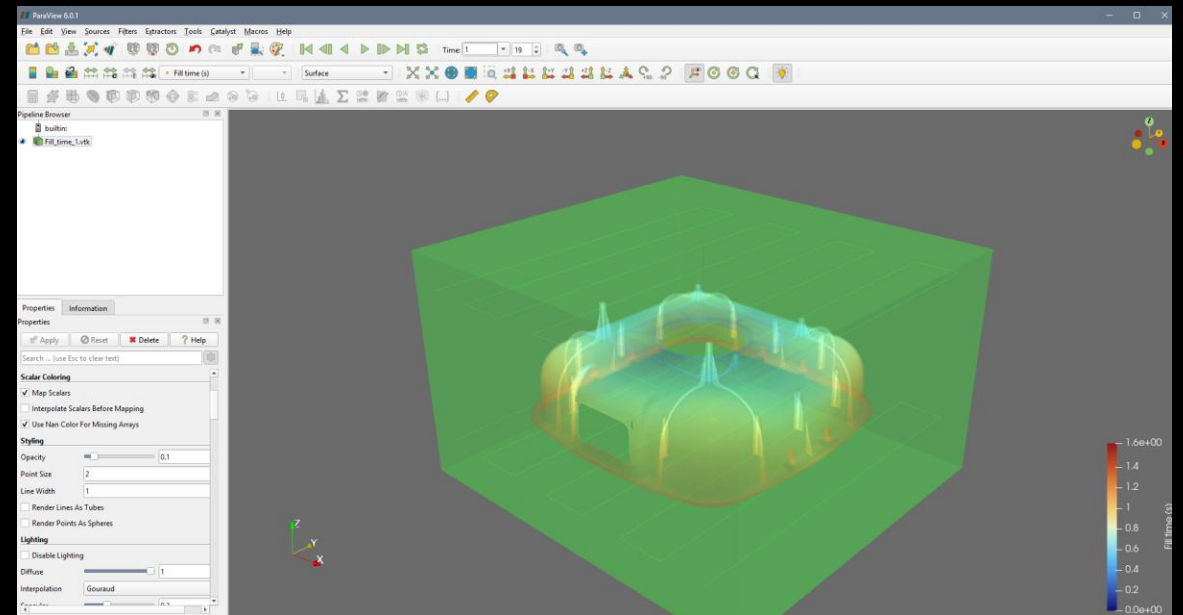
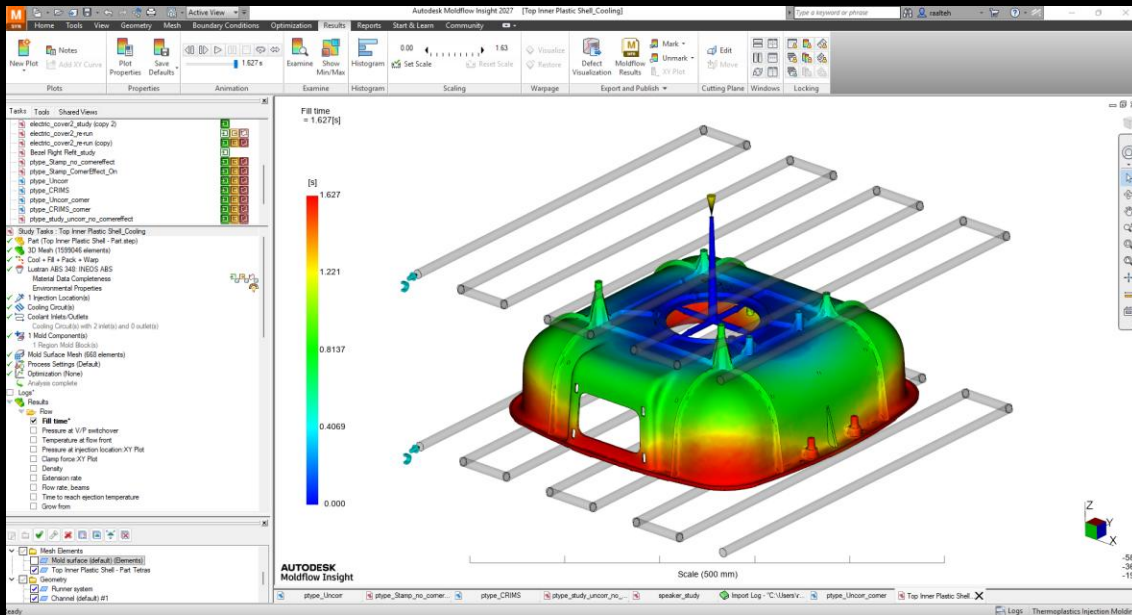

Moldflow 2027 | Cooling Optimization if for Drill and Plug molds

Starting Point

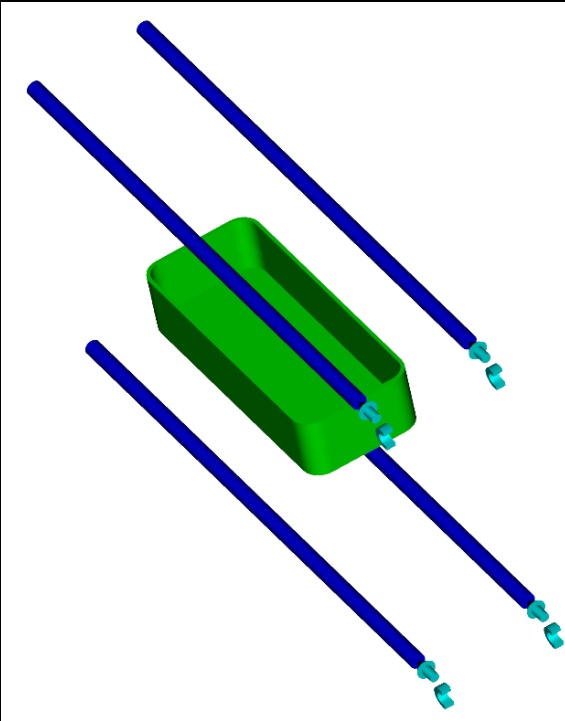

Cool Optimization for 3D printed Cores

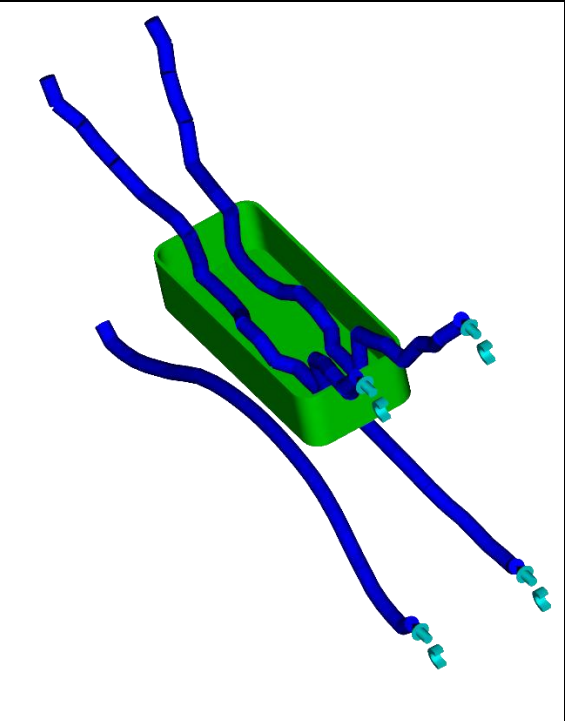

Cool Optimization for Drill & Plug molds

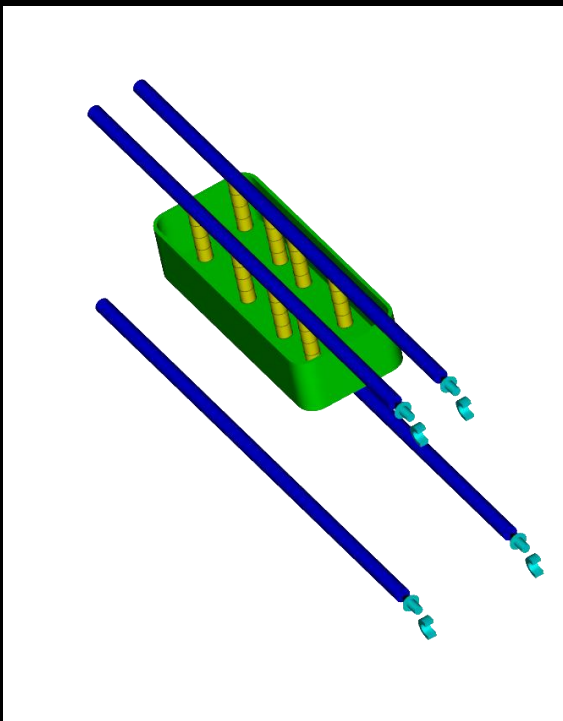

Moldflow 2027 | Cooling Optimization if for Drill and Plug molds

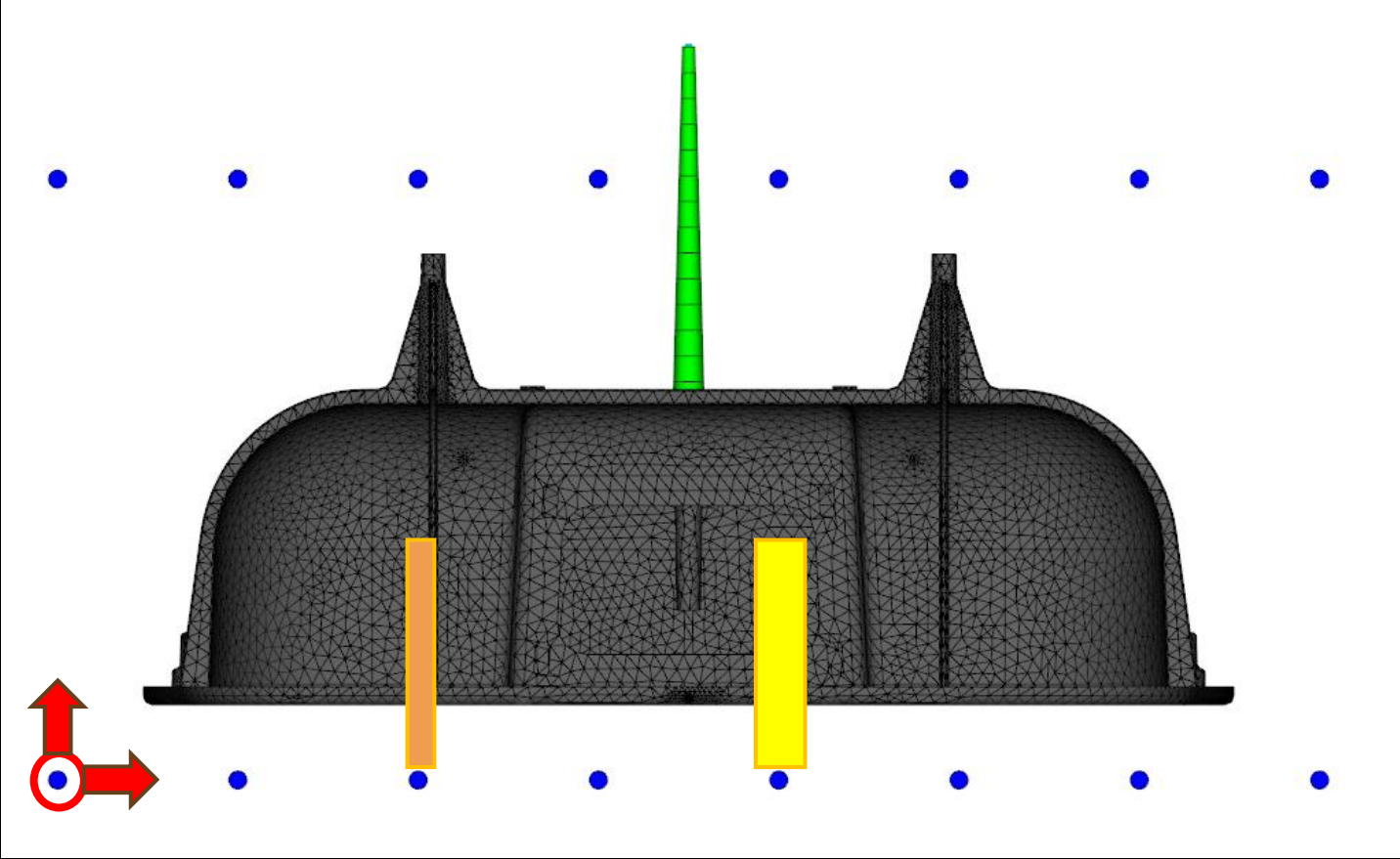

Bubblers

Baffles

Cooling channel optimization Objectives

Relative importance of Cycle Time	0.9	[0:1]
Relative importance of Warpage	0	[0:1]

Channel construction

Drill and plug	Baffle/bubbler options...
Drill and plug	
Additive	Advanced options...

Baffle/bubbler options

Drill and Plug style	Baffles or bubblers
Minimum distance between baffles or bubblers (as a ratio of channel diameter)	No baffles or bubblers
Transition from baffle to bubbler (as a ratio of channel diameter)	Baffles only
	Bubblers only
	Baffles or bubblers

Moldflow 2027 | Cooling Optimization if for Drill and Plug molds

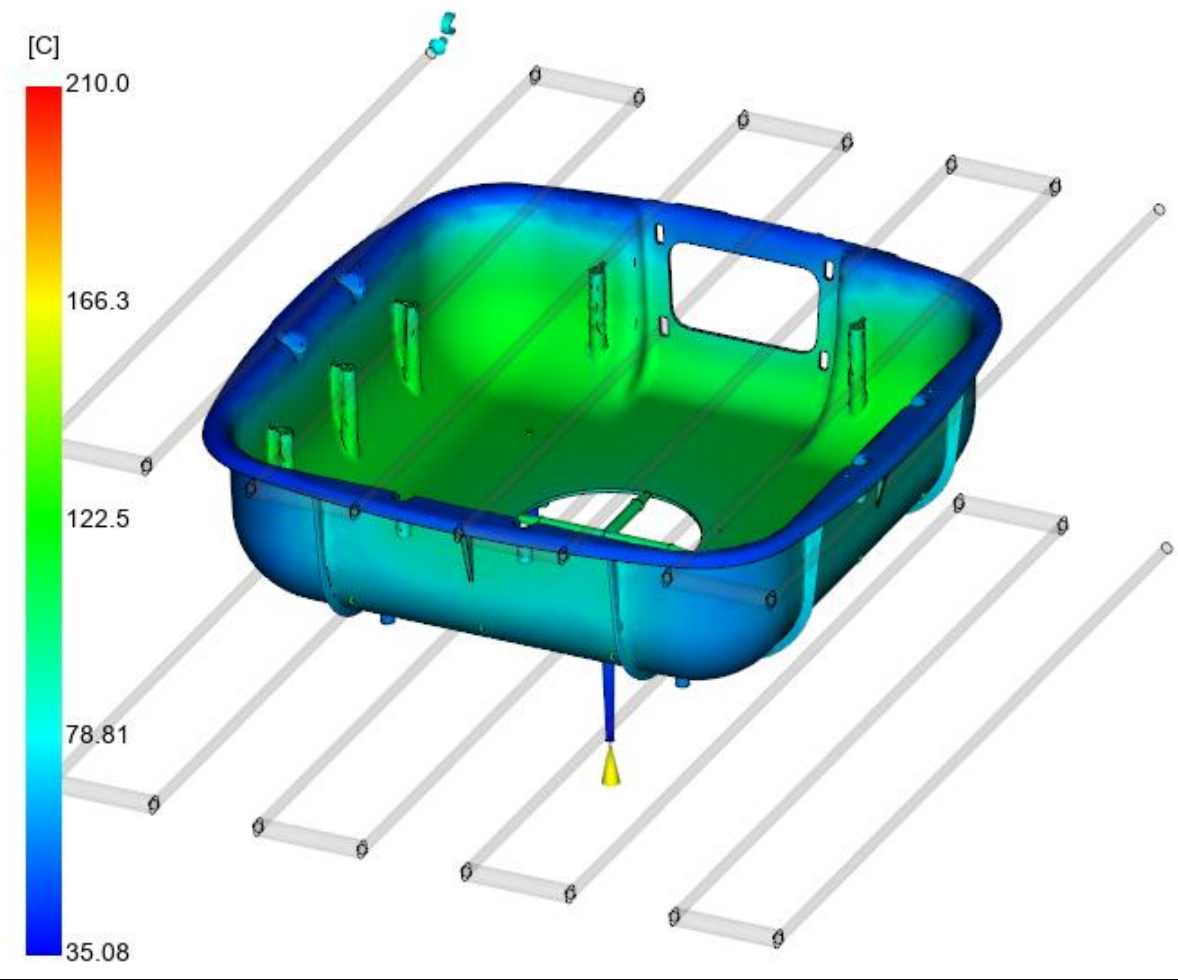
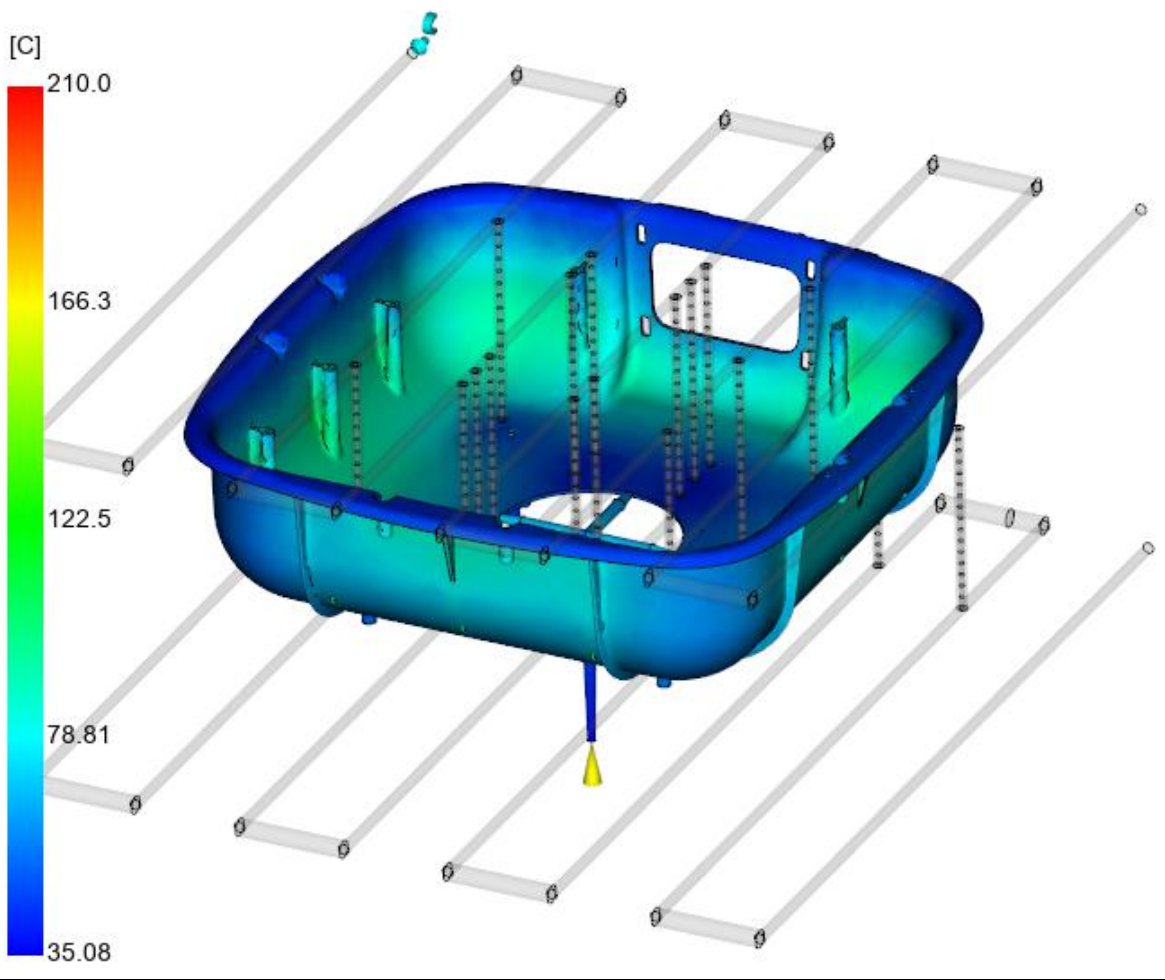

Moldflow 2027 | Various API updates

- New Python scripts can be run through a new command Window. Output and errors generated when running scripts are now displayed, making it easier to review results and diagnose issues.
- New API calls in the areas of:
 - CAD diagnostics
 - New Image and animation export options
- New StudyRlt improvements:
 - New –frame options
 - New –statistics options (e.g. –max, -Min, -Ave, -stddev, -count)
 - Support for XY Plot data
- Removal of obsolete API's

More information here:

<https://help.autodesk.com/view/MFIA/2027/ENU/?guid=MFLO-WHATS-NEW-2027-0-API> and
<https://help.autodesk.com/view/MFIA/2027/ENU/?guid=MFLO-WHATS-NEW-2027-0-FEATURES>

Moldflow 2027 | AiAssistant utility extracts summary data

- New command line utility to extract 'summary data' from the model and results.

```
Analysis commenced at      Sun Mar 15 14:32:51 2026

NAME:
  aiassistant - AI Assistant

SYNOPSIS:
C:\Program Files\Autodesk\Moldflow Synergy 2027\bin\aiassistant.exe -output filePrefix model_file
  [-all] [-model] [-material] [-machine] [-advice] [-results]
  [-mes RAW] [-units_option SI|ENGLISH|METRIC] [-help]

DESCRIPTION:
  model_file          model filename (with extension)
  -all                write all data [Default]
  -model              write model meta data
  -material            write material meta data
  -machine             write injection molding machine meta data
  -advice              write result advice meta data
  -results             write result meta data
  -key key            to specify a session key
  -kfile keyFile      to specify a session key filename (with extension)
  -output filePrefix  to specify an output file prefix
  -mes RAW            to specify a message mode
  -units_option SI|ENGLISH|METRIC to specify an units set
  -help               to print this help message.
```

Moldflow 2027 | Export of animated .gif is back

- In Moldflow 2026 we introduced the export of .mp4 animations and removed the export of animated .gif files. Due to popular demand with the 2027 release we re-introduce a ability to export .gif animations.
- The new .gif export includes new options for:
 - Controlling resolution
 - Animation speed.

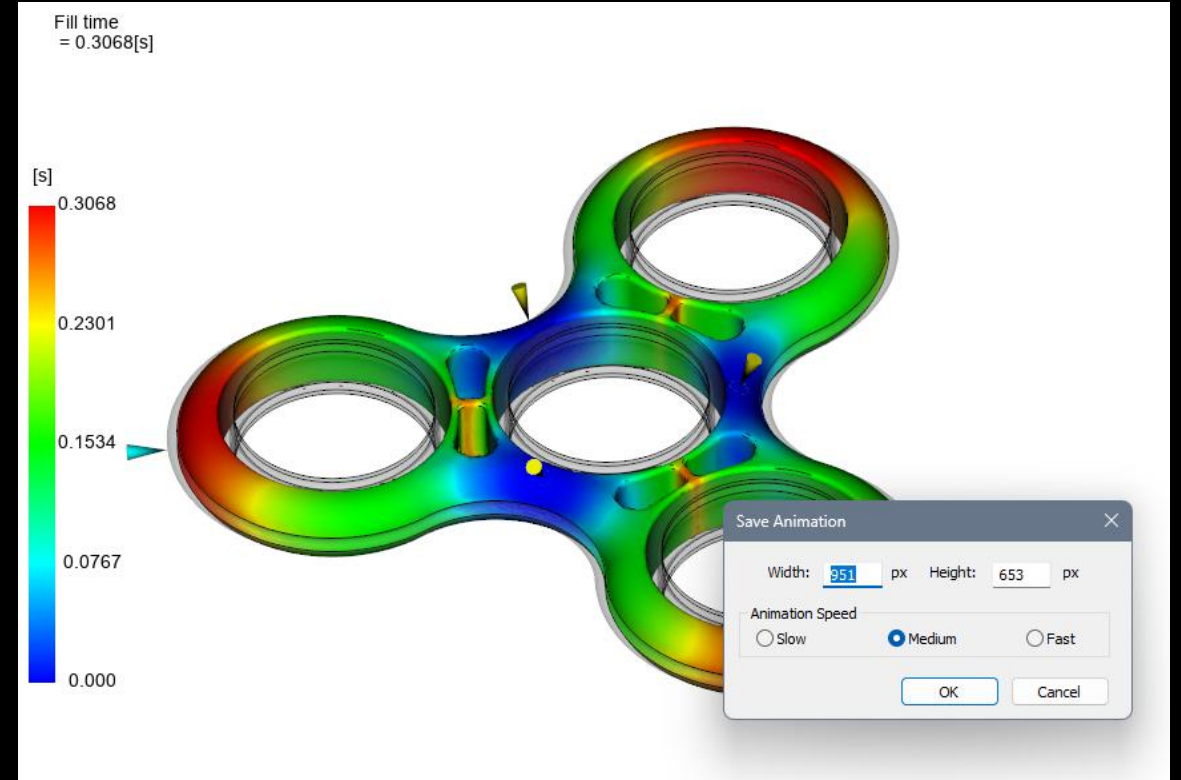

Moldflow 2027 | CAD translator updates

- Updated the CAD translators.
 - CATIA 6R2025
 - CATIA 6R2025 Assembly
 - Parasolid® V38
 - Creo™ Parametric 12
 - Autodesk Shape Manager 232
 - NX 2412, 2506 Series

Moldflow 2027 | Material database update

- New material database update.
 - 13871 thermoplastic materials from 634 material suppliers
 - 27 materials added since the last material database update
 - 434 materials changed
 - 2 materials deleted.
- Specifics:
 - Grades with Measured Shrinkage data: 6665
 - Grades with long-fiber length data: 303
 - Grades with specific Crystallization Morphology data: 45
 - Grades with Stress/Strain tension data: 2762



Moldflow 2027 | 3D corner effects (off by Default)

- Corner effect option is added to 3D Warp.
- This is off by default.

NOTE: Corner effects are not broken out separately in isolate cause of warpage

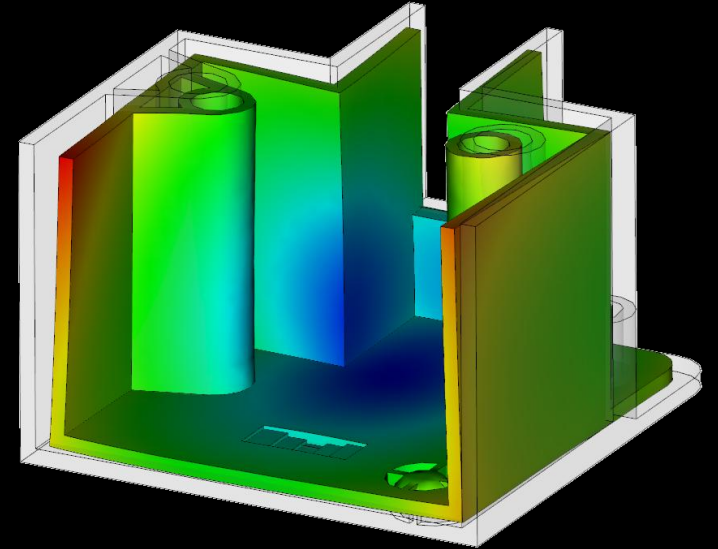

Process Settings Wizard - Warp Settings - Page 2 of 2

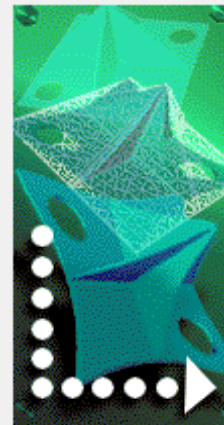

Warpage analysis type

Small deflection

Isolate cause of warpage

Upgrade tetrahedral elements to second order

All

Consider corner effects

Consider mold thermal expansion

Cavity dimensions include mold shrinkage allowance. Adjust constraint positions auto

Number of threads for parallelization

Automatic

Moldflow 2027 | 3D mesh refinement around the gate

New option to automatically refine the mesh around the gate.

Better mesh at the gate will improve predictions in the flow solver.

Works for with and without runner system.

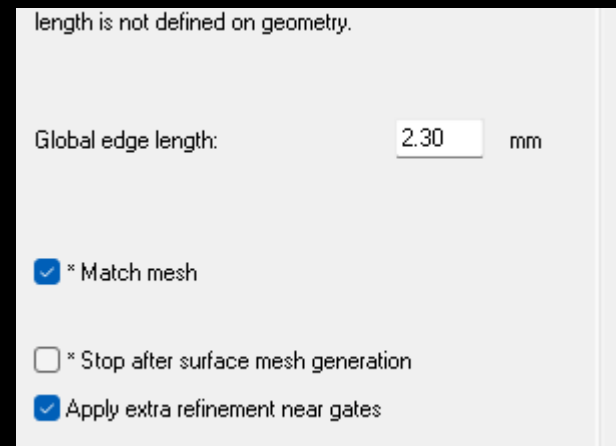
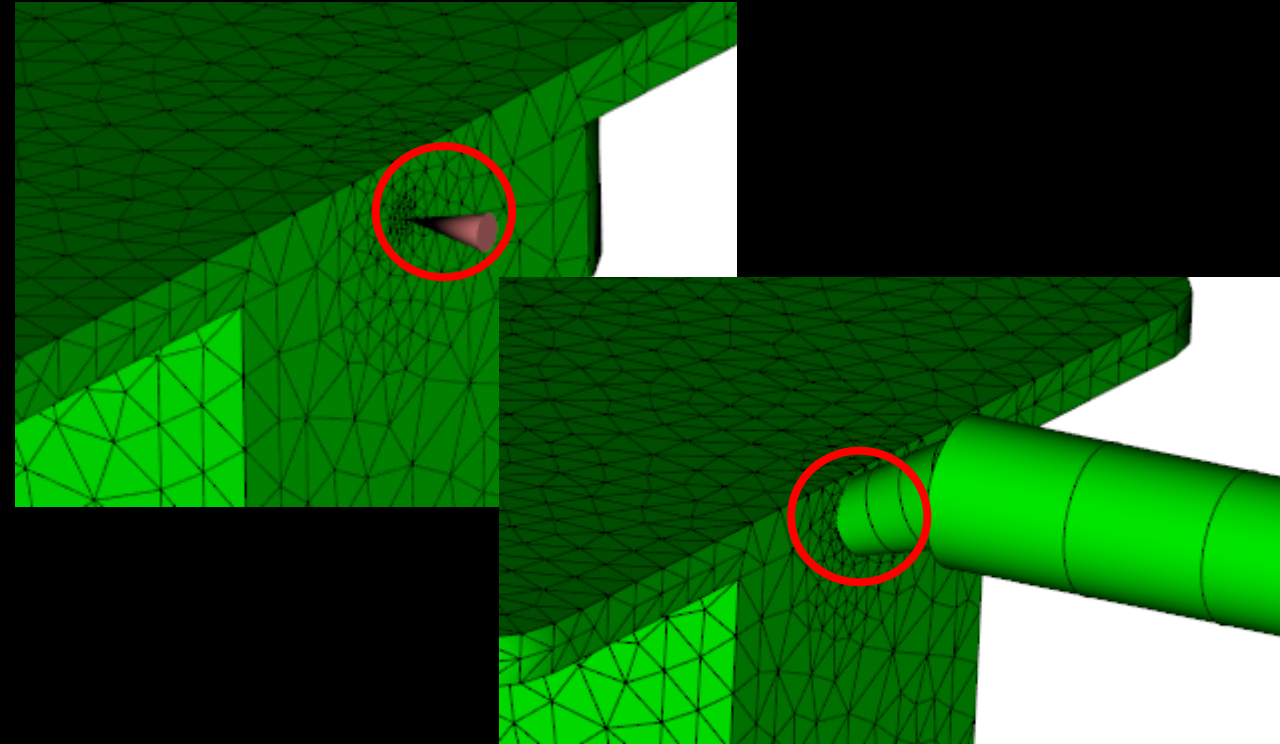

Moldflow 2027 | Improved residual Stress calculation for Midplane and Dual Domain

Improvement in residual stress calculation of Midplane and Dual Domain. The method brings this in line with 3D and improves consistency in warpage predictions between Midplane, Dual Domain and 3D.

The new method is Default with the old method being available as 'Legacy Uncorrected residual stress'

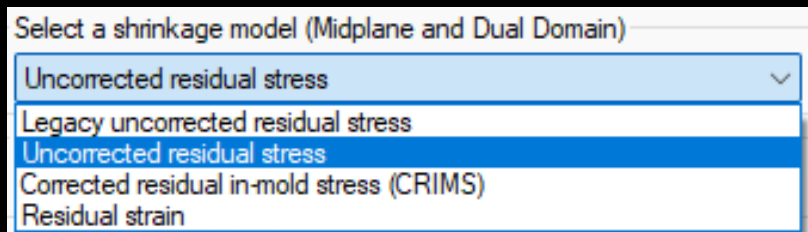

2026

DD Uncorr. Res. Stress

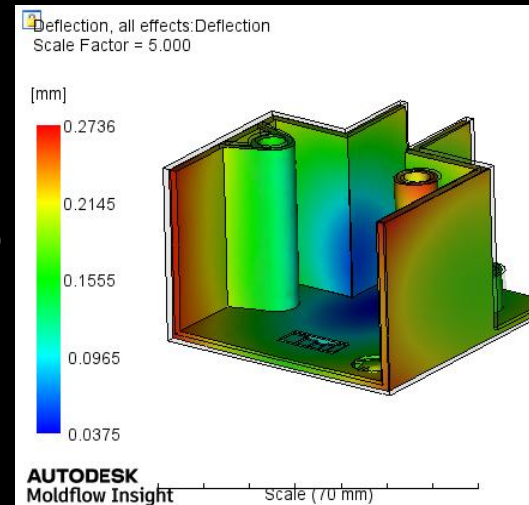

3D Uncorr. Res Stress

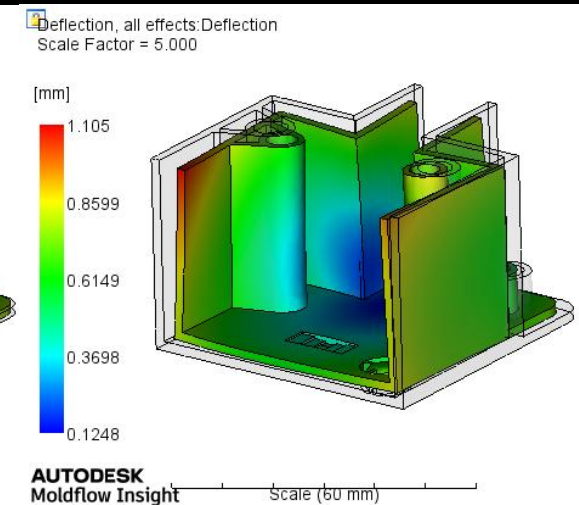

2027

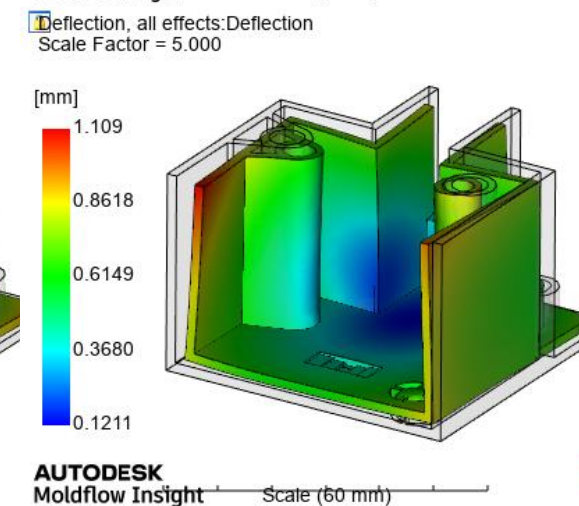
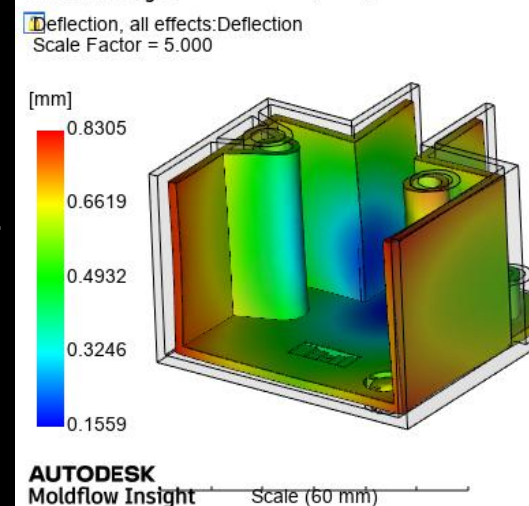

Moldflow 2027 | Improved residual Stress calculation for Midplane and Dual Domain

Improvement in residual stress calculation of Midplane and Dual Domain. The method brings this in line with 3D and improves consistency in warpage predictions between Midplane, Dual Domain and 3D.

The results do not meaningfully change CRIMS results, but the CRIMS coefficients will be different.

2026

DD Uncorr. Res. Stress

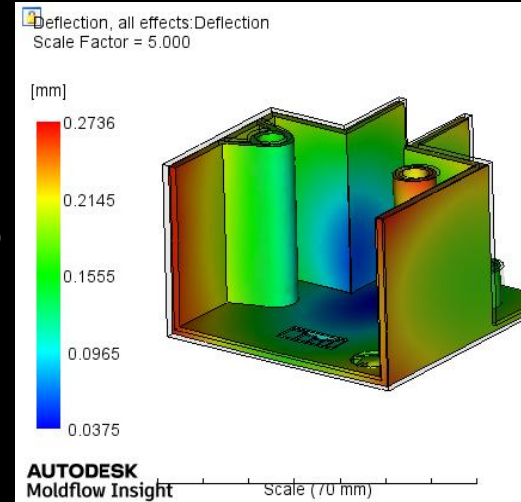

DD CRIMS

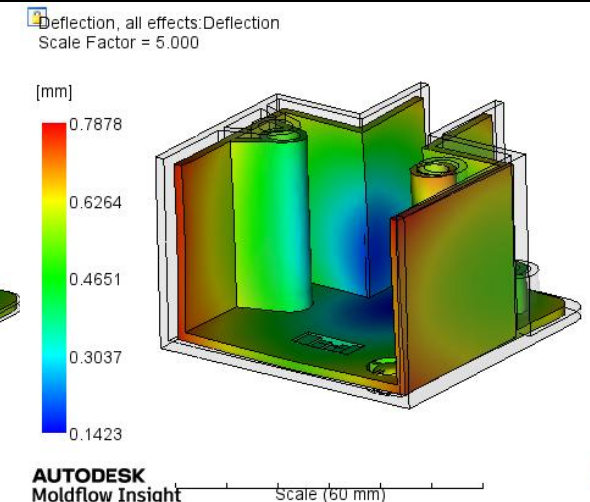

2027

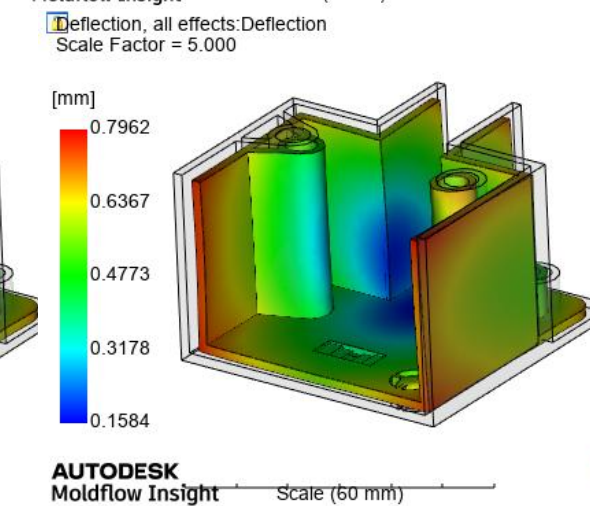
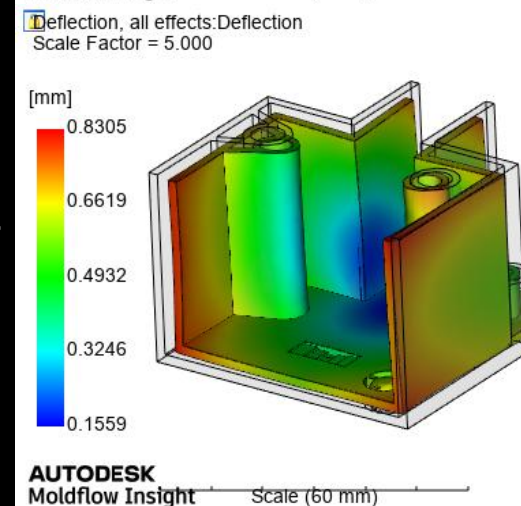

Moldflow 2027 | New Flow length result for 3D

- New Flow Length result for all 3D flow sequences

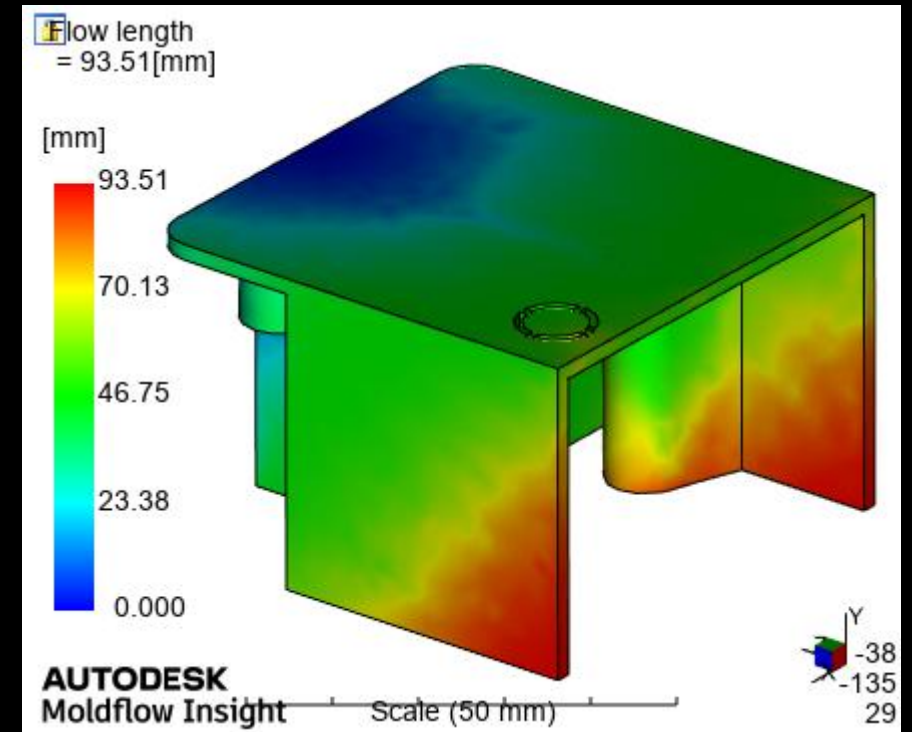

Moldflow 2027 | Herschel-Buckley cross WLF viscosity model for thermoplastic (MP/DD/3D)

- Support for new Herschel-Buckley cross WLF viscosity model for thermoplastics.
 - Supported in Midplane/Dual Domain and 3D
 - For materials that show increase in viscosity at low shear rates (e.g. Powder Inj. Molding materials)
 - Can help with simulation of 'plug flow'
 - No materials in the database yet or data fitting support

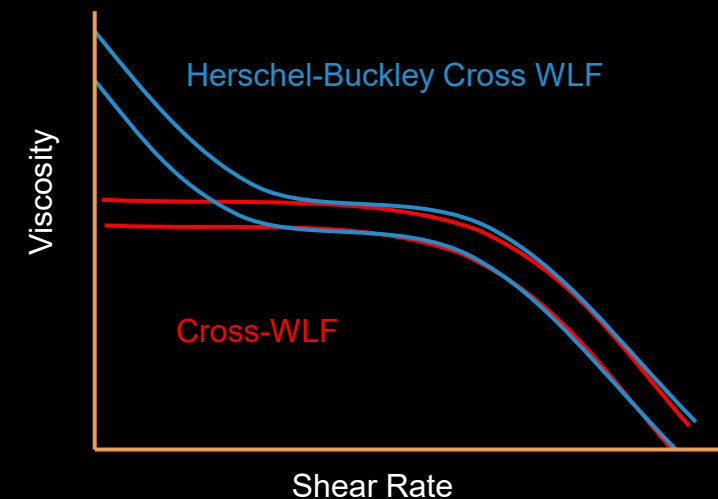
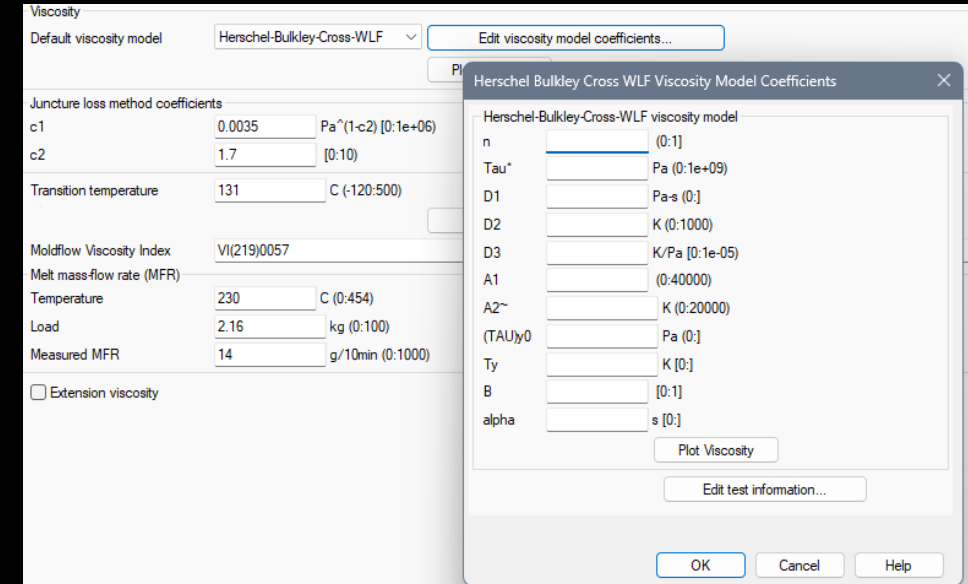

Moldflow 2027 | Various solver improvements:

Various solver improvements:

- Improved automatic constraints algorithm for warpage (all mesh types)
- Outer heater settings are now considered in the 3D Flow and Cool solver in Midplane and Dual Domain
- Cavity weight calculation in Midplane and Dual Domain is now made consistent with 3D and reports by cavity.
- Powder Injection molding is now available within thermoplastics:
 - Powder Properties can be added to thermoplastic material
 - Powder volume concentration result can be created.
- “Time to reach ejection temperature” for 3D flow is improved.

Moldflow 2027 | Autodesk Assistant for Moldflow

- A new Autodesk Assistant can help you with Moldflow:
 - Basic operation like opening projects, studies and results
 - Summarizing of the most important results in the analysis
 - Ask what results show problems you may want to be aware of
 - Ask for advice:
 - How to solve certain problems
 - How to model things like bubblers
 - Where do I collect SCM logs
- The Autodesk Assistant is currently in Tech Preview and requires you to accept the terms and conditions for use.

Note: we are collecting analytics data on prompts to understand success, understand how people use it, success rates etc. to help improve the quality of this service.

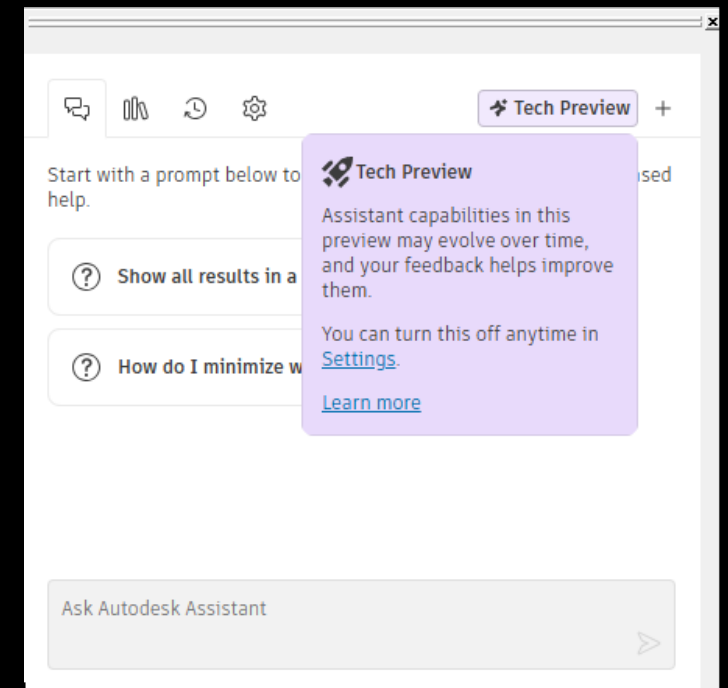
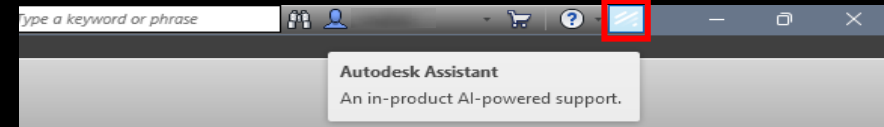

Moldflow 2027 | Autodesk Assistant for Moldflow (Cont.)

- A Chat with Autodesk Assistant is an ongoing conversation. You can use it to do collaborate on interpreting an analysis, and have it provide you with suggestions how to proceed.
- You can use your own language, and it will respond back in that language, even if Moldflow is not available in that language.
- You can use pre-configured starter prompts or it may provide you with a prompt of what it guesses you may be interested in doing next.
- You can save your favorite prompts.

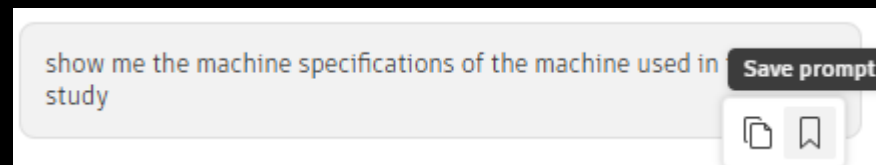

Prompts

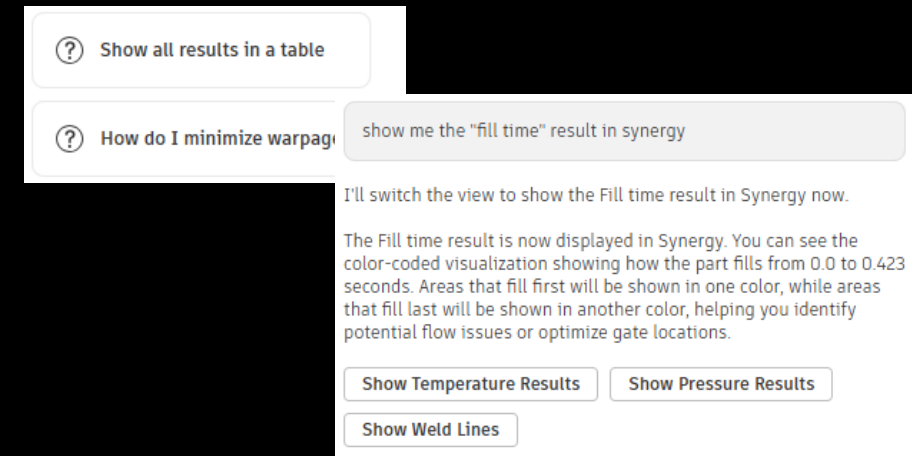

Local Language (e.g. German)

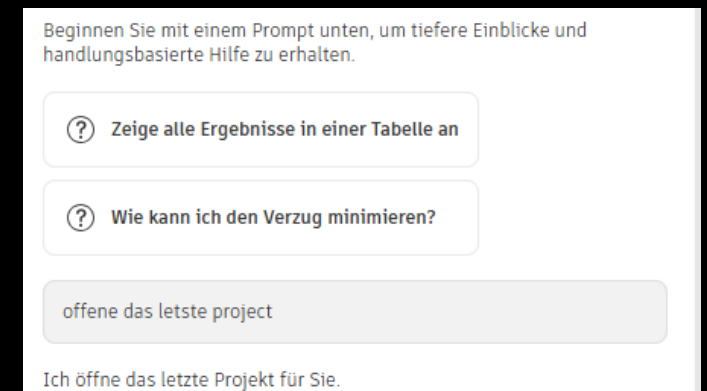

Moldflow 2027 | Autodesk Assistant for Moldflow (Cont.).

- Some powerful prompts you can use:

show a summary of the analysis results in a table

Results from study strip_study:

Result Name	Minimum	Maximum	Average	Unit
Fill time	0.000	0.798	-	s
Temperature	59.1	228.1	-	°C
Temperature at flow front	204.1	220.0	215.1	°C
Bulk temperature	50.2	227.2	-	°C
Bulk temperature at end...	181.5	227.2	205.7	°C
Pressure	0.0	66.6	-	MPa
Pressure at injection loc...	-	66.6	-	MPa

1-10 of 33

Show less

look at my results and help me identify what problems I may need to look at

Based on your analysis results for 'strip_study', here are the key issues to address:

- **Critical Issues**
 - **Very High Shear Rate:** Maximum shear rate of **37,031 s⁻¹** (bulk: 25,128 s⁻¹)
Risk: Material degradation, polymer chain breakage, poor mechanical properties
Recommendation: Reduce injection speed, increase gate size, or modify part thickness
 - **Air Traps Detected:** **5 air traps** present
Risk: Surface defects, incomplete filling, burn marks, weak weld lines
Recommendation: Add venting at trap locations, adjust fill pattern, or modify gate location
- ▲ **Moderate Concerns**
 - **High Injection Pressure:** Peak pressure of **66.6 MPa**
Risk: High clamping force requirement (25.8 tonnes), potential flash, increased cycle time
Recommendation: Optimize gate location, increase melt/mold temperature, or review part design
 - **Part Warpage:** Maximum deflection of **0.531 mm**
Risk: Dimensional accuracy issues, assembly problems
Recommendation: Review cooling system uniformity, optimize packing profile, check material shrinkage
 - **Frozen Layer at End of Fill:** Up to **32%** frozen (average 17%)
Risk: Premature freezing may restrict packing, leading to sink marks or voids
Recommendation: Increase melt temperature, reduce fill time, or optimize cooling
- ✓ **Positive Observations**
 - **Temperature Control:** Flow front temperature maintained between 204-220°C (average 215°C) - Good consistency
 - **Fill Time:** 0.798 seconds - Reasonable for part size
 - **Volumetric Shrinkage at Ejection:** 2.4% average - Within acceptable range for most materials

Priority Actions:

1. **Immediate:** Address high shear rate by reducing injection speed or increasing gate size
2. **High Priority:** Add venting to eliminate air traps
3. **Medium Priority:** Optimize cooling to reduce warpage and improve cycle time

Moldflow 2027 | Autodesk Assistant for Moldflow (Cont.).

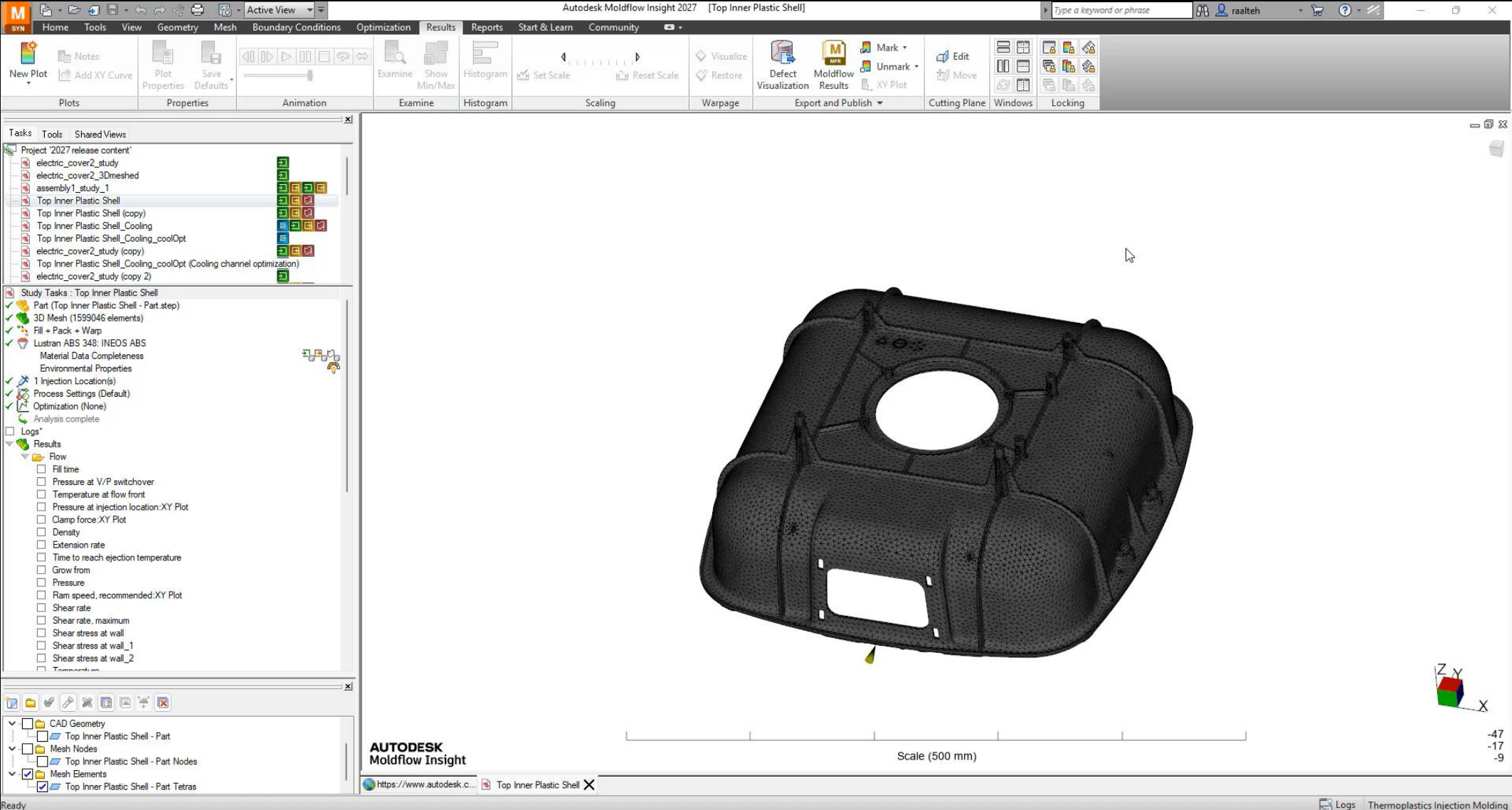

Moldflow 2027 | Autodesk Assistant for Moldflow (Cont.).

Autodesk assistant is available as a Technology preview and is a starting point:

- Though the knowledge base in Autodesk Assistant is good, the ability to have it do things in Moldflow are currently very basic. At this moment you cannot make setup or modeling changes.
- For long running tasks, do not change to a different study
- Autodesk Assistant cannot create scripts, reports or execute programs or access external sources.
- Not available in Moldflow Adviser.



Always check the results from the Autodesk Assistant. Autodesk Assistant can be very useful and powerful but can sometimes provide incorrect answers that sound plausible.



Moldflow 2027 Scandium

Update



Scandium Technology Preview

Free test version of Moldflow Insight that enables new capabilities in your commercial version of Moldflow Insight. This is available upon request through an application [here](#). Existing Scandium participants get access by logging into <https://feedback.autodesk.com/> and follow Project Scandium for Moldflow Insight. New applicants can apply here: <https://feedback.autodesk.com/welcome/key/F43KDMRN2HP6CGND>

These Moldflow Scandium specific capabilities require your feedback and input to help us get make these available in the commercial product.



Scandium Technology Preview

Autodesk Moldflow 2027 Scandium Technology Preview features:

- Enhanced Valve Gate Controls for Midplane, Dual Domain and 3D
- Cool FAME Solver for 3D Mold Cooling
- Partial mold restraint for insert over-molded, or 2 shot over-molded components
- Anisotropic Thermo-Viscoelastic Residual Stress Model
- Tiger Stripe Prediction
- Underflow diagnostic
- Fiber concentration
- Annealing analysis with viscoelastic material properties for Midplane and Dual-Domain meshes

Scandium Tech Preview | Mixed valve gate triggers (Midplane, Dual Domain and 3D)

Be able to open and close with different types of triggers for the Midplane, Dual Domain and 3D Flow solver

The solver part is available in the Technology preview. The User Interface implementation still needs further polishing.

- A new 'Mixed Trigger Valve Gate Controller' is added
- The old valve gates will continue to work but have been renamed to Legacy Valve Gate Controller

Velocity controlled valve gates are supported in both the Legacy Valve Gate Controller and the new Mixed Trigger Valve Gate Controller.

Mixed Trigger Valve Gates can be assigned on both beam and tetrahedral hot gate elements

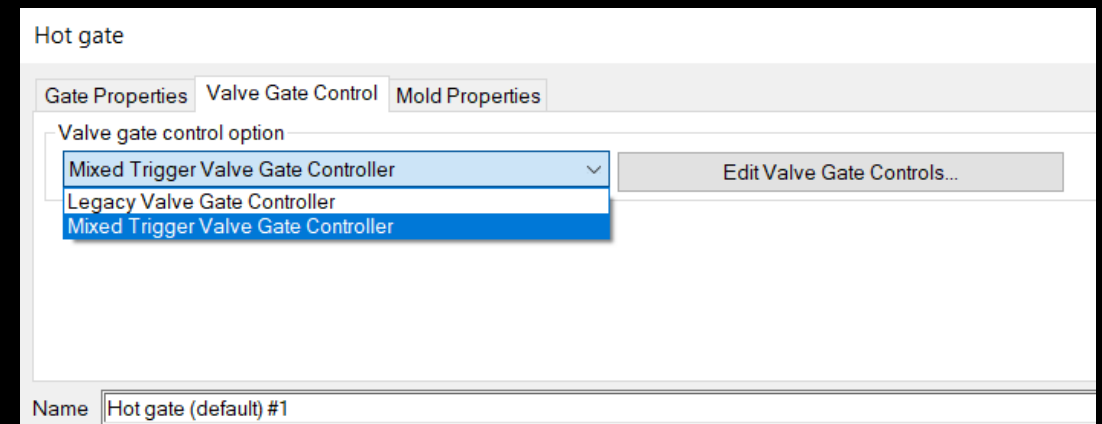

Scandium Tech Preview | Mixed valve gate triggers (Midplane, Dual Domain and 3D)

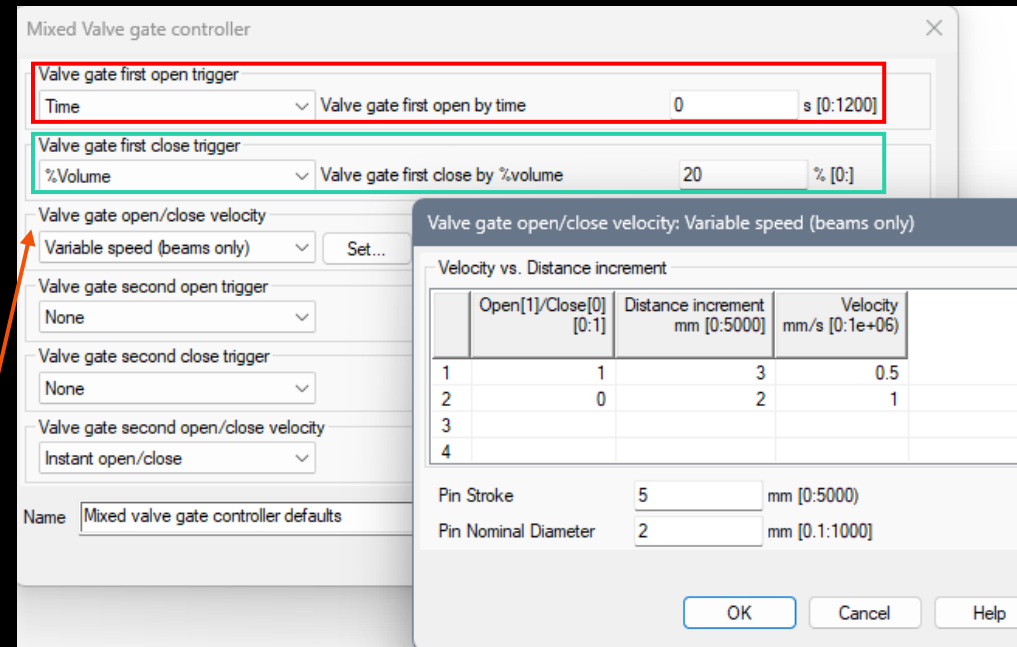
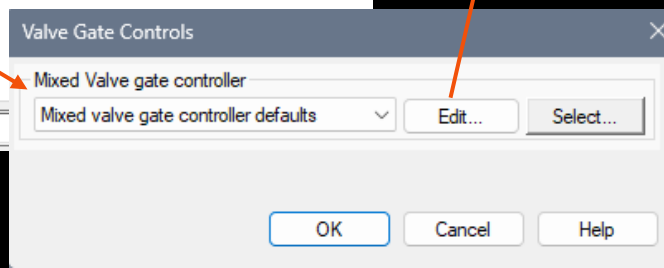
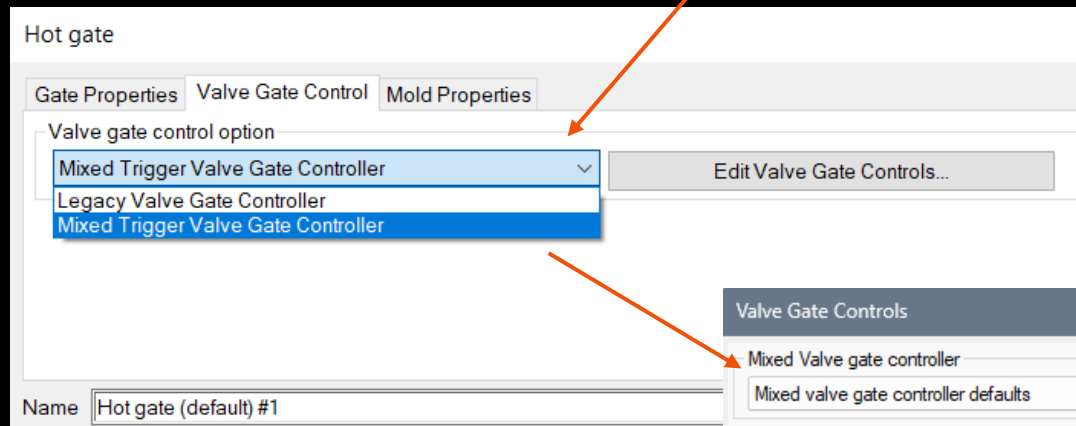
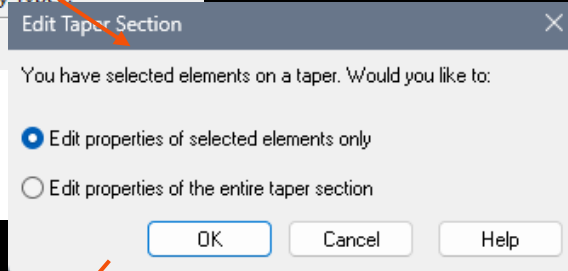
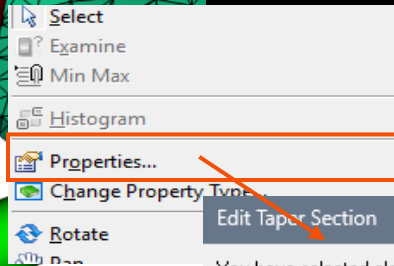
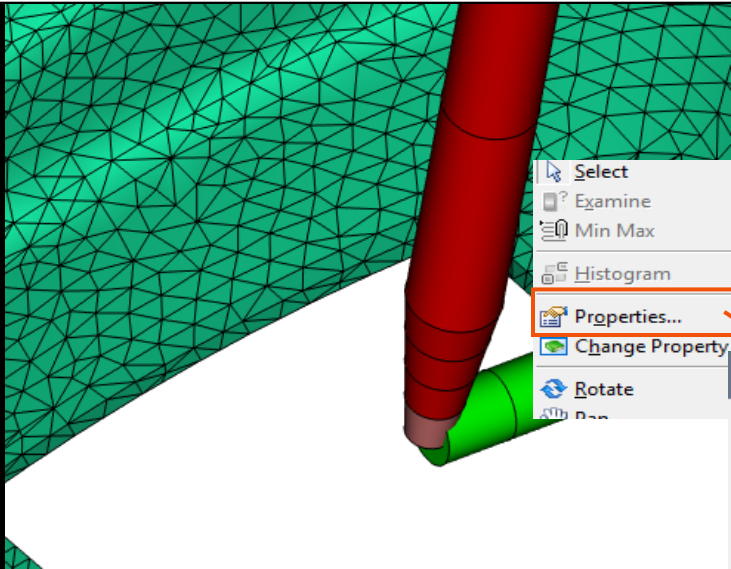

Valve gate open/close velocity: Variable speed (beams only)

Velocity vs. Distance increment

	Open[1]/Close[0] [0:1]	Distance increment mm [0:5000]	Velocity mm/s [0.1e+06]
1	1	3	0.5
2	0	2	1
3			
4			

Pin Stroke 5 mm [0:5000]
Pin Nominal Diameter 2 mm [0.1:1000]

OK Cancel Help

Scandium Tech Preview | New Valve Gate trigger option

For Mixed trigger for valve gates, two new options are available:

- New 'Open' trigger
 - 'End of Filling'
- Close trigger
 - 'End of Filling'
 - 'End of packing'

The 'end of packing' also works with the 'Automatic Packing' Option

Velocity Controlled valves on beams gates are also supported for 3D.

Note:

- the triggers define when the valve opens/closes.
- The velocity table defines the speed at which the opening and closing happens.

Mixed Valve gate controller

Valve gate first open trigger
End of Filling

Valve gate first close trigger
None
None
Time
Flow front
Pressure
%Volume
Ram position
End of Filling
End of packing

Valve gate second close trigger
None

Valve gate second open/close velocity
Instant open/close

Name Mixed valve gate controller defaults

Moldflow Scandium 2027 | Cool FAME

New Cool FAME solver:

- From the ground up new developed Cooling solver for 3D. This solver is typically faster than the Cool (BEM) and Cool (FEM) solver, particularly for large models, and does not require the generation of FEM Mold mesh. It combines the ease of modelling of Cool BEM with the speed of Cool FEM.
- Currently limited to steady state analysis, 3D and thermoplastic injection molding.
- Supported element types:
 - Part (3D)
 - Mold block (3D)
 - Mold surface
 - Beam cooling channels,
 - Beam hot runners,
 - Beam cold runners.
- Important currently not supported:
 - 3D runners, Inserts and Midplane and Dual Domain.

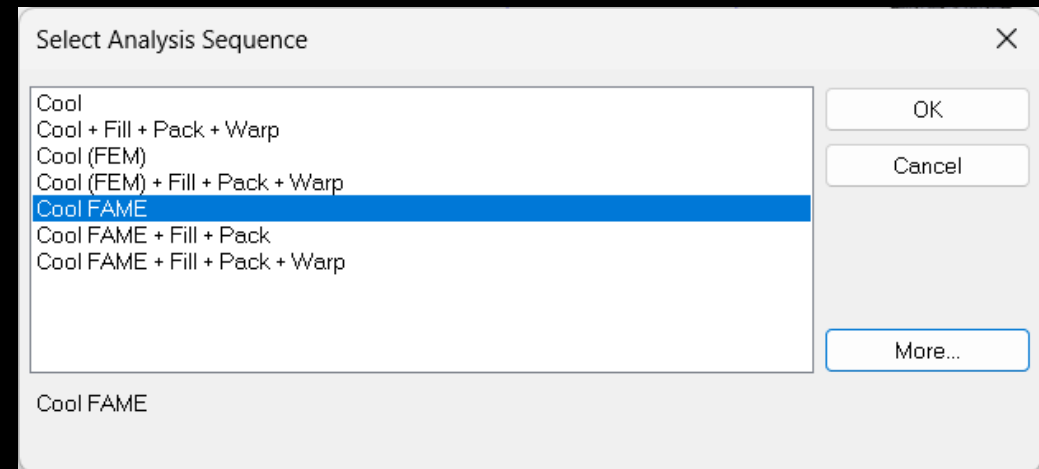

Moldflow Scandium 2027 | Cool FAME

Cool BEM

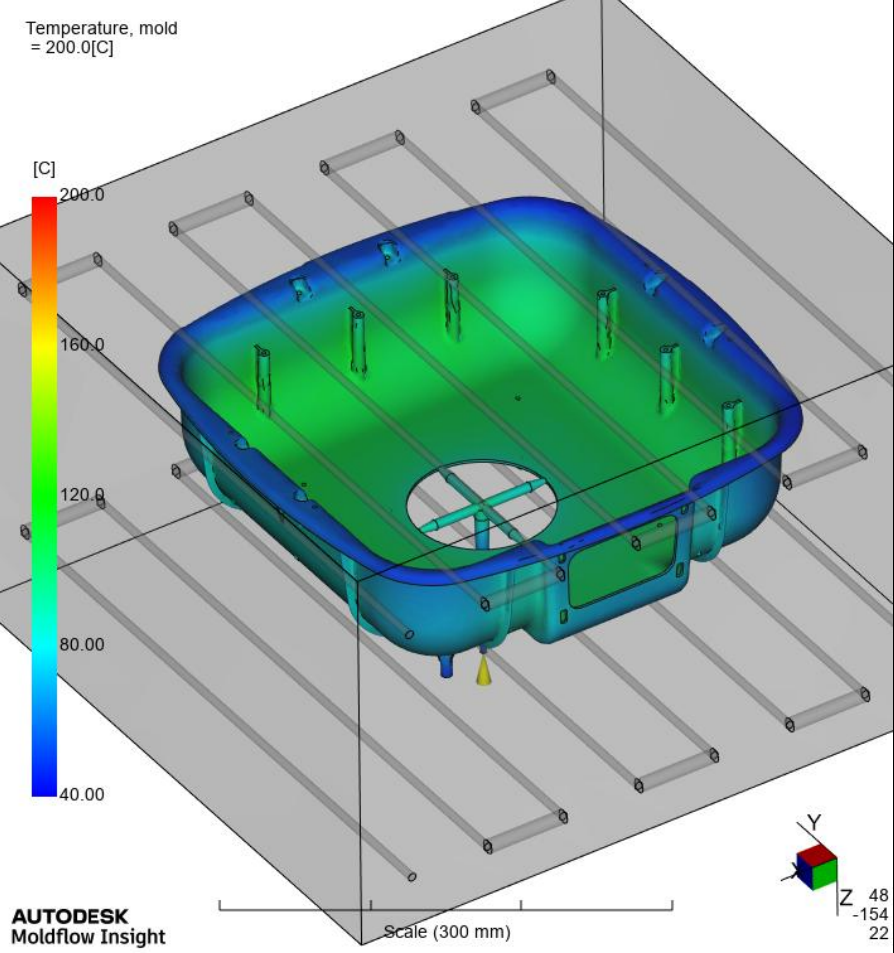

1 hour 32 Minutes

Cool FAME

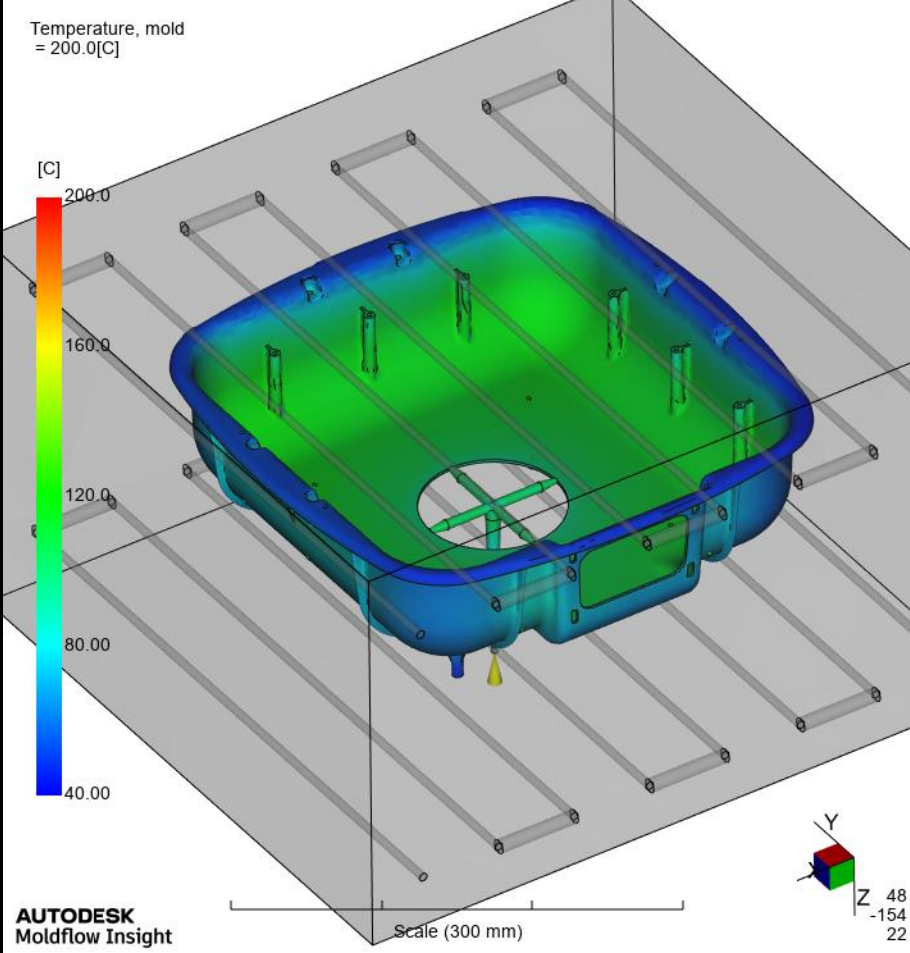

39 Minutes

Scandium Tech Preview | Improved 3D Insert Overmolding warp

New 3D Insert Overmolding and 2 shot overmolding improvement accounts better for thermal stress build up in an insert.

Old Scheme

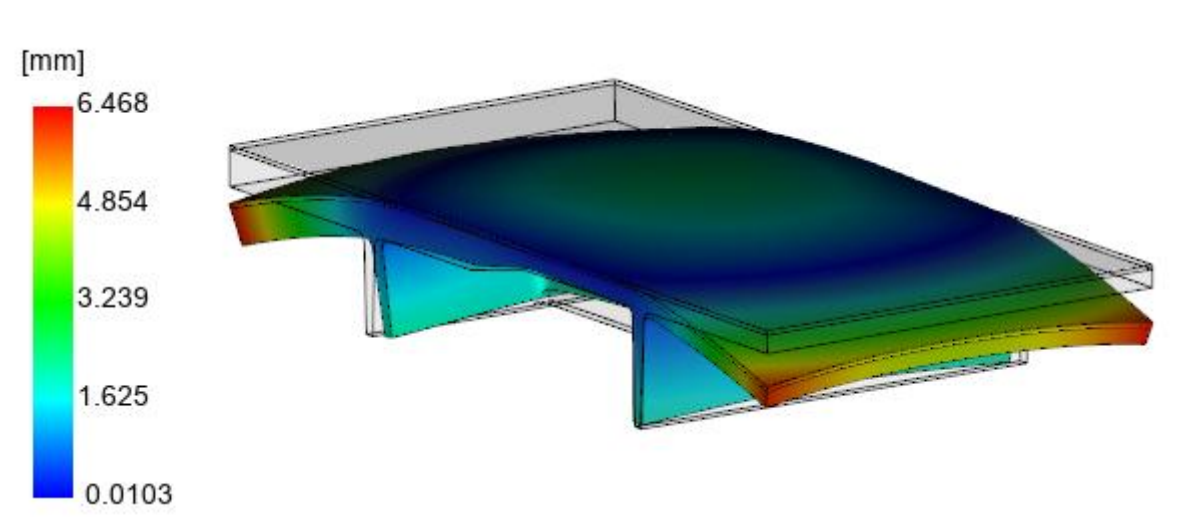

New Partial Mold Constraint

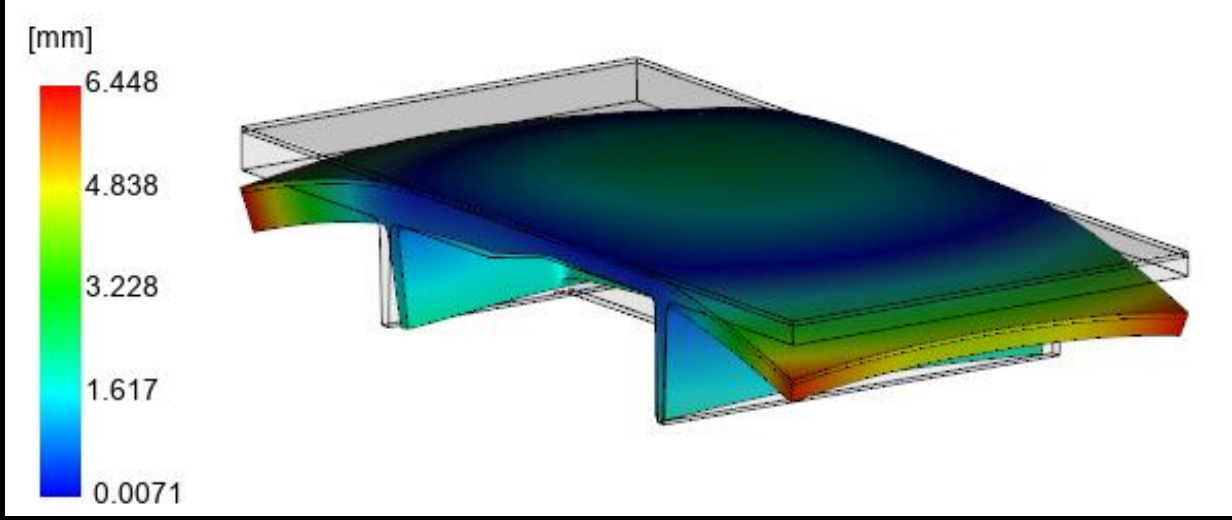

Scandium Tech Preview | Improved 3D Insert Overmolding warp

New 3D Insert Overmolding and 2 shot overmolding improvement accounts better for thermal stress build up in an insert.

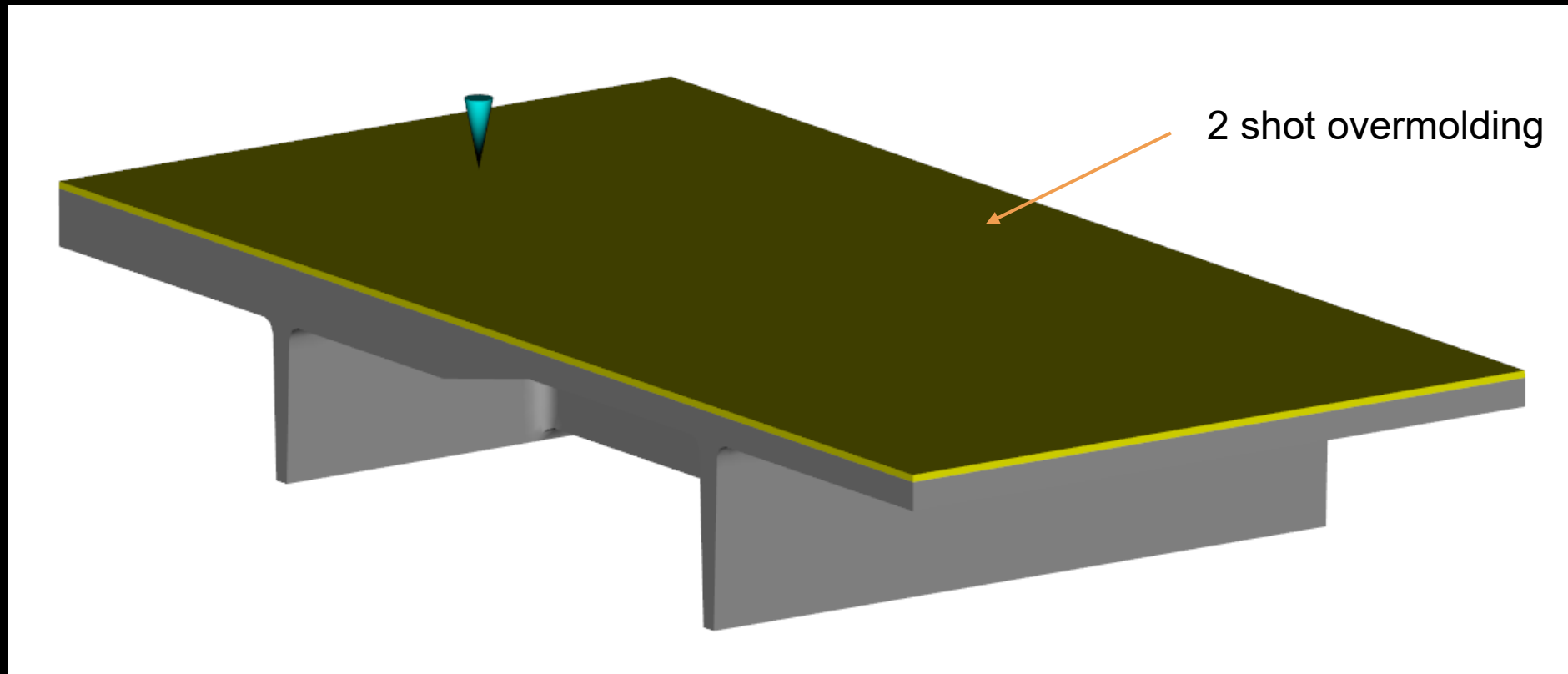

Scandium Tech Preview | Improved 3D Insert Overmolding warp

New 3D Insert Overmolding and 2 shot overmolding improvement accounts better for thermal stress build up in an insert.

Old Scheme

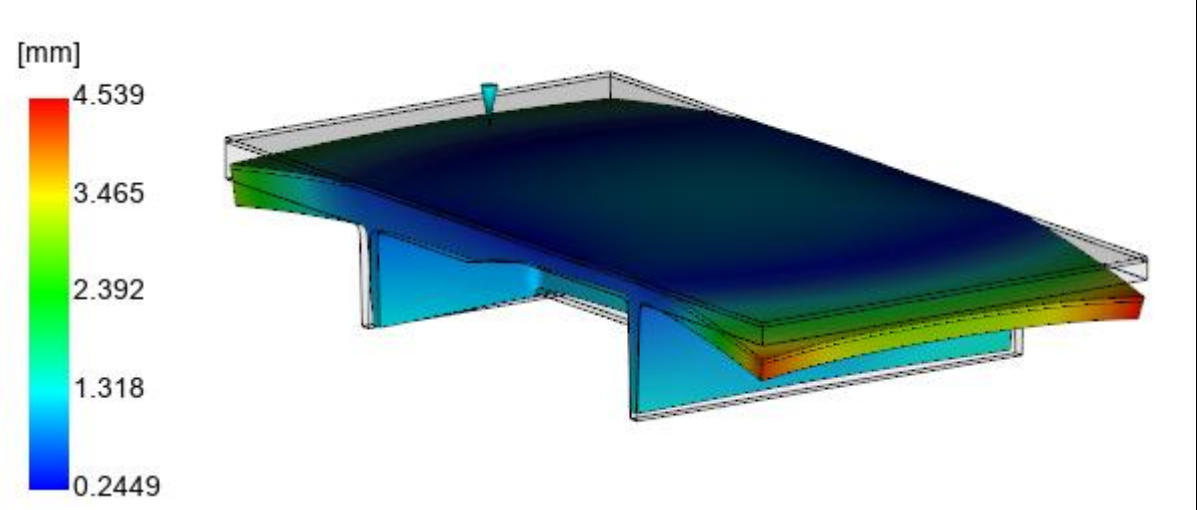

New Partial Mold Constraint

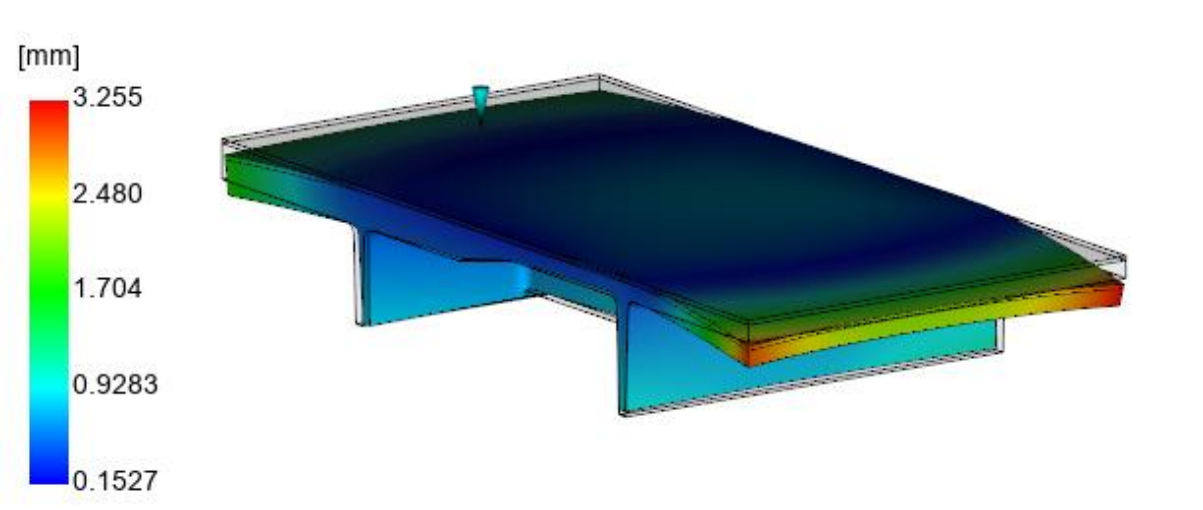

Final Thoughts



Final thoughts

The Moldflow 2027 is a foundational release with:

- Targeted improvements in the Moldflow solvers
- Focus on customer driven enhancements
- Modernize the foundations of the Moldflow products
- First introduction of the Agentic AI in Moldflow





Autodesk and the Autodesk logo are registered trademarks or trademarks of Autodesk, Inc., and/or its subsidiaries and/or affiliates in the USA and/or other countries. All other brand names, product names, or trademarks belong to their respective holders. Autodesk reserves the right to alter product and services offerings, and specifications and pricing at any time without notice, and is not responsible for typographical or graphical errors that may appear in this document. © 2026 Autodesk. All rights reserved.