

# Accurate, Optimized Design

## Runner Balancing Module in Autodesk Simulation Moldflow helps locate and resolve multi cavity mold issue.

“We provide moldflow analysis support right from validating part design, guiding mold design and resolving part manufacturing issues. So, the challenges we face are always different and Autodesk Simulation Moldflow helps us to address them”.

- **Krishnamoorthy**  
Director, Rheomold

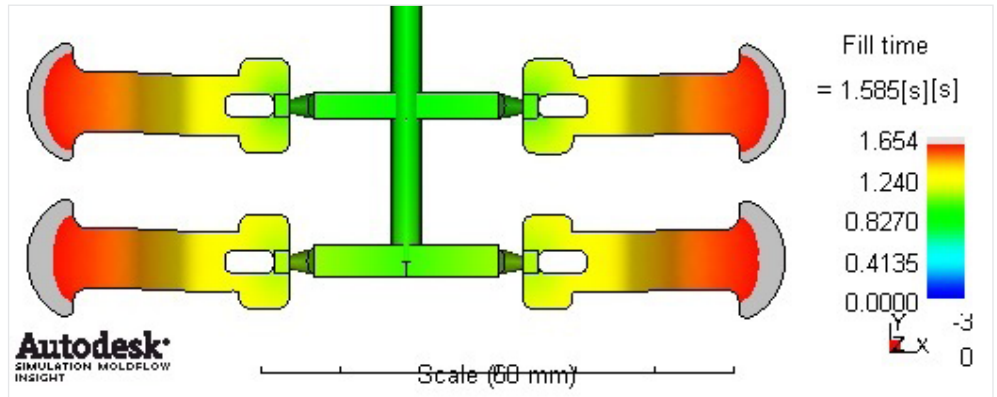

Image courtesy of Rheomold

Founded in 2011, Rheomold provides analysis services for injection moulded plastic parts. Located in Pune, the capital of automotive manufacturers in India. Rheomold offers Autodesk Moldflow services to validate customers' product, mould design, and their moulding process. They provide specialized solutions for automotive applications like interiors, exterior and power train plastic parts.

Mr. Krishnamoorthy the founder of Rheomold has spent more than 12 years in mold design and simulation, and his vast experience has helped them to address the customer requirements. “We provide moldflow analysis support right from validating part design, guiding mold design and resolving part manufacturing issues. So, the challenges we face are always different and

Autodesk® Simulation Moldflow® helps us to address them” said Mr. Krishnamoorthy

### Challenges:

One of the leading automotive supplier approached Rheomold to resolve their multi cavity mould issue, which they could not solve using traditional methods and their experience.

The customer was facing a challenging situation in developing plastic buttons for automotive application using 32 cavity mould. When the material (PA66) was passed through the machine nozzle the first 16 cavities used to feed faster than the other 16 cavities. Up to 5% imbalance was registered in the cavities because of which flow was unbalanced and the part over packing resulted in flashes. This condition led to 50%

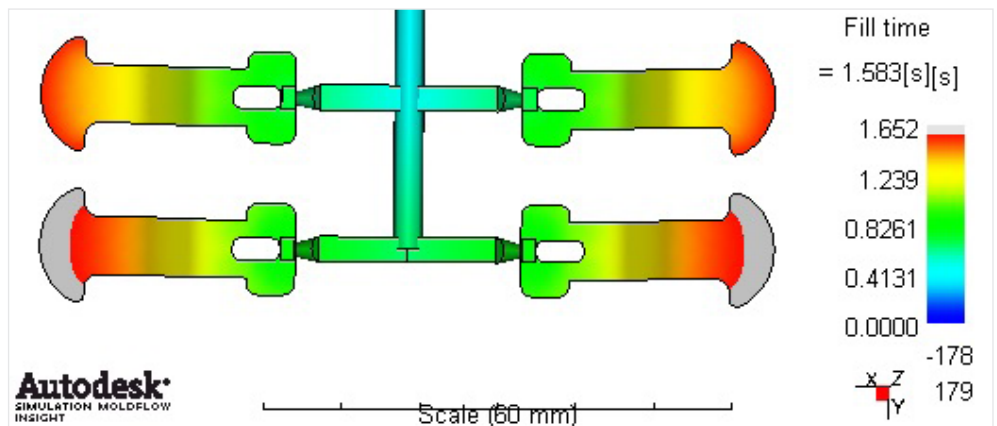

Image courtesy of Rheomold

rejection in the parts produced ie. 16 out of 32 parts were rejected due to flashes.

Rheomold's customer was looking for an artificially balanced runner system with no changes in the process. The engineers at Rheomold did micro level process capturing, analyzed all details of the feed lines. Using "Runner Balancing module" in Autodesk Simulation Moldflow plastic insight, resized the sub runners of every second pair in the multi cavity mould. After comparing and checking the simulation results from Autodesk Simulation Moldflow they recommended the client to increase the sub runner size by 15% from 3.33mm to 4.17mm to overcome the part over packing.

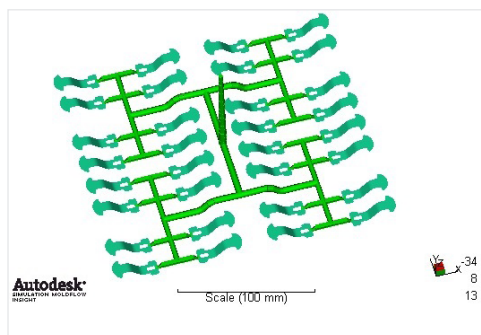

Image courtesy of Rheomold

#### Results:

"Autodesk Simulation Moldflow effectively eliminates the use of trial and error method by validating and optimizing the design of plastic before production. This not only improves the quality but also help us to guide our customers about the selection of machines and the production planning" said Mr. Krishnamoorthy

After optimizing the sub runner size using Autodesk Simulation Moldflow and comparing the simulation results with the existing mold they checked the part for repeatability in production to ensure uniform flow of material to all 32 cavities without flashes. Rheomold was able to reduce the flashes from 50% to 0% and helped their client save over 8 lakhs Per Annum in production costs.

#### Key Benefits:

It was the 12 years expertise using Autodesk Simulation Moldflow that inspired the Rheomold founder to start the plastic injection molding simulation services. One of the big advantages of Autodesk Simulation Moldflow is that its functionality is easy to use and it validates and optimizes the design of plastic parts and injection moulds by predicting the plastic injection moulding process with very high accuracy.

"One of the most important results of using Autodesk Simulation Moldflow has been able to win more business by providing more accurate, optimized final results with fewer iterations " explains Mr. Krishnamoorthy.

"Autodesk Simulation Moldflow effectively eliminates the use of trial and error method by validating and optimizing the design of plastic before production. This not only improves the quality but also help us to guide our customers in the selection of machines and in production planning"

**-Krishnamoorthy**

Director, Rheomold